

REQUEST FOR PROPOSAL (RFP)

FOR GOODS

Project Title:	EU FSM Sustainable Energy (EU FSM.SE) Project
Nature of the goods	Supply and delivery of a 60kWp solar PV grid connected system with battery energy storage system to Yap, Federated States of Micronesia
Location:	Yap, FSM
Date of issue:	17/06/2022
Closing Date:	22/07/2022
SPC Reference:	RFP22-3712

Contents

PART 1: INTRODUCTION	3
1.1 ABOUT THE PACIFIC COMMUNITY (SPC)	3
1.2 SPC'S PROCUREMENT ACTIVITIES	3
1.3 SPC'S REQUEST FOR PROPOSAL (RFP) PROCESS	3
PART 2: INSTRUCTIONS TO BIDDERS	4
2.1 BACKGROUND	4
2.2 SUBMISSION INSTRUCTIONS	4
2.3 CLARIFICATIONS	4
2.4 EVALUATION	5
2.5 CONTRACT AWARD	5
2.6 KEY DATES	6
2.7 LEGAL AND COMPLIANCE	6
2.8 COMPLAINTS PROCESS	7
PART 3: SPECIFICATION OF GOODS	8
PROJECT TITLE: EU FSM SUSTAINABLE ENERGY (EU FSM.SE) PROJECT.	8
C. INSTITUTIONAL ARRANGEMENT	10
D. EVALUATION CRITERIA	10
PART 4: PROPOSAL EVALUATION MATRIX	39
4.1 COMPETENCY REQUIREMENTS & SCORE WEIGHT	39
4.2 FINANCIAL EVALUATION	40
PART 5: PROPOSAL SUBMISSION FORMS	41
ANNEX 1: BIDDER'S LETTER OF APPLICATION	41
ANNEX 2: CONFLICT OF INTEREST DECLARATION	42
What is a conflict of interest?	42
Always declare a conflict	42
Declaration at any time	42
Declaration for any person involved	42
Failure	42
ANNEX 3: INFORMATION ABOUT THE BIDDER AND DUE DILIGENCE	44
VENDOR INFORMATION	44
DUE DILIGENCE	44
SOCIAL AND ENVIRONMENTAL RESPONSIBILITY (SER)	45
ANNEX 4: TECHNICAL PROPOSAL SUBMISSION FORM	47
INSTRUCTIONS TO BIDDERS	47
ANNEX 5: FINANCIAL PROPOSAL SUBMISSION FORM	55

Part 1: INTRODUCTION

1.1 About the Pacific Community (SPC)

The Pacific Community (SPC) is the principal scientific and technical organisation of the Pacific region, established by treaty in 1947 with the signing of the Agreement Establishing the South Pacific Commission (the Canberra Agreement).

SPC has our headquarters in Noumea, New Caledonia and has regional offices in Fiji, the Federated States of Micronesia and Vanuatu, as well as an office in France. SPC works across the Pacific and has staff in nearly all of our Pacific Island Country and Territory members.

SPC works for the well-being of Pacific people through the effective and innovative application of science and knowledge and is guided by a deep understanding of Pacific Island contexts and cultures. Our unique organisation covers more than 20 sectors and is renowned for knowledge and innovation in such areas as fisheries science, public health surveillance, geoscience and conservation of plant genetic resources for food security.

For more information about SPC and the work that we do, please visit our website: <https://www.spc.int/>.

1.2 SPC's procurement activities

SPC's procurement activities are guided by the principles of high ethical standards, value for money, open competition and social and environmental responsibility and are carried out under our Procurement Policy.

SPC's *Procurement Policy* provides the framework for ensuring that SPC obtains the best value for its purchases, in terms of both cost and quality; demonstrates financial probity and accountability to its members and development partners; manages and prevents the potential for conflicts of interest; reduces its environmental impact and manages any other risks.

At SPC, all procurement follows the same main steps: planning; statement of needs; requisition; solicitation; evaluation; award; receipt; and payment. Different procedures apply depending on the value of the goods, services and works to be procured.

For further information or enquiries about SPC's procurement activities, please visit the procurement pages on our website: <https://www.spc.int/procurement> or email: procurement@spc.int.

1.3 SPC's Request for Proposal (RFP) Process

At SPC, procurement valued at more than EUR 45,000 must be advertised through a Request for Proposal (RFP) with any bids received evaluated by SPC's Procurement Committee to determine the offer that provides the best value for money.

This RFP sets out SPC's requirements and it asks you, as a bidder, to respond in writing in a prescribed format with pricing and other required information. The RFP contains detailed instructions and templates to enable you to submit a compliant bid. It sets out the overall timetable; it confirms the evaluation criteria that SPC will use to evaluate quotations; it explains the administrative arrangements for the receipt of the bids; and it sets out how bidders can request further information.

Your participation confirms your acceptance of SPC's conditions of participation in the RFP process.

Part 2: INSTRUCTIONS TO BIDDERS

2.1 Background

SPC invites you to submit a bid to deliver the goods as specified in [Part 3](#).

SPC has advertised this RFP on its website and may send it directly to potential vendors. The same specifications, submission and other solicitation requirements will be provided to all vendors.

SPC has compiled these instructions to guide prospective bidders and to ensure that all bidders are given equal and fair consideration.

Please read the instructions carefully before submitting your bid. For your bid to be considered, you must provide all the prescribed information by the closing date and in the format specified.

2.2 Submission instructions

Your submission must be clear, concise and complete and should only include information that is necessary to respond effectively to this RFP. Please note that you may be marked down or excluded from the procurement exercise if your submission contains any ambiguities or lacks clarity.

Your proposal must include the following documents:

- (1) Bidder's Letter of Application (Annex 1);
- (2) Conflict of Interest Declaration (Annex 2);
- (3) Information about the bidder and Due diligence (Annex 3);
- (4) Technical proposal submission form (Annex4);
- (5) Financial proposal submission form (Annex 5).

Your proposal must be submitted in **two separate emails**.

You must submit your **Technical proposal** (Annexes 1 to 4 and all their supporting documents) in English as an attachment to one email. No financial information may appear in the technical proposal.

You must submit your **Financial proposal** (Annex 5) in a separate email. All prices in the proposal must be presented in USD. Your Financial proposal is to be password protected. SPC will request the password in the event that it is required.

Both emails are to be sent to procurement@spc.int with the subject line of your email as: **Submission RFP22-3712**.

Your proposal must be received no later than **22/07/2022** by **4.00PM Fiji Time**. Only one bid per bidder is permitted.

SPC will send a formal acknowledgement to each proposal received before the deadline.

SPC reserves the right to exclude from consideration any proposal not received by the deadline, with incomplete information or in incorrect form.

2.3 Clarifications

You may submit questions or seek clarifications on any issue relating to this RFP. The questions are to be submitted in writing to procurement@spc.int with the subject line: **Clarification RFP22-3712**. The deadline for submission of clarifications is **8/07/2022** by **4.00PM Fiji Time**.

Details will be kept of any communications between SPC and bidders. This assists SPC to ensure transparency

of the procurement process. While SPC prefers written communication in the RFP process, at any point where there is phone call or other conversation, SPC will keep a record or a file note of the exchange with prospective bidders.

2.4 Evaluation

Validity

Each proposal will be assessed for compliance with the submission requirements by the Bids Opening Committee. At this stage, basic due diligence will also be undertaken.

To assist in the examination, evaluation and comparison of proposals, SPC may ask the bidder for clarification of its proposal or additional information. The request for clarification will be in writing.

Technical

All valid proposals will be assessed against the technical evaluation criteria set out in Part 4. The criteria are provided with weighted scores according to the relative importance of each. SPC will not change the evaluation criteria set out in the RFP at any stage of the procurement process. Any changes in the evaluation criteria will result in the RFP process being re-issued.

Bidders are expected to familiarise themselves with local conditions and take these into account in preparing their proposal. Where minimum qualifications are set as specific evaluation criteria, these could include educational qualification, professional accreditation or certification, licensing, experience and expertise.

Pre-Bid Meeting

A Pre-bid Meeting has been planned on 28th June 2022 from 9am to 11am Yap Local Time. The pre-bid meeting will be undertaken virtually via Zoom. Bidders who are interested to attend the pre-bid meeting must register their attendance through the SPC procurement email (procurement@spc.int) by 23rd June 2022 no later than 4pm Fiji Time.

Shortlisted bidder's presentation

Bidders that are short-listed during the RFP evaluation process shall be required to conduct a presentation to, and respond to queries of, SPC's Procurement Technical Evaluation Committee. The bidders will be provided an opportunity to provide an overview of the operational aspect of the services they are proposing

Financial

Any bids that pass the minimum technical evaluation requirements will pass onto financial evaluation.

During the financial evaluation, if there is a discrepancy between the unit price and the total price, the lower price shall prevail. If there is a discrepancy between words and figures the amount in words will prevail.

The total cost of the proposal is to be inclusive of any taxes and is not subject to revision.

2.5 Contract award

SPC may award the contract once the Procurement Committee has determined that a bidder has met the prescribed requirements and the bidder's proposal has been determined to be the most responsive to the RFP documents, provide the best value for money and best serve the interests of SPC.

SPC's [General Terms and Conditions of Contract](#) will apply to any contracts awarded under this RFP, unless otherwise agreed. Any requested changes to the General Terms and Conditions of Contract must be foreshadowed in the submission.

The award of the contract will be made by contract signed and dated by both parties.

2.6 Key dates

Please see the proposed procurement timetable in the table below. This timetable is intended as a guide only and while SPC does not intend to depart from the timetable, it reserves the right to do so at any stage.

STAGE	DATE
RFP advertised	17/06/2022
Pre-Bid Meeting	5/07/2022
Deadline for seeking clarification	8/07/2022
RFP Closing Date	22/07/2022
Award of Contract	31/08/2022
Commencement of Contract	31/08/2022
Conclusion of Contract	30/06/2023

2.7 Legal and compliance

Child and vulnerable adult protection: SPC is committed to the well-being of children and vulnerable adults. All SPC contractors are required to commit to the principles of SPC's Child and Vulnerable Adult Protection Policy ([XI.G Manual of Staff Policies](#)). Breach of this requirement can result in SPC terminating any contract with a successful bidder. Any allegations of potential misconduct in relation to this RFP involving children or vulnerable adults should be sent to complaints@spc.int.

Confidentiality: Unless otherwise agreed by SPC in advance or where the contents of the RFP are already in the public domain when **shared** with the bidder, bidders shall at all times treat the contents of the RFP and any related documents as confidential. SPC will also treat the information it receives from the bidders as confidential.

Conflict of interest: Bidders must take all necessary measures to prevent any situation of conflict of interest. You must notify SPC in writing as soon as possible of any situation that could constitute a conflict of interest during the RFP process. If you have any familial connection with SPC staff, this must be declared, and approval will then be sought for you to engage in the RFP process. Breach of this requirement can result in the exclusion of the bidder from the RFP process or in SPC terminating any contract with a successful bidder.

Cost of preparation of quotations: Under no circumstances will SPC be liable for any proposal submission costs, expenditure, work or effort that you may incur in relation to your provision of a proposal (including if the procurement process is terminated or amended by SPC).

Currency, validity, duties, taxes: Unless specifically otherwise requested, all proposals should be in USD and must be net of any direct or indirect taxes and duties and shall remain valid for 120 days from the closing date. The successful bidder is bound by their proposal for a further 60 days following notification they are the preferred bidder so that the contract may be awarded. No price variation due to escalation, inflation, fluctuation in exchange rates, or any other market factors shall be accepted at any time during this period.

Eligibility: Bidders are required to disclose to SPC whether they are subject to any sanction or temporary suspension imposed by any international organisation, or whether they are subject to bankruptcy proceedings. You may not be bankrupt or suspended, debarred, or otherwise identified as ineligible by any international organisation. Failure to disclose such information may result in debarment and termination of any contract issued to the bidder by SPC.

Fraud and corruption: SPC has zero tolerance for fraud and corruption. All contractors have an obligation to

report potential fraud and corruption. Breach of this requirement can result in the exclusion of the bidder from the RFP process or in SPC terminating any contract with a successful bidder. Allegations of potential misconduct by an SPC staff member or contractor involving fraud or corruption can be sent to complaints@spc.int.

Good faith: The information in this RFP is provided by SPC in good faith. No representation, warranty, assurance or undertaking (express or implied) is or will be made, and no responsibility or liability will be accepted by SPC in relation to the adequacy, accuracy, completeness or reasonableness of this RFP or any information provided by SPC in relation to this RFP.

Modifications: Any clarifications, corrections or modifications will be published on the SPC website prior to deadline. In the event a bidder has submitted a bid before the clarification, correction or modification, the bidder will be informed and may modify the bid. The modified bid will still need to be received before the deadline.

No offer of contract or invitation to contract: This RFP is not an offer to contract or an invitation by SPC to enter into a contract with you.

Privacy: The bidder is to comply with the requirements of applicable legislation and regulatory requirements in force for the use of personal data that is disclosed for the purposes of this RFP. SPC will handle any personal information it receives under the RFP in line with its [Privacy Policy](#), and the [Guidelines for handling personal information of bidders and grantees](#).

Right to amend, seek clarity, withdraw, not award: SPC reserves the right to: (1) amend, add to or withdraw all or any part of this RFP at any time, or to re-invite bids on the same or any alternative basis; (2) seek clarification or documents in respect of any bidder's submission; (3) choose not to award a contract as a result of this RFP; (4) make whatever changes it sees fit to the timetable, structure or content of the procurement process, depending on approvals processes or for any other reason. Please note that while SPC will not change the evaluation criteria set out in the RFP without the RFP process being re-issued, SPC does reserve the right at the time of award of contract to vary the quantity of services and goods specified in the RFP and to accept or reject any proposal at any time prior to award of the contract without incurring any liability to the affected bidder or any obligation to inform the affected bidder/s of the grounds for SPC's action.

Right to disqualify: SPC reserves the right to disqualify: (1) any bidder that does not submit a proposal in accordance with the instructions in this RFP; (2) any bidder that misrepresents information to SPC; (3) any bidder that directly or indirectly canvasses any SPC employee concerning the award of a contract.

Use of material: Bidders shall not use the contents of the RFP or any related material for any purpose other than for the purpose of considering submitting, or submitting, a bid to SPC.

Warranty, representation, assurance, undertaking: The bidder acknowledges and agrees that no person has any authority to give any warranty, representation, assurance or undertaking on behalf of SPC in connection with any contract which may (or may not) follow on from this RFP process.

2.8 Complaints process

Bidders that consider they were not treated fairly during any SPC procurement process may lodge a protest. The protest should be addressed to complaints@spc.int. The bidder must provide the following information: (1) full contact details; (2) details of the relevant procurement; (3) reasons for the protest, including how the alleged behaviour negatively impacted the bidder; (4) copies of any documents supporting grounds for protest; (5) the relief that is sought.

Part 3: Specification of Goods

Project Title: EU FSM Sustainable Energy (EU FSM.SE) Project.

A. Project Description

Ulithi atoll consists of 40 islets surrounding a lagoon about 22 miles long and 15 miles within Yap state in the Federated states of Micronesia. The atoll is located around 129 miles from Yap proper, the main state capital island for Yap. Falalop is one of the four inhabited islets on Ulithi Atoll and can be reached by Ship on a monthly basis or by plane twice per week. Infrastructure in Falalop consist of a road network that links the communities, a runway and an island grid that provides power to 130 residential and commercial customers. Falalop does not have a wharf or Jetty which means that existing vessels operating in Yap cannot dock by the island but out at sea to which smaller paanga type boats deliver goods and items to Falalop.



Map 1: Map of Ulithi Atoll and Falalop

Under Output 4 of the EU FSM Sustainable Energy Project, the national Government of FSM through the Pacific Community (SPC) with funding from the European Union will be supporting the *Yap State Public Service Corporation* (YSPSC) to increase Falalop's electricity generation capacity through Renewable Energy Systems with Battery Backup.

The Project plans to construct a new solar PV plant with Battery Energy Storage System (BESS), including solar PV ground mounted railings and base which will have a 3phase 60kWp grid-tied system with backup using DC-Coupled PV which will be connected to the existing Island network that is operated by YSPSC. The installation works will be at the YSPSC compound or premises that also houses the island power plant.

This RFP is for the supply of all the equipment required for a fully operational PV system connected to the grid at the 3-phase pole mounted transformers. **The supplier is to ship all goods to Yap Port in Yap Proper, FSM only.** YSPSC will then be responsible for shipping the goods from Yap Proper to Ulithi Falalop, install and wire the 60 kWp solar PV grid tied system and connect it to the island grid. YSPSC will undertake the final testing and commissioning of the system.

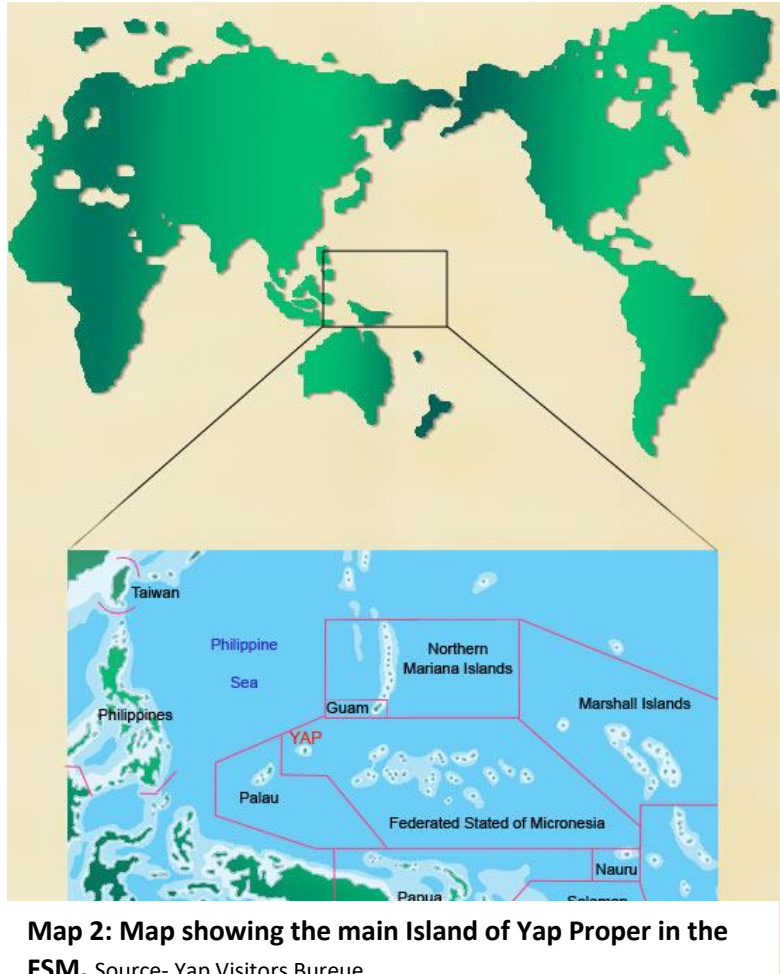

Map 2: Map showing the main Island of Yap Proper in the FSM. Source- Yap Visitors Bureau

B. Delivery specification

1. The bidder is required to deliver the solar PV system to the main wharf in Yap Proper, FSM. Upon arrival in Yap Proper, the Solar PV System and all accessories shall be inspected and signed off by YSPSC or alternative nominated SPC representative onsite. The Government of FSM will be responsible for the custom clearance.
2. The delivery date shall be stated clearly in the offer and it is up to the bidder to decide on the optimum method of delivering the supplies (air freight, sea-freight or a combination of these).
3. The delivery should be within the period specified and agreed by contract. After 30 days of delay without prior notification or explanation from the supplier on the reasons for delay, SPC will therefore reserves the right to cancel the contract.
4. Proposed delivery dates within the specified period will have no repercussion upon the evaluation of the bids. The delivery period may be negotiated with the successful bidder however anticipated non-compliance should be specified within the submitted bid.
5. The bidder is to ensure that all components are packaged and successfully transported to the main wharf in Yap Proper, Yap State, FSM. All proposal costs (Annex 5) as part of the submission should be inclusive of any or all applicable taxes and customs duties enroute. Before signing of contract, the shipping schedules, including ETD from country of supply and ETA at final destination should be submitted to the EU FSM.SE Project Manager for approval.
6. The solar PV System and Accessories shall be transported in a proper manner to prevent any transportation related damage and delivered in the condition as per expectation of the client. It is the responsibility of the bidder to ensure that the Solar PV system and all other accessories are insured until such time the delivery is cleared and accepted by the receiver of the shipment. The bidder is to indicate all the risks that are associated with the supply logistics, and how to mitigate the risks.

7. The bidder will be responsible for settling any transportation-related damage claims and will be responsible for replacing the Solar PV parts or accessories, at the request of SPC in a timely manner. The bidder must also provide marine insurance and include INCOTERM to be used.
8. Following award notification, and during negotiation leading to the signing of contract, the bidder will further be expected to finalise the following items:
 - 8.1. Secure the final design and supply specifications of the Solar PV system to be approved by YSPSC; and
 - 8.2. Finalise the shipping schedules, including ETD from country of supply and ETA at final destination should be submitted to the EU FSM.SE Project Manager for approval.

C. Institutional arrangement

1. The bidder will be responsible directly to the FSM.SE Project Manager for the delivery of the goods and services in line with the specifications mentioned in part B and C above. The bidder must meet FSMs biosecurity and quarantine requirements for the Solar PV Plant. The bidder must meet other relevant FSM's quarantine arrangement in the case of an overseas supplier.
2. The bidder shall keep the FSM.SE Project Manager informed on each stages of the delivery process and the schedule for training. Once the PV system leaves the country of supply, the bidder should immediately submit the export invoice, Bill of Lading and marine insurance cover.
3. The bidder is expected to work with the YSPSC Team or alternative nominated SPC representative onsite in assisting with the clearance from port during inspection of the Solar PV System and its accessories.

D. Evaluation criteria

1. Organisational Background

Organisational Background - Relevant Skills and Past Performance

Detailed evidence of the bidder's relevant experience must be submitted: Bidders shall provide details of two supply works that demonstrate their track record in completing works similar to this Proposal. The supplied contracts must have been completed or substantially completed within the last 5 years.

2. Technical Requirement

2.1) Training and Support Services

Ability and capacity to provide virtual training, and technical support during pre-installation, installation and commissioning. This also include the ability to provide support services to assist in trouble shooting, when required

2.2) Risks/Mitigation Measures

Ability to identify potential risks for the supply and delivery of the solar PV System and accessories as well as their quality. Effective measures are to be outlined which would be put in place to mitigate these risks among others:-

- *Delivery Schedule and Critical Path Activities*
- *Warranties and replacement to faulty items*
- *Alternative options and supporting justification*
-

2.3) Characteristics and specification of the Solar PV system and all its accessories

The bidder should supply the equipment's as mentioned in the Tender Specifications of **Part E** section E9 - Table of Equipment and Materials to be supplied. The bidder shall provide a complete set of documents

to describe features of the product including Brand, availability in stock, details about product quality, estimate lifetime and alternative options.

Bidders are also encouraged to fill supporting description as part of your response to the availability of items requested in Part E. including

- *Handling, Quality and Origin of the Equipment - The Solar PV systems and accessories to be supplied and delivered must be brand new and of high-quality manufacture.*
- *Equipment Warranties – For all supplied Solar PV system and accessories, the successful bidder will certify their high quality and conformity with norms and regulations in effect. The warranties must be transferable to YSPSC as SPC will not be the eventual owner of the 60 KWP grid connect Solar PV with BESS setup in Falalop.*
- *Delivery Schedule and Critical Path Activities from date of notice of award*

3. Compliance

The successful bidder must comply with SPC terms and conditions and fully complete all the required submission forms

By submitting a bid and signing a contract, the successful bidder accepts responsibility for the supply and delivery of the Solar PV Systems and accessories and will ensure that the standards in the specification are fully met.

Indicative Schedule of Payments

Performance Security

- Based on the total value of the contract a performance security bond up to 10% of the value maybe required.
- The performance security will be in the form of:
 - a. a bank guarantee or irrevocable letter of credit, issued by a reputable bank.
 - b. cashier’s cheque or certified cheque.
 - c. performance bond; or
 - d. percentage of the total payment held as retention money until final acceptance.

Milestone/Outputs	Deadline	% Payment
Acceptance by YSPSC of the final design and supply specifications of the Solar PV system with signing of contract.	TBC	20%
Submission of Supply plan from sourcing, packing, and freighting	2-4 weeks after signing of contract	20%
Submission of shipping bill of lading, export invoice and other required documents to SPC	4-6 weeks after signing of contract	25%
Confirmation that the specified solar powered PV system and accessories have been received at main port in Yap Proper, FSM with inspection report.	12-16 weeks after signing contract	25%
Submission of completion report for trouble shooting support and virtual trainings offered to the YSPSC during installation and commissioning.	TBC	10%

E. TECHNICAL SPECIFICATIONS

Table of contents:

E1 - Project summary

E2 - Environmental and climatic conditions

E3 - PV modules

E4 - PV modules support structures

E5 - Battery charge controllers

E6 - Battery

E7 - Power inverters

E8 – Equipment locations, Cables and Accessories

E9 - Table of Equipment and Materials to be supplied

E10 - Diagrams and Photos

E1 - BACKGROUND AND PROJECT SUMMARY

Project summary:

Assuming average load in Falalop is 30kW, the goal is to produce 30% of RE by installing **60kWp of PV**, 61.2kW of inverter capacity, 12,000Ah 48Vdc batteries. Basically, this system will allow to produce the energy for the night (8 hours) and store it. The diesel generator could be switched off for 8 hours during the night. This will reduce fuel consumption by 30% and running hours of the diesel generator by 33%.

This document describes the basic engineering design, gives the specifications and list of material for the 60 kWp solar PV grid tied system to be installed in Ulithi Falalop, with backup system using DC-Coupled PV supplying 3 phase 208V/120V mini grid.

Examples of the PV wiring electrical diagrams, drawings, plans, layouts of the arrays and the building that will house the batteries, inverters, electronics are included in Part E10- Diagrams and Photos.

This Request for Proposal concerns the supply and delivery of all the components of this Solar PV System to Yap Proper. The supplier will ship all goods to Yap Port in FSM.

YSPSC will ship the goods from Yap Proper to Ulithi Falalop, install and wire the 60 kWp solar PV grid tied system and connect it to the island grid. YSPSC will undertake the final testing and commissioning of the system.

All power generated in Falalop to date is supplied through diesel generation with a total capacity rating of 130 KW (40kW (Cummins) and 90kW (CAT)) supplying power around 120 customers. Maximum demand for the Ulithi Falalop grid is around 70kW.

Shop building to house batteries, inverters and electronics:

The YSPSC shop building is located next to the power station building that houses the 2 island gensets. The Shop building has been identified by YSPSC to house the batteries, inverters, and electronics. During cyclone Maysak, the Shop building also had its roof blown away however this has been renovated and a full new roof has been installed. Other improvements are undertaken at the Shop building to enhance security and safety.

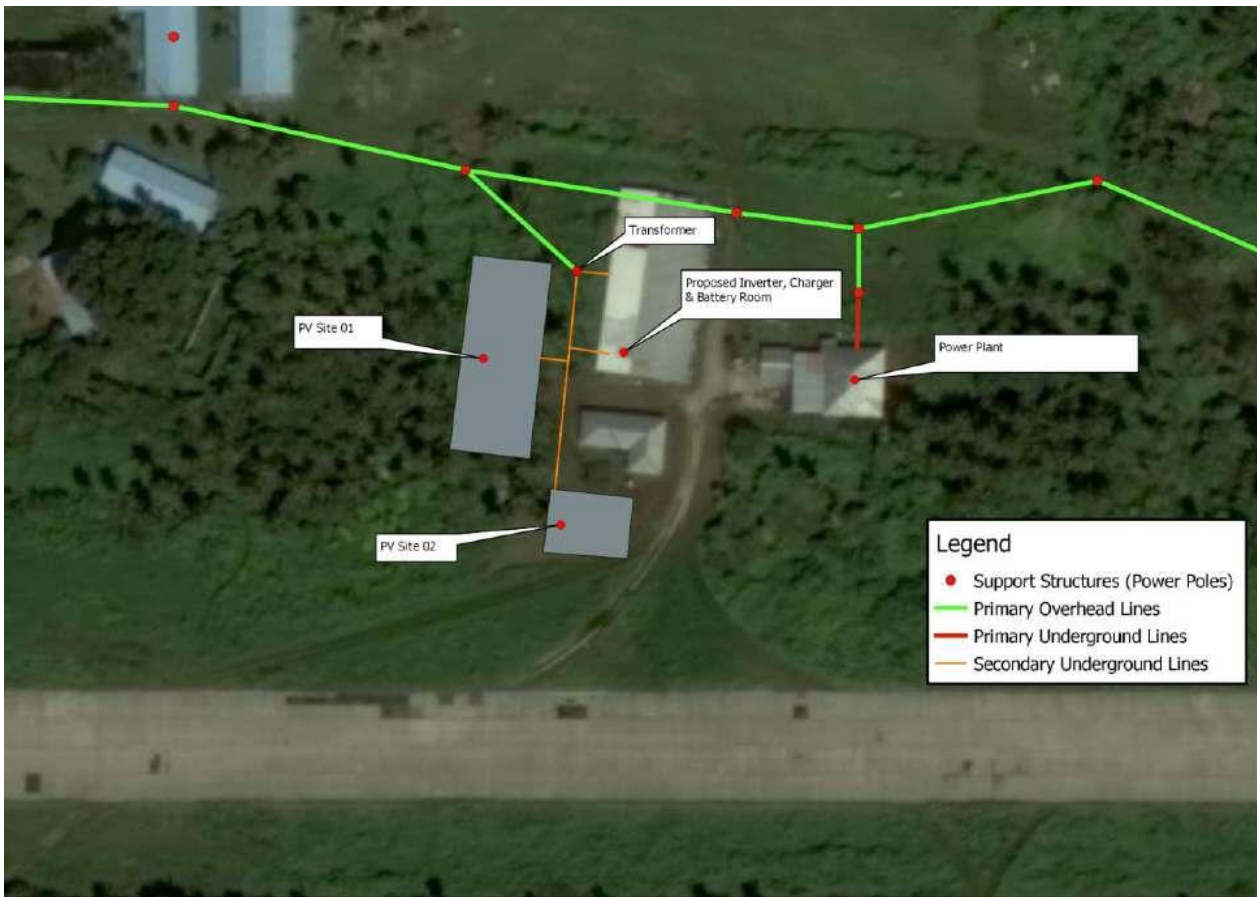

New solar PV sites, batteries/control room, and diesel generation feeding 4.16kV Island distribution network.

61.2kW Grid Tie with Backup System using DC-Coupled PV:

The DC-Coupled grid tie system based on 6 or 9 batteries inverters will self-consume the PV power before exporting the energy to the grid and maintain batteries in a fully charged state. The batteries will cycle through the bulk phase at the beginning of every day for maintenance.

Ratings are as follows:

Requirements	Ratings
Battery Inverter	Not less than 61.2kW
Battery Storage	12,000Ah 48V
PV Charge Controller	72kW
Bypass Capacity	400A peak (144 kVA)

Two examples of simplified electrical diagram for the project are illustrated in Part E10- Diagrams and Photos. The design is comprised of:

Power conversion equipment: Battery Inverters (nine or six North American electrical standards or IEC with required North American voltage and frequency i.e. 3 phase 208V / 120V 60Hz) and MPPT Charge Controllers (twelve MPPT - maximum continuous output current 100A - maximum array 6000W)

Balance of system (BOS): Power Distribution Panels (PDP), PV Disconnects, AC Combiner Box

Monitoring and control accessories: System Control Panel (SCP), communication and monitoring device (Com. Box or others), Battery Monitors

	Description
A	Battery Inverters (nine inverters 6800W (Continuous output power at 25°C) or six inverters 12000W (Cont. output power at 25°C)) are grouped into three clusters. One cluster consists of three inverters 6800W or two inverters 12000W. Each inverter is associated to one phase of the three phases. Each cluster is connected to its own battery bank. (Includes wiring of master(s) and slave(s))
B	MPPT Solar Charge Controller (twelve MPPT - maximum continuous output current 100A - maximum array 6000W) are grouped into three clusters. Each cluster consists of four MPPT solar charge controllers providing a total of 400 A charging current. Each MPPT is connected to a PV array of 5kVA.
C	Power Distribution Panels (PDP) house the AC and DC breakers integrating the inverter, the battery, and AC input and output.
D	The PV Combiner Box is intended to integrate the PV modules and the MPPT solar charge controllers. It houses PV string combiners and DC disconnects.
E	The Battery Monitor keeps track of the voltage, current, State of charge (SOC), and amp-hours in/out of a system. Also provides status of the battery to the connected devices on the communication network, such as allowing SOC- based Start and Stop from the Automatic Generator Start (AGS).
F	The communication and monitoring device(s) (Com. Box or others) enable configuration, control, and status reporting of devices connected to the network through a web browser user interface (UI). It also doubles as a data logger to record energy production/ consumption levels over hours/days/months/years and as a communication gateway for remote monitoring.
G	The System Control Panel (SCP) allows for a local LCD interface for easy access of the system, to set the system in operating or standby modes. Quick access to control or put all system devices in standby.
H	Power Meters to ensure that power flow is monitored, to enable remote monitoring and diagnostics of the system. In case an AC-Coupled PV inverter might back-feed to a generator, the power meter can be programmed to have a Digital I/O alarm set off when a reverse power flow is detected (disconnecting the inline external contactor with the PV inverter feed for a fixed period).
I	A network router to allow a network bridge between Com. Boxes. Industrial grade router that is capable of providing DHCP addresses to facilitate the installation process. Able to be configured for port-forwarding, support DYDNS services, or VPN.
J	A cellular modem to enable remote monitoring of the system. Industrial grade modem that is capable of remote configuration.
K	A bypass device (i.e. high current manual switch) to switch between the alternative power source and the battery-based power source. Its primary purpose is to provide a means to isolate the external contactor for the purpose of troubleshooting while maintaining a power supply to the local loads.

All equipment, devices and parts, materials, shall be compatible to build a coherent, safe, reliable, performant and long-lasting power system.

E2 - ENVIRONMENTAL AND CLIMATIC CONDITIONS

The installation site is near to the ocean and located in a high humidity, high ambient temperature climate. Typhoons (tropical cyclones/hurricanes) with winds exceeding 180 km/hr may strike the site. On Tuesday 31st March and Wednesday 1st April 2015, category 5 Typhoon Maysak made landfall on Yap islands, including Ulithi Falalop causing substantial damages:



Typhoon Maysak at peak intensity on April 1
Formed March 26, 2015
Dissipated April 7, 2015

Highest winds 10-minute sustained: 195 km/h (120 mph)
1-minute sustained: 280 km/h (175 mph)

Photos showing the destruction at the high school and the old solar PV site

Climate data for Ulithi													[hide]
Month	Jan	Feb	Mar	Apr	May	Jun	Jul	Aug	Sep	Oct	Nov	Dec	Year
Average high °C (°F)	30.6 (87.1)	30.6 (87.1)	30.7 (87.3)	31.2 (88.1)	31.3 (88.4)	31.0 (87.8)	30.7 (87.3)	30.8 (87.4)	31.1 (87.9)	31.6 (88.9)	31.3 (88.4)	30.8 (87.5)	31.0 (87.8)
Daily mean °C (°F)	27.4 (81.4)	27.3 (81.2)	27.6 (81.6)	27.9 (82.3)	28.1 (82.6)	27.7 (81.8)	27.4 (81.3)	27.3 (81.2)	27.5 (81.5)	27.9 (82.2)	27.9 (82.2)	27.7 (81.8)	27.6 (81.8)
Average low °C (°F)	24.3 (75.7)	24.1 (75.3)	24.4 (75.9)	24.8 (76.6)	24.9 (76.9)	24.3 (75.8)	24.1 (75.4)	23.9 (75.1)	23.9 (75.1)	24.2 (75.5)	24.5 (76.1)	24.6 (76.2)	24.3 (75.8)
Average rainfall mm (inches)	153.2 (6.030)	113.3 (4.460)	134.4 (5.290)	127.0 (5.000)	167.6 (6.600)	257.6 (10.140)	306.8 (12.080)	393.7 (15.500)	320.0 (12.600)	251.2 (9.890)	228.6 (9.000)	196.1 (7.720)	2,649.5 (104.31)

A high resistance to corrosion for all exposed materials, proper enclosures for sensitive equipment and components is required. The system should be designed to be able to reliably provide full continuous power capacity under the following conditions:

- Relative humidity up to 85%, non-condensing, for extended periods
 - Ambient Temperature range: 15°C to 45°C
 - Wind speeds of 180 km/h continuous for at least 12 hours with gusts to 200 km/h.
- Equipment shall additionally withstand the following conditions without damage or loss of reliability:
- High levels of solar ultraviolet radiation
 - A very corrosive marine-coastal environment with a high air-borne salt content
 - A rural environment with a high presence of coral dust and insects
- Array connection and combination boxes must include wire entry and cover seals to prevent insects and water entry. All exterior wiring must be insulated with materials that do not degrade when exposed to ultraviolet radiation.

E3 - PV MODULES

Monocrystalline or Polycrystalline Photovoltaic Module
Designed for off-grid applications
with following specifications **or substantially equivalent:**

Ideally 200 Watts, 24 Volts but see **Wp CAPACITY AND CELL CONFIGURATION** below

Electrical specifications

Open-Circuit Voltage Voc 44.56V
Optimum Operating Voltage Vmp 36.70V
Short-Circuit Current Isc 5.99A
Optimum Operating current Imp 5.45A
Maximum power at STC Pmax 200W
Module Efficiency 15.72%
Operating Temperature -40°C to 85°C
Maximum System Voltage 1000V DC
Power Tolerance 0/ +5%
Nominal Voltage 24V
I-V Characteristics curve to be provided

Temperature characteristics

Nominal Operating Cell Temperature (NOCT) 45± 2degC
Maximum series Fuse / Current Rating 10A

Module characteristics

Module Dimensions, surface less than 1.4 square meter
Weight (to be provided)
Cells array & Numbers (to be provided)

Solar cells dimensions and type

Laminate: description

Front and back sides: description

Frame: Aluminum - description

Relative humidity: 0 to 100%

Resistance: 227g steel ball dropped from 1m high and **60 m/s wind**

Output: MC4 compatible connector cables

Standard Test Conditions: description

STC Irradiance 1000W/m², Module temperature 25°C, AM = 1.5

– or PV modules substantially equivalent with same or greater resistance to wind load and to flying objects impact.

WARRANTY & TEST CERTIFICATION

The PV modules shall be warranted to provide their rated output at standard conditions within ±15% for a minimum of 20 years under the harsh tropical, coastal conditions at the site.

PV modules of the model offered must have been tested at the ESTI (European Solar Test Installation) or an equivalently qualified institution (such as TUV Rheinland and ASU-PTL) using CEC Specifications No. 503 or certified according to the international standard IEC –

61215 (or latest, more recent standards).

CELLS & FRAME

Cells will be made of monocrystalline or polycrystalline silicon. PV modules must be framed with marine grade aluminum or stainless steel with appropriate seals to prevent water and corrosion damage to the active components of the panel.

COVER

High strength glass must be used for the transparent cover. The backing of the panel may be glass or other material impermeable to water that is accepted under the applicable international standards.

DIODES

Solar panels shall have bypass diodes built in.

CONNECTION BOX

The modules shall have a separate connection box on their back side that meets protection class IP65. The terminals must be clearly marked with + and – for the corresponding connections.

Wp CAPACITY AND CELL CONFIGURATION

Bidder will determine and propose the Wp capacity and cell configuration of the individual panels that provides the lowest overall cost for the mounted array while retaining the mechanical strength needed to meet the wind loading specification and the electrical requirements of the array.

MODULE INFORMATION

For the panel model selected, the bidder will include the following information:

- Voc, Isc, Impp, Vmpp, and Wp at standard conditions
- the relationship between temperature and module output
- The IV (current/voltage) curves for 600, 800, and 1000 W/m² solar inputs
- physical size and weight
- details of the materials used in construction, including the frame, the connection boxes, the backing material and the encapsulation material.
- Number of cells per panel
- Type of connections with the size of wires accommodated
- The results of type tests carried out on the module type at ESTI (or an equivalent institution) using the CEC Specifications No. 503 or to International standard IEC-61215 shall be provided.
- A statement of warranties in effect for the proposed module type must be provided

MANUFACTURER'S LABEL

On each module the following minimum information will be shown on the manufacturer's

label attached to each panel:

- Manufacturer's name
- Module model identification
- Module serial no.
- Rated power at standard conditions
- Voc
- Isc
- Date of manufacture
- Country of manufacture

Provisions for Lightning Arresters:

Type 1 Surge protective device – Max. Surge current 80kA

E4 - PV MODULES SUPPORT STRUCTURES

GROUND MOUNTED ARRAYS

Arrays shall be tilt at 15 °.

The arrays shall be mounted on a reinforced concrete structure built by YSPSC and very similar to how it is illustrated in Part E10-Diagrams and Photos on photo1, diagrams 1 & 2 (Layout and exact location of the arrays can be seen on photo 2 and the KMZ file indicated below photo 2)

The supplier / bidder shall provide all the metallic (aluminum) structure and hardware (i.e. mounting rails, U beams, brackets, nuts, bolts, washers, foundation bolts, bracings if necessary, etc. and clear mounting instructions and diagrams of such structure. This structure shall be certified as withstanding the wind loads corresponding to the wind speeds specified in this document, with no significant damages on the mounted PV modules and keeping them operational after the storms.

By experience, YSPSC concrete structure as shown on photo 1 in Part E10-Diagrams and Photos withstood Category 5 Typhoon Maysak extreme wind loads on two nearby islands of the Ulithi atoll. Based on this experience, YSPSC intends to build the same type of reinforced concrete structures.

The supplier shall provide anything else apart from the reinforced concrete structure so that the final installation meets the wind load requirement and this installation shall have a design life of at least 20 years. The site is flat and has thin sandy soil over porous coral rock. In particular, attention must be given to providing a structure sufficient to resist the vertical and horizontal forces, and vibrations on the array during high winds when the soil is also saturated due to heavy rainfall.

Ground mounted structures shall allow underside access to the modules with minimal need to disassemble the array for maintenance and repair.

All the PV modules will be fastened in such a way that if one PV module becomes loose, the others around remain tight on the mounting structure. In other words, securing and fasteners of each PV module must be independent from the others beside or next to it. This is to avoid any cascading effect of removal of PV modules during typhonic winds.

WEATHER RESISTANCE

All structures must be able to resist at least 20 years of outdoor exposure in the location's harsh tropical marine environment without any appreciable corrosion or structural fatigue.

MATERIALS

All hardware used for mounting panels to the structures and the structures to their supports must be marine grade stainless steel. There must be no direct contact between aluminium and other metallic components that can cause electrolytic corrosion of either material.

TECHNICAL SPECIFICATIONS AND DRAWINGS

The supplier / bidder shall provide full technical specifications and generic drawings of the proposed physical design showing the assembly of the mounting structures and the details of the mounting of the modules and their attachment onto the supporting structure. These must specifically include physical size, and details of materials. Sample drawings for a ground mounted array are provided as Drawings No.1& 2 in Part E10-Diagrams and Photos. The array mounting depicted in the sample drawings is indicative only and it is the responsibility of the bidder to ensure that their design meets the environmental requirements. In particular, the high wind loading may require additional cross bracing between metallic support poles. Any reinforced concrete structures remain the responsibility of YSPSC and is outside the scope of these specifications.

ENGINEERING CALCULATIONS

The supplier / bidder shall provide engineering calculations or any other proofs confirming that its proposed design will meet the requirements of the bid. This shall include:
wind loading calculation and/or (international and/or national) certifications

E5 - BATTERY CHARGE CONTROLLERS

Shall be:

Performant with MPPT optimized software algorithm and high efficiency,
Reliable,
Protected from dust and moisture from damaging internal components,
Easy to install, configure / program, control and monitor,
Equipped with Fault protection, rapid shutdown, and Data logging

TYPE

Battery charging will be managed by MPPT type charge controllers (multiple units operating in unison). The controllers' characteristics and the arrays configuration should be matched so as to provide the maximum daily energy delivery to the battery. Due to the harsh environmental conditions at the site and the need for high system reliability, it is required that the rated controllers capacity exceeds the maximum capacity required by the system design by at least 20%:

Twelve MPPT Solar Charge Controllers - maximum continuous output current 100A - maximum array 6000W - grouped into three clusters, **or substantially equivalent equipment and arrangement.**

Electrical Specifications

Maximum PV system voltage	300 Vdc or greater
Max. output power	6000 W (nominal 48 V systems)
Nominal battery system voltage	48 VDC
Charging range (Output)	20 to 67 VDC (or wider)
Maximum continuous output current	100 A
Programmable charging regulation	such as bulk, absorption, float, silent, equalization

Efficiency

Max. power conversion efficiency	95% or better (nominal 48 V)
----------------------------------	------------------------------

General Specifications

Standby Power Consumption	around 2.5 W or lower
---------------------------	-----------------------

Battery temperature sensor / compensation

Auxiliary output

Ambient air temperature for operation	-20 °C to 60 °C
---------------------------------------	-----------------

Regulatory Approvals / Certifications	UL1741 minimum
---------------------------------------	----------------

DISPLAY

LED indicators with compatible remote display and controller & network cabling,

Data logging included

Data logging and display can also be included in the controller to show the energy flow from the array to the battery at least on a daily basis

CONTROLLED OVERCHARGED PROVISION & OTHERS

The controller should have provision for providing a controlled overcharging of the battery to equalize battery cells and/or eliminate stratification if needed. This may be a manual or a programmed function.

All the necessary provisions shall be included for the Power Distribution Panel, Disconnect Switches & Electrical Protections, Energy Management, Control Panel, Automatic Generator Start, Battery Monitor.

WARRANTY STATEMENT

A statement of warranties in effect must be provided for each controller model proposed.

E6 - BATTERY

Industrial Batteries type **OPzS** (O Ortsfest / **stationary** Pz PanZERplatte / **tubular plate S** Flüssig / **flooded**) designed for reliable energy storage for renewable energy systems, network power and for critical systems requiring uninterrupted power supply.

The application is Off-grid Renewable Solar.

The technology must be well proven for decades in medium and large power applications. Main characteristics are robustness, long design life, operational safety, ideally suitable for use in solar power stations, power distribution companies, and safety equipment power supplies, in harsh environments:

- Optimized design for renewable energy applications with highest cycling ability and long life
- large electrolyte reserve – very long topping up intervals

Specifications:

Nominal capacity C120 at 25 °C: 4100 Ah

Very thick tubular positive plates for the most demanding applications

Up to 2800 cycles at 60 % depth of discharge (C10) with IU charging profile at 20 °C.

Enhanced performance for 48 V systems, IUI charging to reach 3000 cycles and more.

Designed in accordance with IEC 61427 and IEC 60896-11

Screw connectors for better contact and reliability

Dry-charged version with separate electrolyte

High quality transparent or translucent containers for easy maintenance

Block battery/ Single cell

Up to 3000+ cycles at 60% depth of discharge (using IUI charging at 20 °C)

Recyclable

Low maintenance

Total capacity of these stationary batteries: minimum 12,000Ah C100 in total for the three 48 Vdc banks together:

THREE banks - Each composed of 24 batteries 2 Volts (Nominal Voltage) 4100Ah C120 (4000Ah C100) Pb 1.85V/Cell (Vpc) at 25°C

Total: 72 products with all the accessories

Product type: OPzS according to DIN standards for solar applications

Accessories: complete links, racks and retaining trays

Include the Acid which must be stored separately in plastic containers

Basic requirements

A bank shall consist of 24 cells each providing 2V connected in series. Paralleled cells will not be accepted. The basic requirements for the battery include 12 years or longer rated service life when the average DOD is 20%.

Under normal operating conditions (average daily cycling to 20% depth of discharge) the maintenance requirement should be minimal with water replacement expected to be needed no more often than every six months. Catalytic recombination caps may be used to achieve this requirement. Caps should be of a type that prevents flame propagation into a cell.

At an average daily duty cycle of 20% depth of discharge at C₁₀ rate, the battery should achieve 5,000 cycles or more of operation. Maximum allowable DOD in service will be 80%.

The battery will be IEC 60896-11:2002 compliant.

Delivery conditions

The battery will be delivered in a dry charged condition. Its shelf life at 30°C must be 2 years or more if stored in its original packing.

Transportation

The cell case must be mechanically strong enough to allow cells to be transported individually by small boat and carried by hand or manually powered wheeled cart over flat land for 2 km or less. Conditions required for transport of the cells must be provided and will include information as to any requirement for maintaining of a specific cell orientation during transport.

Electrolyte

Sufficient tropical rated (25°C to 40°C) electrolyte will be provided with at least 10% more volume delivered than is needed for fully filling the battery.

Self discharge

Self discharge shall not exceed 3% per month.

Cabling

Cell inter-connection cables with the proper connection lugs are to be provided with the batteries. They shall be of the correct type and size for the inter-connection of 24 of the supplied cells in series. The cells are expected to be arranged in two side by side banks of 12 cells. (This will be repeated three times as there are 72 cells in total)

Required information

The following information are to be provided:

- Coulombic and energy efficiency
- Ah capacity at C₁₀ to C₁₀₀ discharge rate conditions
- Specific gravity vs. cell voltage curves
- Curves or tables for cycle life vs average DOD
- Physical characteristics including weight dry and wet, height, width, length, connection post dimensions, case material and cell cap type.
- Complete English language manuals for handling, filling, initial charging, installation, operation and maintenance
- Warranty terms and procedures for making warranty claims

Battery Monitor

A reliable battery monitor device shall be supplied with functionalities such as:

Data logging, display to show voltage, current, Ah, remaining capacity & hours
Information parameters are shared with inverters, MPPT solar charge controllers, Automatic Generator Start module, System Control Panel via network connectivity, enhancing performance

Monitors important data, stores, view historical events to evaluate usage patterns and battery health

Balancing of multi-battery bank system for clustered inverter system

Detects battery strings imbalance before performance is impacted

Battery Balancer to maximize service life of series-connected lead-acid batteries

Warning can be generated by measuring midpoint voltage

Simplifies installation and customizes settings

IoT ready, remotely monitor, troubleshoot, upgrade firmware, update software

Connections for network and battery signals / Quickly connects with standard cable

Indicates hours of battery-based runtime and battery bank state of charge

Integrates with inverters / energy management

Understands hours of available battery-based autonomy

Prevents increased current draw in case of alarm

Remaining time at current rate of discharge

Bi-stable alarm relay / Programmable visual, audible alarm / Programmable relay

Enables state of charge triggers for AGS module control of diesel generators

E7 - POWER INVERTERS

TYPE

Inverters will be configured for three phase output 120V/ 208V, 60 Hz pure sine wave power and will operate on a DC input of a nominal 48V that may vary from 42V to 60V without causing any reduction in AC power quality. The rating of the inverters system shall not be less than 61.2kW Continuous output power at 25°C.

The Battery Inverters could be arranged as follows:

Solution 1: Nine inverters 6800W Continuous output power at 25°C

or

solution 2: Six inverters 12000W Cont. output power at 25°C

or

Any other reliable solutions i.e. a failure of one component of the system will not stop the entire system which will be able to provide a derated power on the 3 phases until the component is replaced.

The inverters will be grouped into three clusters, one cluster consisting of three inverters 6800W (solution 1) or two inverters 12000W (solution 2). Each inverter is associated to one phase of the three phases. Each cluster is connected to its own battery bank. (Includes wiring of master(s) and slave(s))

Specifications Solution 1:

Adaptable single-phase and three-phase inverter/charger system with grid-tie functionality and dual AC power inputs.

Monitoring and automated generator control modules.

Clusters of 61.2kW

Grid-interactive and off-grid, solar and backup power applications.

Excellent load starting with high 30-minute and 5-second power

Performs in hot environments up to 70°C

Solar prioritization, load shifting, peak shaving

Backup power with grid-tie functionality converts external DC power to AC power for export to the utility grid

Three phase systems 61.2kW

Supports DC coupled off-grid and grid-tie architectures

Easy to service with replacement boards and spare parts, monitor, troubleshoot

Reliable

Proven and recognized field performance

Easy to install

System configures quickly

Integrates both grid and generator power with dual AC inputs

Balance-of-system components integrates battery bank, solar charge controllers and generators

Easy commissioning of the entire system

Inverter AC output

Output power (continuous) at 25°C	6800 W
Overload 30 min / 60 sec at 25°C	8500 W / 12000 W
Output power (continuous) at 40°C	6000 W
Output frequency	60Hz

Output voltage	L-N: 120V+/-3%
Total harmonic distortion (THD) at rated power	< 5%
Idle consumption search mode	<8 W
Input DC voltage range	42 to 60 V (48 V Nominal)
Maximum input DC current	180 A
Peak Efficiency	95.7%
Operating air temperature range	-25°C to 70°C (power derated above 25°C)
Features	
System monitoring and network communications	
Intelligent features	Grid sell, peak load shave, generator support, prioritized consumption of battery or external DC energy
Auxiliary port	
Off-grid AC coupling	Frequency control
Regulatory approval	
Safety	UL1741

Specifications Solution 2:

Two AC inputs with integrated transfer switch:

can be connected to 2 independent AC sources, for example 2 generators will automatically connect to the active source

Two AC Outputs:

The main output (no-break functionality) takes over the supply to the connected loads when generator power is disconnected. This must happen in less than 20 milliseconds (Any equipment will continue to operate without disruption).

The second output is live only when AC is available on one of the inputs. Loads that should not discharge the battery can be connected to this output.

Three phase capability:

3 units configured for 3 phase output and two sets (or more) of three 15kVA units can be parallel connected to provide 72kW / 90kVA inverter power.

Solar energy: AC power available during grid failure:

Able to be used in off grid as well as grid connected PV.

Loss of mains detection software available.

System configuring:

Parallel and three phase applications easily and quickly configured

Off grid, grid interactive, self-consumption applications, involving grid-tie inverters and MPPT Solar Chargers

On-site Monitoring and control:

Battery Monitor, Multi Control Panel, laptop (USB)

Remote Monitoring and control & Remote configuring

Integrated Transfer switch

AC inputs (2x)

Input frequency: 45 – 65Hz

Power factor:1

Maximum feed through current (A) 2x100

Inverter

Input voltage range (VDC) 38 – 66V

Output Output voltage: 120V +/-2%

Frequency: 60Hz +/-0.1%

Cont. output power at 25°C (VA) 15000

Cont. output power at 25°C (W) 12000

Cont. output power at 40°C (W) 10000

Cont. output power at 65°C (W) 7000

Peak power (W) 25000

Maximum efficiency (%) 96

Zero load power (W) 110

Zero load power in Automatic Energy Saving mode (W) 75

Zero load power in Search mode (W) 20

Protection output short circuit / overload
battery voltage too high / too low
temperature too high

Bus communication port For parallel and 3 phase operation, remote monitoring and system integration

Operating temp.: -40 to +65 °C

Humidity (non-condensing): max. 95%

Safety Standards EN-IEC 60335-1, EN-IEC 60335-2-29, EN-IEC 62109-1

CONTINUOUS POWER

The inverter system must be able to provide continuous power under the full range of environmental conditions of temperature and humidity found at the site.

See: E2 - Environmental and climatic conditions.

SYNCHRONIZATION

The inverter system shall be capable of operating independently of any power source other than the batteries banks.

The system is also required to synchronize with an external power supply i.e. one of the 2 existing diesel generators, **or at minimum**,

it is required to take over the supply to the connected loads in the event of a grid failure when any diesel generator power is disconnected (note: the 2 existing diesel generators never run simultaneously). This must happen fast enough (less than 20 milliseconds) so that computers and other electronic equipment will continue to operate without disruption.

EFFICIENCY

The inverter system should have an operating efficiency of at least 80% at 10% of specified power and greater than 90% at 70% of specified power.

HARMONIC DISTORTION

Total harmonic distortion should be less than 5% on a resistive load.

GENERAL CONDITIONS

The inverter should be able to provide double the specified power for 5 seconds or more without damage.

Programming should not be lost if DC input power is disconnected.

The inverter system should be protected against damage due to:

- Overloading on the AC side of the inverter
- Short circuits on the AC side of the inverter
- Over temperature conditions
- Under-voltage and over-voltage on the DC side of the inverter

A statement of warranties in effect must be provided.

E8 - EQUIPMENT LOCATIONS, CABLES AND ACCESSORIES

EQUIPMENT LOCATIONS

Layout of the arrays, the control room with the solar charge controllers and the inverters, the battery room with the 3 battery banks, the diesel powerhouse with the 2 existing diesel generators and the step up on pole transformer bank to connect to the 4.16kV island grid is visible on the Google Earth kmz file that can be downloaded with the link below photo 2 in Part E10-Diagrams and Photos.. Approximate dimensions, distances and lengths can be deducted through Google Earth scale, ruler & measurements.

Battery mounting will be in accordance with European or U.S. standards for solar or telecommunications battery banks of comparable size.

CABLES

Wiring between the arrays and the power system rooms will be routed underground. Sufficient and adequate cabling of the proper size, length (see Google Earth kmz file) and type, for underground use, shall be provided. In all cases, the wiring between the arrays and the battery banks will not cause a voltage drop of more than 3% at the rated Isc of the arrays at standard conditions.

The battery banks and inverters system will be no more than four meters apart and the copper connecting wires will introduce no more than 2% voltage drop when the inverters are operating at rated capacity. All battery banks will consist of 24 cells, each providing 2V (nominal) connected in series.

POWER DISTRIBUTION PANELS AND OTHER ACCESSORIES

The following equipment and accessories shall be provided:

Electrical:

Distribution panels with
All necessary Electrical Protections AC & DC,
Contactors,
Manual Changeover Switch / Bypass Switch
Two Power Meters

Notes:

- The project summary and the electrical diagrams in Part E10-Diagrams and Photos. should be used as guidelines to supply the requested power system
- The supplier will give all the details of all the compatible products provided under this bid to come up with an electrical installation which shall be compliant with one of the following standards:
 - NEC National Electrical Code (US)
 - AS/NZS 3000 wiring rules (AU & NZ)
 - NF C 15-100 (FR)
 - IEC 60364 (International) particularly IEC 60364-7-712
 - YSPSC prefers NEC compliant installations but also accepts International Standards, Australian/ New Zealand/ French/ German/ European standards for its

own renewable energy installations (not accessible by the public)
provided the installation is compatible with the standard American voltages and frequency indicated in these technical specifications.

Control & Communications:

System Control Panel (SCP)
Communications Box / devices
Network Router Industrial Grade
Cellular Modem

Automatic Generator Start with main functions such as:

- automatically activates or stops a generator in response to changing power requirements
- shares status information with other devices
- monitors user-programmable parameters, such as battery voltage, state of charge, or grid power
- activates the generator in response to any changes.

Note:

YSPSC is open to any control & communications solution(s) which is specific to well known manufacturer(s) provided they are reliable, simple enough for its remote island operation, suitable in the harsh marine environment and offering the basic functions described in the project summary (any proposal(s) from the manufacturer(s) shall be detailed in nature and price so that YSPSC may decide if these options are beneficial in regard to their cost)

E9 – TABLE OF EQUIPMENT AND MATERIALS TO BE SUPPLIED

Main equipment is listed. The list is not exhaustive regarding the accessories. The supplier shall offer and provide all the equipment and all the necessary accessories to build a coherent, safe, reliable, performant and long-lasting power system.

No	Description	Refer to	Quantity
3.a	PV array The total capacity shall be no less than 60 kWp PV Combiner Boxes with PV string combiners and DC disconnects. Lightning Arresters	§ E3 § E1 D § E3	1 array
3.b	Spare solar panels. Exact replacement for panels, solar array.	§ E3	12 panels
4.a	Arrays mounting system compatible with the concrete foundations & concrete supports built by YSPSC on flat sites. Total array of 60kWp will be divided into sub-arrays. Shall include the concrete foundation bolts (concrete supports bolts). A complete list of components to be supplied by the supplier will be provided with the bid.	§ E4	A necessary
5.a	Set of MPPT battery solar charge controllers such as: twelve MPPT - maximum continuous output current 100A - maximum array 6000W - grouped into three clusters. Each cluster consisting of four MPPT solar charge controllers providing a total of 400 A charging current. Each MPPT connected to a PV array of 5kWp.	§ E5	1 set
5.b	Spare MPPT controllers Exact replacement for controllers	§ E5	2 units
6.a	Battery banks 2V (nominal) lead-acid cells of no less than 4100 Ah . Paralleling of cells is not permitted. Connecting cables to construct three 48V banks of cells included. Tropical rated electrolyte included. Complete racks and retaining trays included.	§ E6	72 cells
6.b	Spare battery cells. Exact replacement for cells used in battery banks	§ E6	3 cells
6.c	Battery Monitor keeping track of voltage, current, SOC, Ah in/out, providing status of battery to connected devices on the communication network, allowing SOC- based Start & Stop from the AGS.	§ E6	As necessary plus 1 spare
7.a	Power inverters Continuous capacity of no less than 61.2kW providing 120Vac each phase to neutral - 208Vac phase to phase at 60Hz . Inverter system will be powered from three 48Vdc battery banks (one for each phase). (nine inverters 6800W or six inverters 12000W grouped into three clusters)	§ E7	1 three phase assembly

7.b	Spare inverters. Exact replacement for inverters used in the main three phase installation	§ E7	2 units
8.a	Balance of system components to complete the 3-phase power system. Complete list of components to be supplied shall be included in the offer. MPPT charge controllers, battery banks and inverter system will be housed in the existing YSPSC building, close to the arrays as pictured on photo 2 under Part E10-Diagrams and Photos. All wiring, connection boxes, hardware, necessary electrical protections, surge arresters, disconnectors and switches, mounting materials and hardware for batteries, inverters, charge controllers and other balance of system components to be installed in the powerhouse and from the arrays to the powerhouse shall be provided by the supplier. Sufficient and adequate cabling of the proper size, length and type, for underground use; Cables (DC & AC) from PV arrays to control room, batteries banks, power distribution panels, boxes, grid connection point, to diesel generators and to switches shall be provided.	§ E8	1 set
8.b	Power Distribution Panels (PDP) housing the electrical protections AC & DC: AC and DC breakers integrating the inverters, the batteries, and AC input and output.	§ E1 C § E8 § E10	As necessary
8.c	Communication & monitoring device(s) enabling configuration, control, status reporting of devices connected to the network through a web browser user interface	§ E1 F	1 set
8.d	System Control Panel / Interface	§ E1 G	1 set + spare
8.e	Power Meters to ensure that power flow is monitored, to enable remote monitoring and diagnostics of the system.	§ E1 H § E10	2
8.f	Network router / Industrial grade router	§ E1 I	1
8.g	Cellular modem / Industrial grade modem	§ E1 J	1
8.h	Bypass device / high current manual changeover switch External main contactor	§ E1 K § E10	1 set
8.i	Automatic Generator Start (AGS) activating or stopping the generator in response to changing power requirements, sharing status information with all devices, monitoring user-programmable parameters, battery voltage, state of charge, grid power	§ E1 E § E8	1

E10 – DIAGRAMS and PHOTOS

Solution1- High resolution layout of Solution 1 is provided in Separate PDF file and titled – “*Solution 1 Ulithi Falalop*”

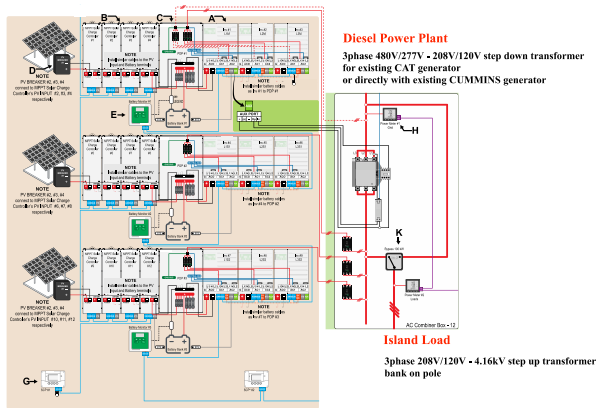

Solution2: High resolution layout of Solution 2 is provided in Separate PDF file and titled – “*Solution 2 Ulithi Falalop*”.

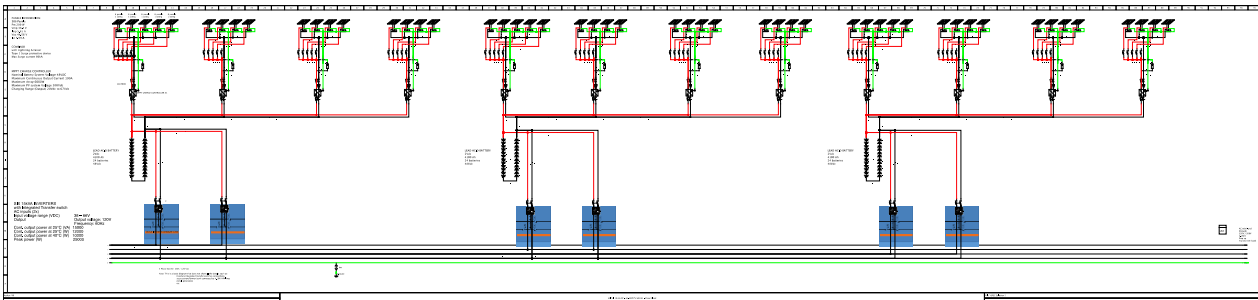



Photo1- Arrays tilt at 15 °

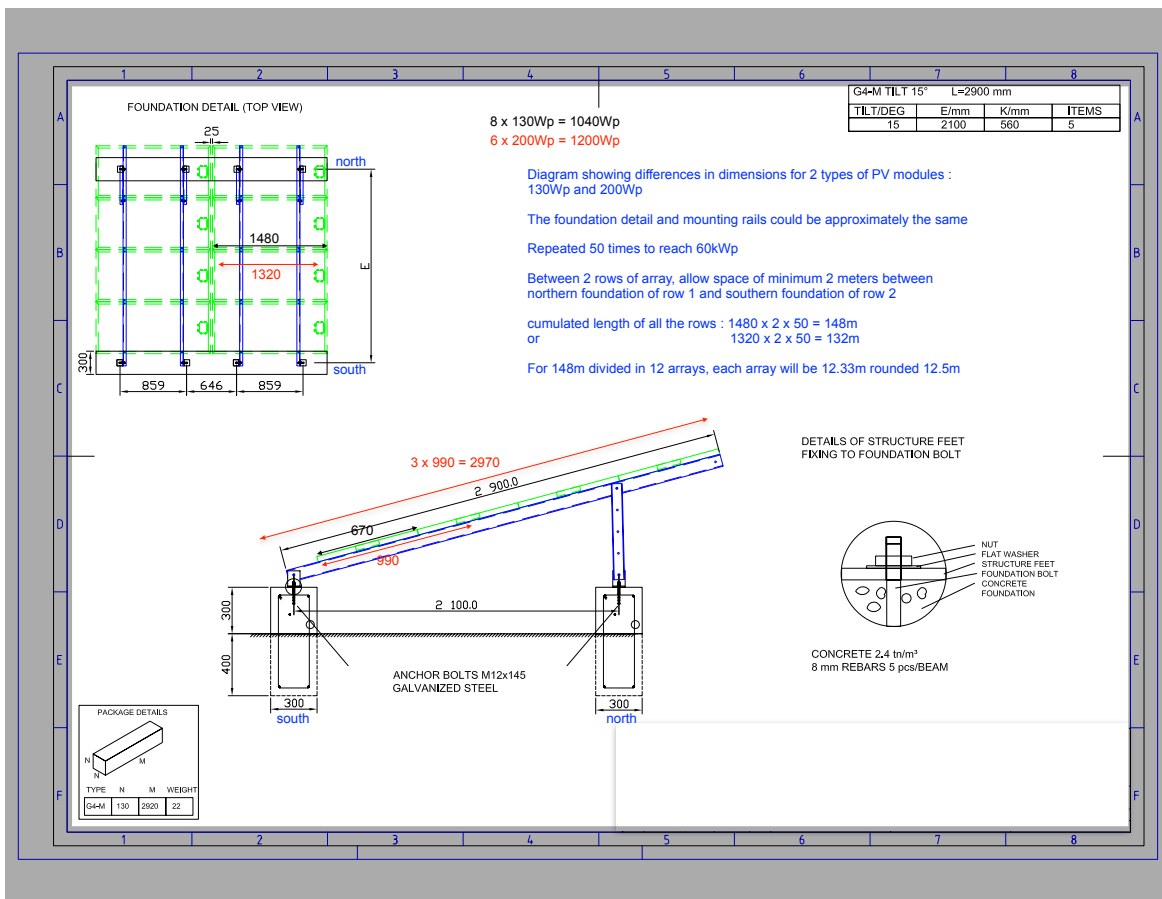

Diagram1- Arrays tilt at 15 °

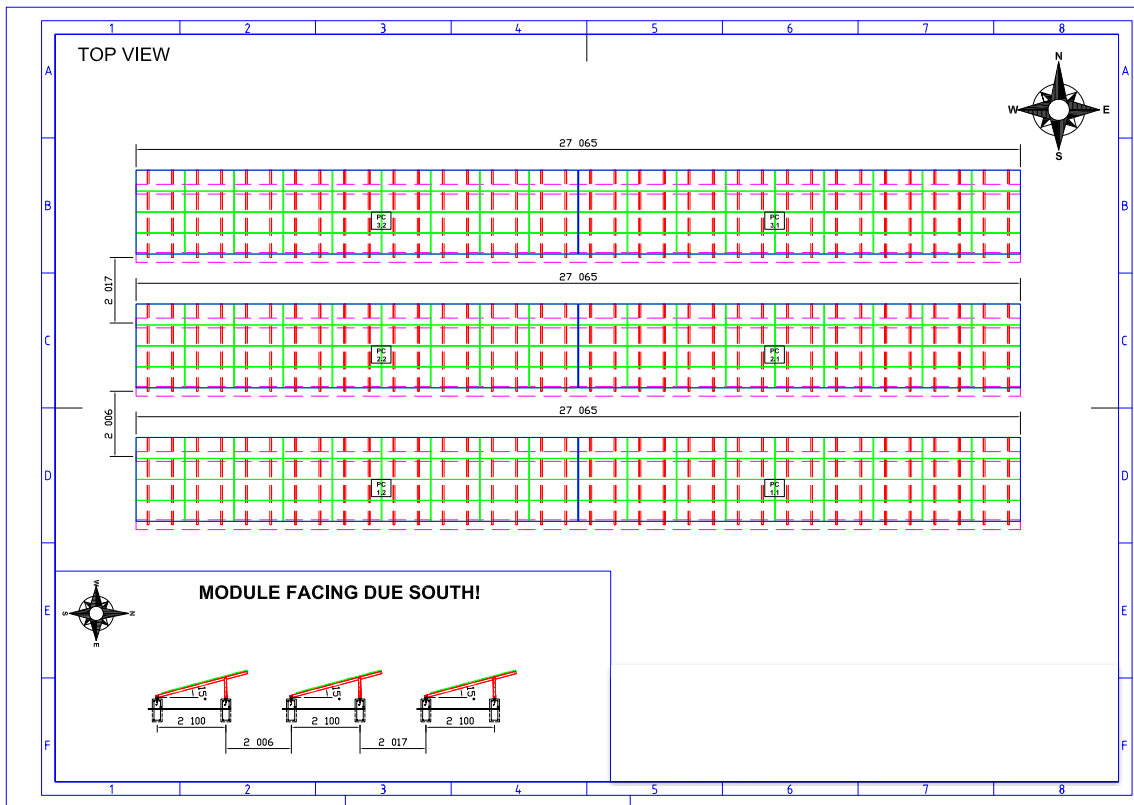
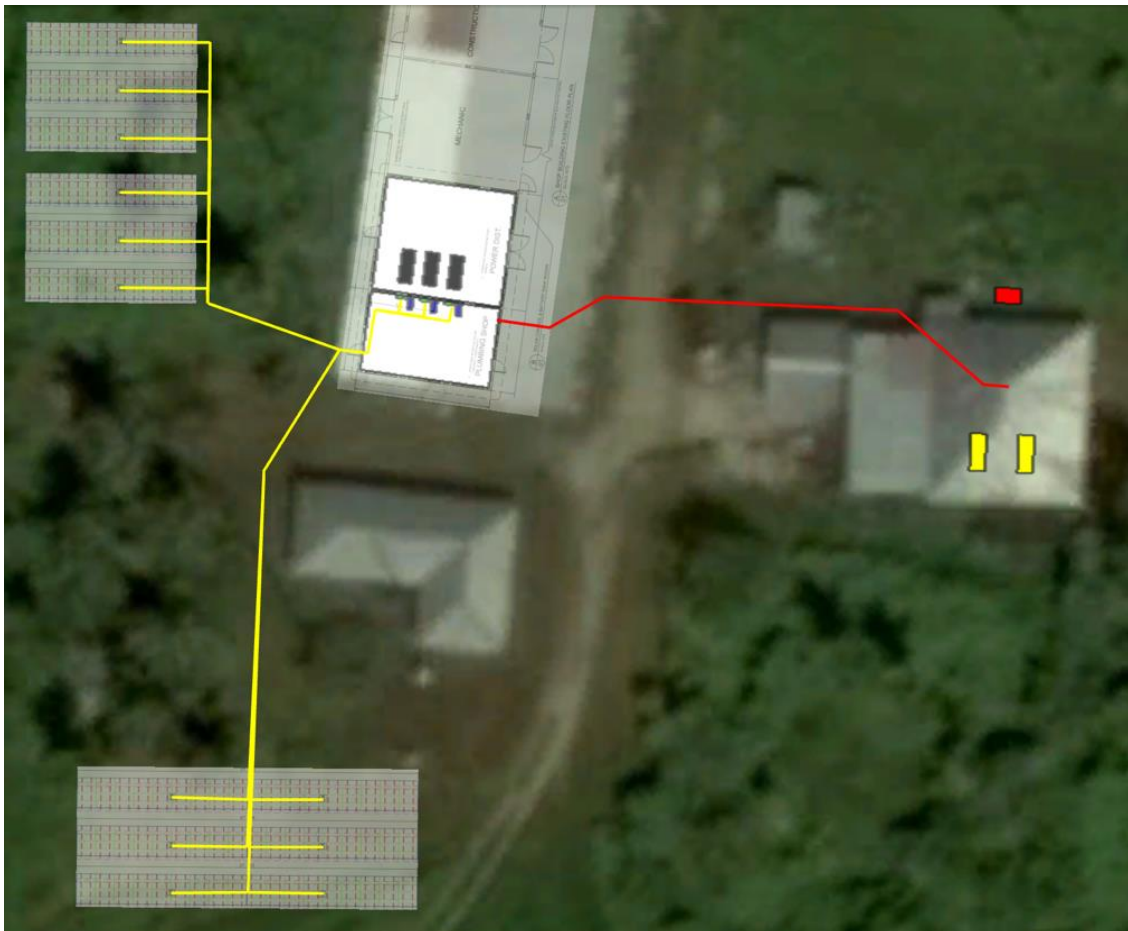

Diagram2 - Arrays tilt at 15 °



Photo2 – Ulithi Falalop 60kWp Layout: 30kWp + (2 x 15) kWp

High resolution layout of Photo 2 is provided in separate Google Earth KMZ file and titled “*Ulithi Falalop Arrays Layout Project*”



Part 4: PROPOSAL EVALUATION MATRIX

4.1 Competency Requirements & Score Weight

A two-stage procedure will be utilised to evaluate the proposals, with evaluation of the technical proposal being completed prior to any financial proposal being opened and compared.

The competencies which will be evaluated are detailed in [Part 3](#).

The evaluation matrix below also reflects the obtainable score specified for each evaluation criterion (technical requirement) which indicates the relative significance or weight of the items in the overall evaluation process.

The technical component, which has a total possible value of 700 points, will be evaluated using the following criteria:

Competency Requirements	Score Weight (%)	Points obtainable
Organisational requirements		
<ul style="list-style-type: none"> A company with at least 5 years' experience in supply prepayment meters Have in its office all the necessary equipment as required by this tender Have sound financial background (audited) over the 5 years Business Registration Certificate Liability and Professional Insurance 	<p>Mandatory requirements. Bidders will be disqualified if any of the requirements are not met</p>	
Technical requirements		
Training and Support Services		
<ul style="list-style-type: none"> Having the capacity to provide virtual training, and technical support during installation and commissioning Provide a virtual training plan for installation and commissioning Having the necessary support services to assist in trouble shooting, when required 	15%	140
Risk/mitigation measures		
<ul style="list-style-type: none"> Bidder to identify potential risks for the supply and delivery of the materials and fittings, likelihood of these risks and effective measures to mitigate these risks. Please prepare a risk matrix identifying the risks related to the supply chain for this procurement and provide mitigating measures. Please ensure to identify all risks relating to the current COVID situation including border closures. 	20%	140
Timelines, Quality Control and Management		
<ul style="list-style-type: none"> Ability to meet delivery timelines through providing the delivery schedule and critical path activities Ability to replace /provide spare parts as required and during any warranty period 	65%	420

<ul style="list-style-type: none"> • Provide itemised characteristics/specification of the Solar PV system and its accessories as listed in Annex II • Provide evidence on the supplied equipment components that they meet the required specifications • Provision of technical and user’s manuals for all the components including installation instructions • Provide clear clarifications and technical information on any variations to the required specifications • Provide Estimated lifetime of goods 		
Total Score	100%	700
Qualification score	70%	490

4.2 Financial evaluation

The financial component of the proposal will be scored on the basis of overall costs for the delivery of the goods and financial incentives and benefits provided to SPC. The lowest financial proposal will be awarded maximum 300 points and other financial offers and incentives will be awarded points as per the formula below:

$$\text{Financial Proposal score} = (\text{Lowest Price} / \text{Price under consideration}) \times 300$$

Part 5: PROPOSAL SUBMISSION FORMS

Annex 1: BIDDER'S LETTER OF APPLICATION

Dear Sir /Madam:

Having examined the Solicitation Documents, the receipt of which is hereby duly acknowledged, we the undersigned, offer to supply the required goods for the sum as may be ascertained in accordance with the Financial Proposal attached herewith and made part of this proposal.

We acknowledge that:

1. SPC may exercise any of its rights set out in the Request for Proposal documents, at any time;
2. The statements, opinions, projections, forecasts or other information contained in the Request for Proposal documents may change;
3. The Request for Proposal documents are a summary only of SPC's requirements and is not intended to be a comprehensive description of them;
4. Neither the lodgement of the Request for Proposal documents nor the acceptance of any tender nor any agreement made subsequent to the Request for Proposal documents will imply any representation from or on behalf of SPC that there has been no material change since the date of the Request for Proposal documents, or since the date as at which any information contained in the Request for Proposal documents is stated to be applicable;
5. Excepted as required by law and only to the extent so required, neither SPC, nor its respective officers, employees, advisers or agents will in any way be liable to any person or body for any loss, damage, cost or expense of any nature arising in any way out of or in connection with any representations, opinions, projections, forecasts or other statements, actual or implied, contained in or omitted from the Request for Proposal documents.

We undertake, if our proposal is accepted, to commence and complete delivery of all items in the contract within the time frame stipulated.

We understand that you are not bound to accept any proposal you may receive and that a binding contract would result only after final negotiations are concluded on the basis of the Technical and Financial Components proposed.

For the Bidder: *[insert name of the company]*

Signature:

Name of the Bidder's representative: *[insert name of the representative]*

Title: *[insert Title of the representative]*

Date: *[Click or tap to enter a date]*

Annex 2: CONFLICT OF INTEREST DECLARATION

INSTRUCTIONS TO BIDDERS

What is a conflict of interest?

A conflict of interest may arise from economic or commercial interests, political, trade union or national affinities, family, cultural or sentimental ties, or **any other type of relationship or common interest between the bidder and any person connected with the contracting authority** (SPC staff member, consultant or any other expert or collaborator mandated by SPC).

Always declare a conflict

The existence of a potential or apparent conflict of interest does not necessarily prevent the bidder concerned from taking part in a tender process. **However, the declaration of the existence of such a conflict by the persons concerned is essential and allows SPC to take appropriate measures to mitigate it and prevent the associated risks.**

Bidders are therefore invited to declare any situation, fact or link which, to their knowledge, could generate a real, potential or apparent conflict of interest.

Declaration at any time

Conflicts of interest may arise at any time during the procurement process or the implementation of a contract (e.g. new partner in the project) or as a result of a change in personal life (e.g. marriage, inheritance, financial transaction, creation of a company). If such a relationship is found and could be perceived by a reasonable person as likely to influence a decision, a declaration of the situation is necessary. In case of doubt, a conflict situation must be declared.

Declaration for any person involved

A declaration must be completed for each person involved in the tender (principal representative of the bidder, possible subcontractors, consultant, etc.)

Failure

Failing to declare a potential conflict of interest may result in the bidder being refused a contract or placed on SPC's list of non-responsible suppliers.

DECLARATION

I, the undersigned, *[name of the representative of the Bidder]*, acting in the name and on behalf of the company *[name of the company]*, declare that:

<input type="checkbox"/>	To my knowledge, I am not in a conflict-of-interest situation
<input type="checkbox"/>	There is a potential conflict of interest with regard to my <i>[Choose an item]</i> . relationship with <i>[name of the person concerned]</i> in his or her capacity as <i>position/role/personal or family link with the person concerned</i>], although, to the best of my knowledge, this person is not directly or indirectly involved in any stage of the procurement process
<input type="checkbox"/>	I may be in a conflict of interest with regard to my <i>[Choose an item]</i> relationship with <i>[name of the person concerned]</i> in his or her capacity as <i>position/role/personal or family link with the person concerned</i>], as this person is, to the best of my knowledge, directly or indirectly linked to the procurement process
<input type="checkbox"/>	To my knowledge, there is another situation that could potentially constitute a conflict of interest: <i>[Describe the situation that may constitute a conflict of interest]</i>

In addition, I undertake to:

- declare, without delay, to SPC any situation that constitutes a potential conflict of interest or is likely to lead to a conflict-of-interest;
- not to grant, seek, obtain or accept any advantage, whether financial or in kind, to or from any person where such advantage constitutes an unfair practice or an attempt at fraud or corruption, directly or indirectly, or constitutes a gratuity or reward related to the award of the contract;
- to provide accurate, truthful and complete information to SPC in connection with this procurement process.

I acknowledge that I and/or my company and/or my business partners who are jointly and severally bidding on the **RFP 22-3712** may be subject to sanctions such as being placed on SPC's list of non-responsible vendors, if it is established that false statements have been made or false information has been provided.

For the Bidder: *[insert name of the company]*

Signature:

Name of the Bidder's representative: *[insert name of the representative]*

Title: *[insert Title of the representative]*

Date: *[Click or tap to enter a date]*

Annex 3: INFORMATION ABOUT THE BIDDER AND DUE DILIGENCE

Please complete the following questionnaire and provide supporting documents where applicable.

VENDOR INFORMATION			
Are you already registered as an SPC vendor?		<input type="checkbox"/> Yes	<input type="checkbox"/> No
If 'No', please complete the form. If 'Yes', do you have any information to update?		<input type="checkbox"/> Yes	<input type="checkbox"/> No
If 'Yes', please complete the form. If 'No', sign directly the form without completing it			
(1) Please provide information related to your entity.			
Company name	<i>[Enter company name]</i>	Address	<i>[Enter address]</i>
Director/CEO	<i>[Enter name of the executive person]</i>	Position	<i>[Enter position of the executive person]</i>
Business Registration/License number	<i>[Enter company registration/license number (or tax number)]</i>		
Date of business registration	<i>[Enter date of business registration]</i>		
Country of business registration	<i>[Enter country of business registration]</i>		
Status of the entity:			
<input type="checkbox"/> For-profit entity (company), <input type="checkbox"/> NGO, <input type="checkbox"/> International organisation, <input type="checkbox"/> Government body, <input type="checkbox"/> University, <input type="checkbox"/> Association, <input type="checkbox"/> Research Institute, <input type="checkbox"/> Other: <i>[insert details]</i>			
(2) Please provide the following documents (or any other relevant documents according to your national legislation) to verify the legal existence of the entity, the authority of its officer and proof of its address:			
<input type="checkbox"/> Evidence of the power of attorney or board resolution granted to the officer to transact business on its behalf or any other document delegating authority <input type="checkbox"/> Certificate of business registration/license <input type="checkbox"/> Memorandum, Articles or Statutes of Association <input type="checkbox"/> Telephone or electricity bill in the name of the entity <input type="checkbox"/> Bank statement bearing the name of the entity			
(3) How many employees does your company and its subsidiaries have?		<i>[provide answer]</i>	
(4) Do you have professional insurance against all risks in respect of your employees, sub-contractors, property and equipment?		<input type="checkbox"/> Yes	<input type="checkbox"/> No
(5) If 'no', what type of business insurance do you have?		<i>[provide answer]</i>	
(6) Are you up to date with your tax and social security payment obligations?		<input type="checkbox"/> Yes	<input type="checkbox"/> No
(7) Is your entity regulated by a national authority?		<input type="checkbox"/> Yes	<input type="checkbox"/> No
<i>If you answered 'yes', please specify the name:</i>		<i>[Insert name of the national regulation authority]</i>	
(8) Is your entity a publicly held company?		<input type="checkbox"/> Yes	<input type="checkbox"/> No
(9) Does your entity have a publicly available annual report?		<input type="checkbox"/> Yes	<input type="checkbox"/> No
<i>Please send SPC your audited financial statement from the last 3 financial years if available</i>			

DUE DILIGENCE			
(10) Does your entity have foreign branches and/or subsidiaries?		<input type="checkbox"/> Yes	<input type="checkbox"/> No
<i>If you answered 'yes' to the previous question, please confirm the branches.</i>			
– Head Office & domestic branches		<input type="checkbox"/> Yes	<input type="checkbox"/> No
– Domestic subsidiaries		<input type="checkbox"/> Yes	<input type="checkbox"/> No
– Overseas branches		<input type="checkbox"/> Yes	<input type="checkbox"/> No
– Overseas subsidiaries		<input type="checkbox"/> Yes	<input type="checkbox"/> No
(11) Does your entity provide financial services to customers determined to be high risk			

including but not limited to:					
Foreign Financial Institutions	<input type="checkbox"/> Yes	<input type="checkbox"/> No	Casinos	<input type="checkbox"/> Yes	<input type="checkbox"/> No
Cash Intensive Businesses	<input type="checkbox"/> Yes	<input type="checkbox"/> No	Foreign Government Entities	<input type="checkbox"/> Yes	<input type="checkbox"/> No
Non-Resident Individuals	<input type="checkbox"/> Yes	<input type="checkbox"/> No	Money Service Businesses	<input type="checkbox"/> Yes	<input type="checkbox"/> No
<input type="checkbox"/> Other, please provide details:			[Provide details]		
(12) If you answered 'yes' to any of the boxes in question 11, does your entity's policies and procedures specifically outline how to mitigate the potential risks associated with these higher risk customer types?				<input type="checkbox"/> Yes	<input type="checkbox"/> No
If you answered 'yes', please explain how:			[Provide explanation]		
(13) Does your entity have a written policy, controls and procedures reasonably designed to prevent and detect fraud, corruption, money laundering or terrorist financing activities?				<input type="checkbox"/> Yes	<input type="checkbox"/> No
If 'yes', please send SPC your policy in English.					
(14) Does your entity have an officer responsible for anti-corruption, or anti-money laundering and counter-terrorism financing policy?				<input type="checkbox"/> Yes	<input type="checkbox"/> No
If yes, please state that officer's contact details:			[Insert name and contact details of your officer in charge]		
If 'no', what process does your entity have in place to prevent and detect money laundering or terrorist financing activities?				[provide answer]	
(15) Has your entity or any affiliated entity ever filed for bankruptcy?				<input type="checkbox"/> Yes	<input type="checkbox"/> No
(16) Have any of the entity's current or former directors or CEO filed for bankruptcy?				<input type="checkbox"/> Yes	<input type="checkbox"/> No
(17) Has your entity ever been the subject of any investigations or had any regulatory or criminal enforcement actions resulting from violations of any laws or regulations, including those relating to money laundering or terrorism financing?				<input type="checkbox"/> Yes	<input type="checkbox"/> No
If you answered 'yes', please provide details:			[Provide details]		
(18) Has the director or CEO of your entity ever been the subject of any investigations or had any regulatory or criminal enforcement actions resulting from violations of any laws or regulations, including those relating to money laundering or terrorism financing?				<input type="checkbox"/> Yes	<input type="checkbox"/> No
If you answered 'yes', please provide details:			[Provide details]		

SOCIAL AND ENVIRONMENTAL RESPONSIBILITY (SER)

(19) Does your entity have a written policy, controls and procedures to implement its Social and Environmental Responsibility (SER) commitments?				<input type="checkbox"/> Yes	<input type="checkbox"/> No
If yes, please send SPC your policy in English.					
Does your Policy cover the followings?					
<input type="checkbox"/> Child protection <input type="checkbox"/> Human rights <input type="checkbox"/> Gender equality <input type="checkbox"/> Social inclusion <input type="checkbox"/> Sexual harassment, abuse or exploitation <input type="checkbox"/> Environmental responsibility					
Please, outline the major actions you have undertaken in these areas:			[provide answer]		
(20) Does your entity have an officer responsible for Social and Environmental Responsibility (SER)?				<input type="checkbox"/> Yes	<input type="checkbox"/> No
If yes, please state that officer's contact details:			[Insert name and contact details of your officer in charge]		
If 'no', what process does your entity have in place to ensure your social and environmental responsibility?				[provide answer]	

I declare that the particulars given herein above are true, correct and complete to the best of my knowledge, and the documents submitted in support of this form are genuine and obtained legally from the respective issuing authority.

I declare that none of the funds received or to be received by my company will be used for criminal activities, including financing terrorism or money laundering.

By sending this declaration to SPC, I agree that my business and personal information may be used by SPC for due diligence purposes. I also understand and accept that SPC will treat any personal information it receives in connection with my proposal in accordance with its [Privacy Policy](#), and the [Guidelines for handling personal information of bidders and grantees](#).

For the Bidder: *[insert name of the company]*

Signature:

Name of the Bidder's representative: *[insert name of the representative]*

Title: *[insert Title of the representative]*

Date: *[Click or tap to enter a date]*

Annex 4: TECHNICAL PROPOSAL SUBMISSION FORM

INSTRUCTIONS TO BIDDERS

[Insert instructions for bidders to better understand SPC's requirements for their technical proposal.]

The Technical Proposal Submission Form is a table that includes the technical criteria (set out in Part 3) on which bidders will be scored and allows the bidder to respond to them. This table is then used by the technical evaluation committee to score the technical proposals received.

The table below is an example of a format that can be modified. In all cases, the Technical Proposal Form should be based on the evaluation matrix and SPC statement of needs.]

Technical Requirements	
<i>Competency Requirements</i>	<i>Response by Bidder</i>
Organisational Requirements	
<ul style="list-style-type: none"> Bidders shall provide details of two supply contracts that demonstrate their track record in completing supply contracts similar to this Proposal. 	Details for three referees: <ol style="list-style-type: none"> Client Name: Contact Name Contact details: Value Contract: Client Name: Contact Name Contact details: Value Contract:
Training and Support Services	
<ul style="list-style-type: none"> Having the capacity to provide virtual training, and technical support during installation and commissioning 	<i>[Bidder's answer]</i>

<ul style="list-style-type: none"> • Provide a virtual training plan for installation and commissioning <p>Having the necessary support services to assist in trouble shooting, when required</p>						
<p>Risks/Mitigation Measures:</p> <p>Bidder to identify potential risks for the supply and delivery of the materials and fittings, likelihood of these risks and effective measures to mitigate these risks. Please prepare a risk matrix identifying the risks related to the supply chain for this procurement and provide mitigating measures. Please ensure to identify all risks relating to the current COVID situation including border closures.</p>						
<p>Delivery</p> <ul style="list-style-type: none"> • Proper package before delivery • Timeliness of delivery and chronological list of events and/or tasks that would be involved from accepting your tender to successful implementation • Clearance 			<p>[Bidder's answer]</p>			
<p>Replacements and Warranties</p> <ul style="list-style-type: none"> • Ability to replace any of the failed SHS equipment, components and materials during the warranty period. • Ability to liaise with manufacturers on the replacement of any failed SHS equipment, components and materials 			<p>[Bidder's answer]</p>			
<p>Alternative items</p> <ul style="list-style-type: none"> • Quality and assurance of alternative items offered in comparison to the requested item in RFP. 			<p>[Bidder's answer]</p>			
<p>Others Risks and mitigation measures worth mentioning</p>			<p>[Bidder's answer]</p>			
<p>Timelines, Quality Control and Management</p>			<p>Bidders Response</p>			
<p>No</p>	<p>Item Description</p>	<p>Quantity</p>	<p>Availability of item in</p>	<p>Alternative</p>	<p>Details about Quality (brand, durability against environment and origin)</p>	<p>Estimated lifetime</p>

			stock			
1	<p>PV array . The total capacity shall be no less that 60kwp. PC combiner boxes with PV string combiners and DC disconnects. Lightning Arrestors</p>	1 array	[Bidder's answer]			
2	<p>Spare solar panels. Exact replacement for panels, solar array.</p>	12 panels	[Bidder's answer]			
3	<p>Arrays mounting system compatible with the concrete foundations & concrete supports built by YSPSC on flat sites. Total array of 60kWp will be divided into sub-arrays. Shall include the concrete foundation bolts (concrete supports bolts). A complete list of components to be supplied by the supplier will be provided with the bid.</p>	As necessary	[Bidder's answer]			
4	<p>Set of MPPT battery solar charge controllers such as:twelve MPPT - maximum continuous output current 100A - maximum array 6000W</p>	1 set	[Bidder's answer]			

	- grouped into three clusters. Each cluster consisting of four MPPT solar charge controllers providing a total of 400 A charging current. Each MPPT connected to a PV array of 5kWp.					
5	Spare MPPT controllers Exact replacement for controllers	2 units	<i>[Bidder's answer]</i>			
6	Battery banks 2V (nominal) lead-acid cells of no less than 4100 Ah. Paralleling of cells is not permitted. Connecting cables to construct three 48V banks of cells included. Tropical rated electrolyte included. Complete racks and retaining trays included.	72 cells	<i>[Bidder's answer]</i>			
6.b	Spare battery cells. Exact replacement for cells used in battery banks	3 cells	<i>[Bidder's answer]</i>			
6.c	Battery Monitor keeping track of voltage, current, SOC, Ah in/out, providing status of battery to connected devices on the communication	1 spare	<i>[Bidder's answer]</i>			

	network, allowing SOC-based Start & Stop from the AGS.					
7.a	Power inverters Continuous capacity of no less than 61.2kW providing 120Vac each phase to neutral - 208Vac phase to phase at 60Hz. Inverter system will be powered from three 48Vdc battery banks (one for each phase).	1 three phase assembly	<i>[Bidder's answer]</i>			
7.b	Spare inverters. Exact replacement for inverters used in the main three phase installation	2 units	<i>[Bidder's answer]</i>			
8.a	Balance of system components to complete the 3-phase power system. Complete list of components to be supplied shall be included in the offer. MPPT charge controllers, battery banks and inverter system will be housed in the existing YSPSC building, close to the arrays as pictured on photo 2 (E10 – DIAGRAMS and	1 set	<i>[Bidder's answer]</i>			

	<p>PHOTOS).</p> <p>All wiring, connection boxes, hardware, necessary electrical protections, surge arresters, disconnectors and switches, mounting materials and hardware for batteries, inverters, charge controllers and other balance of system components to be installed in the powerhouse and from the arrays to the powerhouse shall be provided by the supplier.</p> <p>Sufficient and adequate cabling of the proper size, length and type, for underground use; Cables (DC & AC) from PV arrays to control room, batteries banks, power distribution panels, boxes, grid connection point, to diesel generators and to switches shall be provided.</p>					
8.b	Power Distribution Panels (PDP) housing	As necessary	<i>[Bidder's answer]</i>			

	the electrical protections AC & DC: AC and DC breakers integrating the inverters, the batteries, and AC input and output.					
8.c	Communication & monitoring device(s) enabling configuration, control, status reporting of devices connected to the network through a web browser user interface	1 set	[Bidder's answer]			
8.d	System Control Panel / Interface	1 set + spare	[Bidder's answer]			
8.e	Power Meters to ensure that power flow is monitored, to enable remote monitoring and diagnostics of the system.	2	[Bidder's answer]			
8.f	Network router / Industrial grade router	1	[Bidder's answer]			
8.g	Cellular modem / Industrial grade modem	1	[Bidder's answer]			
8.h	Bypass device / high current manual changeover switch External main contactor	1 set	[Bidder's answer]			
8.1	Automatic Generator Start (AGS) activating or stopping	1	[Bidder's answer]			

<p>the generator in response to changing power requirements, sharing status information with all devices, monitoring user-programmable parameters, battery voltage, state of charge, grid power</p>					
---	--	--	--	--	--

For the Bidder: *[insert name of the company]*

Signature:

Name of the Bidder's representative: *[insert name of the representative]*

Title: *[insert Title of the representative]*

Date: *[Click or tap to enter a date]*

Annex 5: FINANCIAL PROPOSAL SUBMISSION FORM

1. All costs indicated on the financial proposal should be in CIF inclusive of all applicable taxes.
2. The financial proposal must also include the cost of virtual training to be provided.
3. The format shown below should be used in preparing the price schedule.

NO	ITEM DESCRIPTIONS	QTY	TOTAL	Unit Cost (USD)	Total Cost (USD)
1	PV array with total capacity no less than 60 kWp with PV Combiner Boxes with PV string combiners and DC disconnect. Including Lightning Arresters	1 array			
2	Spare solar panels. Exact replacement for panels, solar array.	12 panels			
3	Arrays mounting system compatible with the concrete foundations & concrete supports built by YSPSC on flat sites.	As necessary			
4	Set of MPPT battery solar charge controllers	1 set			
5	Spare MPPT controllers Exact replacement for controllers	2 units			
6	Battery banks 2V (nominal) lead-acid cells of no less than 4100 Ah with connecting cables.	72 cells			
6.b	Spare battery cells. Exact replacement for cells used in battery banks	3 cells			
6.c	Battery Monitor	As necessary plus 1 spare			
7.a	Power inverters (nine inverters 6800W or six inverters 12000W grouped into three clusters)	1 three phase assembly			
7.b	Spare inverters. Exact replacement for inverters used in the main three phase installation	2 units			

8.a	<p>Balance of system components to complete the 3-phase power system.</p> <p>Complete list of components to be supplied shall be included in the offer inclusive of All wiring, connection boxes, hardware, necessary electrical protections, surge arresters, disconnectors and switches, mounting materials and hardware for batteries, inverters, charge controllers and other balance of system components to be installed in the powerhouse and from the arrays to the powerhouse.</p> <p>Sufficient and adequate cabling of the proper size, length and type, for underground use; Cables (DC & AC) from PV arrays to control room, batteries banks, power distribution panels, boxes, grid connection point, to diesel generators and to switches.</p>	1 set			
8.b	<p>Power Distribution Panels (PDP) housing the electrical protections AC & DC: AC and DC breakers integrating the inverters, the batteries, and AC input and output.</p>	As necessary			
8.c	<p>Communication & monitoring device(s) enabling configuration, control, status reporting of devices connected to the network through a web browser user interface</p>	1 set			
8.d	<p>System Control Panel / Interface</p>	1 set + spare			
8.e	<p>Power Meters to ensure that power flow is monitored, to enable remote monitoring and diagnostics of the system.</p>	2			
8.f	<p>Network router / Industrial grade router</p>	1			
8.g	<p>Cellular modem / Industrial grade modem</p>	1			

8.h	Bypass device / high current manual changeover switch External main contactor	1 set			
8.i	Automatic Generator Start (AGS)	1			
9.	All related training costs				
	Total Cost				
	Freight & Marine Insurance				
	Documentation & Packaging				
	Other Charges (please specify if any)				
	Total CIF (USD)				

For the Bidder: *[insert name of the company]*

Signature:

Name of the Bidder's representative: *[insert name of the representative]*

Title: *[insert Title of the representative]*

Date: *[Click or tap to enter a date]*