

SOUTH PACIFIC COMMISSION

ELEVENTH REGIONAL TECHNICAL MEETING ON FISHERIES
(Noumea, New Caledonia, 5-10 December 1979)

ANCHORED FISH AGGREGATION DEVICES IN HAWAIIAN WATERS

by

Walter M. Matsumoto, Thomas K. Kazama, and Donald C. Aasted
Southwest Fisheries Center
National Marine Fisheries Service, NOAA
Honolulu, Hawaii 96812

October 1979

This working paper was prepared solely for discussions at the South Pacific Commission Eleventh Regional Technical Meeting on Fisheries, Noumea, New Caledonia, 5-10 December 1979 and is subject to revision. Its contents should not be cited without consent of the authors.

INTRODUCTION

The behavior of pelagic fishes to aggregate beneath or near floating objects is being exploited by a number of fisheries. Indonesian fishermen use moored rafts to which palm fronds are attached to attract various clupeids, scombrids, and carangids (Hardenberg, 1950; Soemarto, 1960), the Japanese use moored bamboo rafts to attract dolphin, Coryphaena hippurus (Kojima, 1960, 1966a, 1966b), and Maltese fishermen use anchored cork floats to attract dolphins and pilotfish in the "kannizzati" fishery off Malta (Galea, 1961).

Tunas also have been found to aggregate around floating objects. Japanese pole-and-line fishermen and American live-bait and purse seine fishermen routinely seek out floating logs, masses of drifting seaweed, and other flotsam while fishing for yellowfin tuna, Thunnus albacares, and skipjack tuna, Katsuwonus pelamis (Uda, 1933; Kimura, 1954; McNeely, 1961; Inoue et al., 1963, 1968). Food and Agriculture Organization of the United Nations (FAO) chartered purse seiners working in the Sulu and Celebes Seas also found that successful catches of tunas were almost always made around drifting logs (Chikuni, 1978).

More recently, a method of seining for tunas around large bamboo rafts anchored in calm and extremely deep waters of up to 5,486 m (3,000 fathoms) has been devised and developed in the Philippine tuna fishery (Matsumoto¹). Fishing around these rafts have been so successful that the catch could exceed 100,000 metric tons (MT) in the next year or two, if it has not done so already.

To determine if anchored devices could be maintained in moderate to rough sea conditions and be as effective as those used in calm waters in the Philippines, and to aid the Hawaiian skipjack tuna fishery to increase

¹Matsumoto, W. M. Payao fishing in the Philippines. Manuscr. in prep. Southwest Fisheries Center Honolulu Laboratory, National Marine Fisheries Service, NOAA, Honolulu, HI 96812.

its catch, particularly during the so-called off-season, the National Marine Fisheries Service (NMFS) Honolulu Laboratory (HL) began a program to construct and anchor six fish aggregation devices off the Hawaiian Islands in May 1977, and to monitor the catches around the devices through July 1979. The Pacific Tuna Development Foundation provided financial support for the project with the intention of subsequently funding similar projects in the various Pacific islands, utilizing the knowledge gained from the Hawaiian experiment.

BUOY DESIGN AND METHOD

Background

Studies dealing with the association of fish with various natural and artificial floating objects have been made in the past. Senta (1966) used straw sheaves, straw sheaves tied to bamboo frames, polyvinyl chloride (PVC) strips, straw mats, and artificial seaweed made of palm hair and found no difference among these materials in attracting juvenile fish. Hunter and Mitchell (1968) found that plastic sheets placed horizontally at the surface had greater attraction than those placed vertically and that a tent-shaped configuration was more effective than those horizontally placed. Inoue et al. (1963), obtained data showing that old drift objects were more likely to be accompanied by skipjack tuna, that timber was more successful in attracting skipjack tuna schools than other flotsam, and that timber in the horizontal position was more effective in attracting schools than in the vertical position, but that the catch rate (catch per drift object) of skipjack tuna was slightly better with the timber floating vertically.

The better attributes of both horizontally and vertically floating logs have been incorporated in the Philippine fish aggregation device (Matsumoto, see footnote 1). The device consists of a large bamboo raft, 2.5 x 11 or 12 m, from which two lengths of rope 36 m long are suspended. Palm leaves are attached to the ropes at intervals of 2-3 m. Such rafts have successfully attracted large quantities of tunas and other pelagic fishes.

Types of Devices Used in the Hawaiian Experiment

Two types of fish aggregation devices were used in the Hawaiian experiment. Both types were equipped with fish attractant material suspended from the float, as in the Philippine raft. The attractant material, however, differed from the palm leaves used in the latter, since such palm leaves were not readily available in Hawaii.

The first type was a buoy made of two 208-liter (55-gal) oil drums filled with polyurethane foam and held together in a frame of 7.6 x 7.6 x 0.5-cm (3 x 3 x 3/16 in.) angle iron (Fig. 1) To prevent excessive rotation of the buoy, the angle iron frame was extended below to form a V at the front and rear, to which 2.5 x 10.2-cm (1 x 4-in.) wooden slats were attached. A 13.7-m (45-ft) long drape made of 1.6-cm (5/8-in.) polypropylene rope with a weight at the bottom was hung from the buoy. The drape consisted of 12 lengths of rope hung vertically with cross-members spliced to each at 1.5-m (5-ft) intervals. A pyramid, 0.9 x 1.2 m (3 x 4 ft), at the base and 1.2 m (4 ft) high was built over the drums with a 3.2 x 0.5-cm (1-1/4 x 3/16-in.) angle iron frame and covered over with 0.6-cm (1/4-in.)

Fig. 1

plyboard. The pyramid was painted orange and white in alternate horizontal bands and marked A, B, C, etc., according to U.S. Coast Guard requirements. A compartment to house the battery pack, including a hinged door on the rear panel, was built in the upper half of the pyramid. A radar reflector and a light fixture were mounted 1.8 m (6 ft) above the pyramid on a 2.5-cm (1-in.) galvanized pipe. Details of the buoy and radar reflector are shown in Figures 2 and 3.

Figs. 2, 3

The buoy was initially anchored with a raft, 0.3 x 0.9 x 6.1 m (1 x 3 x 30 ft) made of 3.8-cm (1-1/2-in.) PVC pipes bolted onto metal frames with floats at both ends, which was tied to the buoy with 18 m (10 fathoms) of 1.6-cm (5/8-in.) polypropylene rope. Six to eight coconut palm fronds attached to a 15.2-m (50-ft) length of cable were suspended from the end of the raft. However, the palm fronds were too fragile and required replacements every 2-3 weeks. The raft also was prone to excessive damage by being banged against the buoy by rough seas. Consequently the raft was removed from the buoy and drapes made of polypropylene rope were used to replace the coconut palm fronds.

The second type of device used was a raft, 1.2 x 3.6 m (4 x 12 ft), made of 5.1 x 15.2-cm (2 x 6-in.) wooden planks bolted top and bottom to four 10.2 x 10.2-cm (4 x 4-in.) crosspieces. The spaces between the top and bottom layers were filled with polyurethane foam. A pyramid and radar reflector-light pole similar to that used on the buoy were mounted on the raft. A drape made of 2.5-cm (1-in.) mesh netting, with 45.7-cm (18-in.) long rope strands attached to it, was hung from the raft (Fig. 4).

Fig. 4

Anchor and Anchoring Method

A 544.3-kg (1,200-lb) block of concrete was used as the anchor. At one of the six sites where the buoys and rafts were anchored, the currents were strong enough to drag the anchor 2.5 miles over flat bottom.

The anchor line consisted of 1.6-cm (5/8-in.) polypropylene rope with 15.2-m (50-ft) lengths of 1.3-cm (1/2-in.) chain at the top and the bottom. The scope of the line was between 1.6 and 1.7:1. Because polypropylene rope is buoyant, a chain link weight was added to the upper one-fourth to one-third of the anchor line to keep the line from reaching the surface during slack tide. The position of the weight, of course, varied from one buoy to the next, depending upon the length of the line and depth of the site selected for anchoring.

The simplest method was followed in anchoring the devices. The buoy was first set on the water, then the anchor line was payed out, and the anchor was released last in a free fall to the bottom.

BUOY SITES

Fig. 5

Four buoy-type fish aggregation devices were initially anchored south of Oahu and southwest of Lanai (Fig. 5) on 9 and 10 May 1977. Buoy A was anchored at a depth of 563 m (308 fathoms), 2 miles from the 914- to 1,829-m (500- to 1,000-fathom) ledge; buoy B at a depth of 443 m (242 fathoms), 1 mile off Penguin Bank, and buoy C at a depth of 450 m (246 fathoms), 1 mile off the tip of Penguin Bank, and buoy D at a depth of 631 m (345 fathoms), 1.1 mile from the 914- to 1,829-m (500- to 1,000-fathom) ledge. The first three buoys were exposed to the northeast trade with winds of 15 to 25 knots and seas as high as 1.2 to

3.6 m (4 to 12 ft), while the last was located in relatively calm waters in the lee of Maui, although at times the seas there could rise to 2.4 m. Buoy A was 16 miles from Kewalo Basin, buoys B and C were 17 and 27 miles, respectively, from Kewalo Basin and buoy D was 10.5 miles from Palaoa Point, Lanai and approximately 65 miles from Kewalo Basin. Buoys B and C were placed off the edge of Penguin Bank to determine what effect the shallow bank (generally 46 to 64 m (25 to 35 fathoms)) had upon the buoys, and buoys A and D were placed near the 914- to 1,829-m (500- to 1,000-fathom) ledge on the basis of reports by trolling boat operators that the best catches of tunas occurred near the 1,829-m (1,000-fathom) drop-off.

Subsequently, on 22 March 1978, two raft-type devices (hereafter called buoys) were anchored off Kona, Hawaii. The first, buoy F, was placed 4.5 miles west of Kaiwi Point at a depth of 2,286 m (1,250 fathoms), and the second, buoy G, was placed 6 miles offshore, 8 miles north-northwest of Keahole Point, at a depth of 402 m (220 fathoms) and 3.5 miles from the 1,829-m (1,000-fathom) ledge (Fig. 5). Both sites were in proven fishing areas for tunas and billfishes.

MONITORING OF BUOYS AND CATCHES

A monitoring and buoy maintaining schedule of one visit per month to each of the four buoys off Oahu and Lanai was set up, with more frequent visits planned at the height of the skipjack tuna season. However, due to prolonged periods of rough sea conditions at the buoy sites and the unavailability of the chartered vessel at critical periods, we were not able to follow the planned schedule.

On all monitoring trips troll fishing was done at the buoy site, and on runs between buoys, all bird and fish school sightings and sightings of scattered birds were noted, and the immediate area around the buoys was scanned with the depth recorder to determine the presence of fish.

Catch data from commercial bait boats visiting the buoys were obtained through interviews and catch forms supplied to all 12 boats comprising the bait boat fleet in January 1978. Catches made during the first 3 months were obtained entirely through interviews. Because of difficulties encountered in interviewing all boat operators on a daily basis and the reluctance of some to disclose where catches were made, the recorded catches and visits to the buoys are considered minimal. The vessels began filling out catch forms in early April, and as the catches around the buoys improved, the reports of visits and catches at the buoys increased sharply near the end of the month and continued through May. Despite this improvement, nearly a third of the fleet neglected to report all trips made to the buoys.

Reports of catches slackened in the latter half of 1978 and none was turned in until May 1979. Although there were extenuating circumstances, such as the presence of large skipjack tuna elsewhere in the fishing area and the losses of buoy A in January and buoy D in March 1979, we learned that occasional visits were made to these buoys before they were lost.

Monitoring trolling boats was even more difficult. It was not possible to monitor visits to the buoys made by all trolling boats since the buoys attracted boats based at outlying harbors and numerous weekend trailer-boat fishermen, who launched their boats from scattered

points. Thus, the collecting of catch and other data was limited to boats based at Kewalo Basin. Even this presented problems because some of the charter boats fished irregularly, going out only when chartered. Consequently, only 15-25 boats were monitored on a near regular basis.

Initial attempts to have the fishermen fill out catch reports were not successful. Therefore, the collecting of fishing data had to be done through interviews with the boat operators.

BUOY PERFORMANCE AND PROBLEMS

All four buoys, A, B, C, and D, initially anchored on 9 May 1977 broke free from their moorings in July, after 7 to 10 weeks. The cause of the mooring line failure was traced to galvanic reaction between the copper fittings and a length of steel cable which had been inserted into the anchor line. All four buoys were reinstalled between August and October 1977 without the cable section and the buoy designation, B was changed to E. A miscalculation in the positioning of buoy E resulted in its loss in December. The buoy was placed too close (1/4 mile) to the edge of Penguin Bank where the bottom rose nearly vertically from a depth of 366 to 46 m (200 to 25 fathoms) and the anchor line could not clear the ledge as the buoy swung over the bank. This buoy was replaced in March 1978.

Since their renewal, the buoys remained in position for a long enough period to prove their effectiveness in attracting fish. Buoys A, E, and D lasted for 16 months, and C remained in position for 20 months. Buoy A was lost in late December 1978, and buoy D in late

February 1979 due to prolonged periods of high wind and sea conditions. Buoys C and E which weathered the storms were finally lost in June and August 1979, respectively. Buoy A was replaced on 31 March, but the others were not because of the closeness to the scheduled termination date of the project (September 1979).

Buoys F and G off Kona, Hawaii were not part of the original buoy program. Consequently, wooden rafts that were available from a prior experiment were used instead of the steel-drum buoys. The rafts were installed on 22 March 1978 and remained operative until January 1979 (a period of 10 months) when they broke apart during the same December-February series of storms that caused the loss of buoys A and D. Buoy F was subsequently replaced by a drum-type buoy on 1 April 1979.

In addition to buoy losses, there was one other problem: vandalism. The radar reflectors and battery compartments on four of the six buoys were shot at with hand guns and were riddled with bullet holes made by hand guns. On two occasions, bullets were found imbedded in the batteries, leading to light failures.

RESULTS

Pole-and-Line Fishing

Although the buoys were deployed in early May, it was not until late fall that modifications to the buoys were completed and the original buoys which had been lost after the first 2-1/2 months were replaced. The timing of the initial deployment coincided with the start of the skipjack tuna pole-and-line fishing season and the bait boats did

not make any serious attempt to fish around the buoys until late December. Visits to the buoys were not reported, as the boats fishing the buoys initially tried to keep their catches from influencing other boats to visit the buoys. We were able to track down at least three catches of over 4.5 MT (10,000 lb) at buoys A and D and one unconfirmed catch of 9.1 MT (20,000 lb) near buoy A in late December.

The number of visits by these and other boats and the reporting of catches improved with time, as the effectiveness of the buoys became known throughout the fleet. The number of known visits increased from a low of 3 in December 1977 to 79 in May 1978, representing 2.4 and 46.2 percent, respectively, of the monthly fishing trips made by the fleet. The ratio of buoy visits to total monthly trips peaked in April when over 53 percent of buoy trips were recorded (Table 1).

The catches around the buoys also increased, correspondingly, from 15.9 MT (35,200 lb) in December 1977 to 192.7 MT (424,897 lb) in April and 193.5 MT (426,515 lb) in May 1978. At the height of fishing around the buoys in April and May, there were 23 catches of over 4.5 MT (10,000 lb), 2 of over 9.1 MT (20,000 lb), and 2 of over 13.6 MT (30,000 lb). One boat reported catching nearly 27.2 MT (60,000 lb) in 3 days of fishing during a 1-week period.

The monthly buoy catches and cannery landings from December 1977 through December 1978 are shown in Figure 6. Both visits and catches decreased drastically in June and remained low throughout the remainder of the year. The decrease in visits was again due to the commencement of the regular fishing season which drew the boats away from the crowded

Table 1

Fig. 6

buoy areas, where at times, 30 or more boats of all types could be seen fishing around a single buoy. The reduced visits to the buoys during the fishing season was influenced also by economic reasons. The large, >6.8 kg (>15 lb), and medium, 4.1-6.8 kg (9-15 lb), fish command a higher price than the small, 1.8-4.1 kg (4-9 lb), and extra-small, <1.4-1.8 kg (<3-4 lb), fish, and fish in the latter two size categories dominated the aggregations around the buoys, although schools of medium fish were often taken there also.

The pattern of visits and catches in 1979 did not follow that of the previous year for several reasons. First, the December-February period was beset with inclement weather with gale force winds that reduced fishing activity; second, the presence of large and medium skipjack tuna in the fishery in late fall and winter months had kept the boats from returning to the buoys; and third, the loss of buoy A in January and the shifting of buoy D in February and its eventual loss in March, eliminated the main sources of attractants for tunas. By the time buoy A was replaced in April and the 1-month period it required to become effective in attracting fish had gone by, the regular fishing season for skipjack tuna was already at hand. This resulted in minimal visits by the fishing fleet in 1979.

The catch at the different buoys varied considerably. Both buoys A and D, which were anchored in deep water and near the 914- to 1,829-m (500- to 1,000-fathom) ledge, were particularly successful in attracting tunas. They commanded 93.9 percent of all buoy visits in 1978 and 90.1 percent of the catches made at the buoys. Buoy C, anchored near

the edge of Penguin Bank and 6 miles away from the 914- to 1,829-m (500- to 1,000-fathom) ledge, was only moderately successful. Most of the catches there were made during a span of 1 to 2 weeks in April, as fishing diminished at buoy A and increased at buoy D. Buoy E, anchored 15 miles away from the 914- to 1,829-m (500- to 1,000-fathom) ledge, fared even worse as only one visit to it was reported. Both buoys E and C received little attention from the pole-and-line boats since the buoys were located too close to the relatively shallow Penguin Bank, where schools of tunas are seen only occasionally. The area, however, is noted for other species such as mahimahi and wahoo (see trolling results).

Troll Fishing

Table 2

Table 2 lists the visits and catches obtained from interviews with boat operators. Only visits to three buoys are included in the table because the fourth buoy, D, was beyond the normal 1-day range of charter boats. Visits to the buoys remained generally low during the last half of 1977 due to the loss of all three buoys in July and August, and the subsequent waiting period of at least a month before the replaced buoys became effective in accumulating fish.

The low visits to the buoys in November and the lack of data in December were due to the absence of project personnel during that period. Owing to the difficulty in contacting all boats and to the reluctance of some boat operators to divulge their catches, the reported visits and catches are greatly understated. Interviews and reports of catches improved from April 1978 when large catches by both trollers

and bait boats at buoy A created a mood of optimism that resulted in enthusiastic reporting of catches among the boat operators. The reduced visits to the buoys during the summer, June through September, were largely due to heavy summer runs of large yellowfin tuna off the coast of Waianae which lured most of the charter boats away from the buoy area.

During the 26 months of buoy fishing by trollers, buoy A was visited most often (51.0 percent) and recorded the most catches (60.7 percent). During the period April through June 1978, buoy A accounted for nearly 70 percent of the year's catch as a result of the accumulation of tunas which also attracted marlins and spearfish, the primary targets of the charter boats.

Buoys B and C were visited less often (26.4 and 22.6 percent, respectively), however several boats that preferred trolling for mahimahi made regular visits to these buoys. Although buoys B and C were not productive of tunas, they were ideally placed to attract mahimahi from the nearby Penguin Bank. During 1978 the catch rate of mahimahi at these two buoys was 2.42 fish per visit as compared with 0.83 fish per visit at buoy A. In 1979 the difference was even greater, 1.73 fish per visit at buoys B and C versus 0.48 at buoy A.

Fig. 7 The species composition of fish taken at the buoys presents an interesting picture (Fig. 7). Despite the heavy fishing for tunas at buoy A, the mahimahi catch was the highest in all 3 years. The absence of buoy A during the first 3 months in 1979 definitely affected the tuna catch total, but if 1978 is a good example, the mahimahi probably would still not have been replaced as the principal species taken. It should be noted

here that although catches of mahimahi were reported most frequently, it was not the dominant species in terms of number, as seen from the massive catches of skipjack tuna by the bait boats in 1978.

Heavy activity of trolling boats around the buoys usually began about 3 to 4 weeks after the buoys had been deployed. Prior to this time, one or two boats would make occasional visits to the buoys to inspect the buildup of fish around the buoys. As activity around the buoys picked up, fishing at times became hectic. During the second week in April 1978, when the area around buoy A was teeming with large schools of skipjack tuna and birds in the hundreds were seen everywhere from the buoy out to a radius of 1-1/2 or 2 miles, no less than 15 trollers were seen fishing within 3 miles of the buoy. During this period one troller reported a catch of 50 skipjack tuna weighing 4.1-4.5 kg (9-10 lb) each, a second reported 80 skipjack tuna, and a third, 25 skipjack tuna and a 113.4-kg (250-lb) blue marlin, all on the same day.

Occasional reports from Maui indicated similar fishing activity around buoy D where individual boat catches of 136.1-317.5 kg (300-700 lb) of skipjack and yellowfin tunas and 45.4 kg (100 lb) of mahimahi per weekend were commonly made in April 1978. One boat from Lanai reported catching 226.8-453.6 kg (500-1,000 lb) of yellowfin tuna on each visit to the buoy, releasing all the 3.6-4.5 kg (8-10 lb) skipjack tuna caught to reserve boat space for the larger 13.6-22.7 (30-50 lb) yellowfin tuna.

Other reports from Kona, Hawaii indicate the effectiveness of the buoys. Buoy F was anchored in May at a depth of 2,286 m (1,250 fathoms) at the edge of an outstanding fishing area. By July, it was teeming with 1.4-4.5 kg (3-10 lb) skipjack and yellowfin tunas, and with marlin. The trollers could run to the buoy and in 10-15 minutes pick up small skipjack tuna, which they used as bait for marlin fishing, and begin fishing for marlin immediately instead of losing nearly half-a-day or more, as they were accustomed to, before the buoys were installed. In the height of the summer marlin run, some trollers which took advantage of easy catches of bait-size skipjack tuna around the buoy were reporting catches of 10-11 marlins in 10 days, while others were reporting catches of 3 and 4 marlins a day.

Other Types of Fishing

The buoys off Kona, Hawaii also attracted many commercial skiff fishermen using the "drop stone" method to fish for yellowfin tuna. In this type of fishing, a large 25.4-30.5 cm (10-12 in.) long mackerel scad is used as bait. The bait is laid on a smooth stone weighing about 0.9 kg (2 lb) together with a package of chopped up mackerel scad wrapped in ti leaves and both bait and chum package are bound to the stone by a few turns of the mainline, and secured by a slip knot. The stone is lowered 55 to 110 m (30 to 60 fathoms) and is jerked free to expose the bait and chum. Normally, this type of fishing is done at night for yellowfin tuna weighing 45.4-113.4 kg (100-250 lb) or more. Because of the buoys, however, these fishermen were able to fish for large porpoise-associated yellowfin tuna during daylight.

This type of fishing is done by positioning the skiff in the path of porpoise herds, which circled the buoy at a distance of 3 to 5 miles.

The lines are set to catch the yellowfin tuna accompanying the porpoise as the porpoise herds approach the skiff. Prior to the placement of the buoys, the porpoise herds were known to move out of the area in a day or so but now they tended to remain in the area for longer periods enabling these fishermen to fish on a daily basis.

One report in June 1978 indicated that up to 50 boats fishing off buoy G brought in 15.9 MT (35,000 lb) of yellowfin tuna and marlin on one weekend. The "drop stone" skiffs reportedly averaged three to four yellowfin tuna per day in this period.

DISCUSSION

The daily catch records during April and May 1978 provided interesting information about the fish aggregations attracted to the buoys. First, the record of consecutive days successfully fished at a buoy gives a rough idea of the fish-holding quality of the buoy. During this period, fish were caught at buoy A on 2, 3, 5, and 10 successive-day periods. The longest fish-holding period consisted of 2 successful days, a blank day, followed by 10 successful days, a blank day, and by 2 more successful days. At buoy D fish were caught on 2, 4, and 10 successive days, the last 2 separated by a blank day. It cannot be stated definitely whether the single blank day between periods of consecutive successful days was really devoid of fish or whether the boats fishing that day at the buoys failed to report the catches. Because we know that reporting of catches was not followed diligently by all boats, the latter would seem more likely. Thus, we can say that the tuna schools remained in the buoy area for periods of up to 2 weeks at a time.

Second, on 12 days during the 2-month period, three to five boats reported catches from the same buoy, which suggested that more than one fish school may have been present around the buoy at the same time. Interviews with trolling boat operators and our own observations of bait boat activity around the buoys support this, as on several occasions we noted two or three bait boats fishing on opposite sides of a buoy at distances of up to a mile from the buoy. Whether these were schools that had broken away from a single large school was not determined, but this was possible.

Third, the total aggregate of fish caught over consecutive days could represent fish from a single school. At buoy A, the catches of 3, 5, and 16 consecutive days were 35.9 MT (79,084 lb), 22.0 MT (48,455 lb), and 63.0 MT (138,689 lb), respectively. At buoy D, the 15-day catch was 155.7 MT (342,717 lb). These totals are comparable with the purse seine catches made in the Philippine payao (raft) fishery (Matsumoto, see footnote 1), where catches of 20 to 40 MT per set from individual rafts are quite common and catches of up to 200 MT are made occasionally.

It is not possible to determine accurately what the total catch might have been without the buoys in 1978, nor to what extent the buoys had increased the catch during the off-season winter months, because both monthly and annual catches in the fishery fluctuate widely from season to season. There is no question, however, that the buoys were a boon to the pole-and-line fishermen. Interviews with fishing boat skippers revealed:

1) That the buoys greatly reduced scouting time and time lost in the pursuit of distant schools, since the schools tended to remain in the vicinity of the buoys.

2) That they could head directly to the buoys and be assured of some catch (a catch as small as 453.6 kg (1,000 lb) is sufficient to pay for a week's supply of fuel for some boats).

3) That they could risk making trips with (a) inferior bait species, (b) baitfish in slightly weakened condition, or (c) a bait supply far less than that required for a regular trip. The need for less bait and the proximity of buoy A to Kewalo Basin have enabled some boats to fish 5 or 6 days a week, where previously they would require 3 to 4 days to catch bait. During April 1978, at the height of activity at the buoys, one boat had fished on 8 out of 9 days.

The buoy test, which was aimed primarily to aid the skipjack tuna fishery, resulted in two important side benefits. One was the heavy use of the buoys by trolling boats. Many of the trollers, while engaging in sport or recreational fishing, nevertheless, sell their catch to fish markets. Others fish strictly on a commercial basis. The combined catches of these boats could add significantly to the State of Hawaii's total fish production. Interviews with both charter and commercial trolling boat operators indicated that the buoys greatly reduced the number of zero-catch days.

The other was the utilization of the buoys by the "drop stone" commercial fishermen. This method of fishing is normally done at night, but in Kona, the presence of the buoys made it possible for these

fishermen to operate during the day also. This type of fishing is also done off Hilo, Hawaii where squid is used as the principal bait, supplemented by mackerel scad, and is known as the "ika-sibi" fishery (Yuen, in press). The term "ika-sibi," of Japanese origin, literally translates to "squid tuna" and was coined to describe the Hilo-Kona-based fishery. The fishery, which began in 1973, shows promise of becoming an important segment of Hawaiian fisheries. The catch, consisting of bigeye and yellowfin tunas and albacore, increased from 89.0 MT in 1973 to 154.6 MT in 1975. This fishery could be bolstered greatly by the use of fish aggregating buoys.

LITERATURE CITED

CHIKUNI, S.

1978. Report on fishing for tuna in Philippine waters by FAO chartered purse-seiner. Part I. Exploratory fishing and biological features of resources. FAO/UNDP South China Sea Fisheries Development and Coordinating Programme, SCS/78/WP/74: 1-44.

GALEA, J. A.

1961. The "kannizzati" fishery. FAO Gen. Fish. Council. Mediterr. Proceedings and Technical Papers 6. Tech. Pap. 7:85-91.

HARDENBERG, J. D. F.

1950. Development of pelagic fisheries. Indo-Pac. Fish. Council. Proc. 1st Meet., Sect. 4:138-143.

HUNTER, J. R., and C. T. MITCHELL.

1968. Field experiments on the attraction of pelagic fish to floating objects. J. Cons. 31:427-434.

INOUE, M., R. AMANO, and Y. IWASAKI.

1963. Studies on environments alluring skipjack and other tunas. I. On the oceanographical condition of Japan adjacent waters and the drifting substances accompanied by skipjack and other tunas. [In Jpn., Engl. summ.] Rep. Fish. Res. Lab., Tokai Univ. 1(1):12-23.

INOUE, M., R. AMANO, Y. IWASAKI, and M. YAMAUTI.

1968. Studies on environments alluring skipjack and other tunas. II. On the driftwoods accompanied by skipjack and tunas. Bull. Jpn. Soc. Sci. Fish. 34:283-287.

KIMURA, K.

1954. Analysis of skipjack (Katsuwonus pelamis) shoals in the waters of "Tohoku Kaiku" by its association with other animals and objects based on the records by fishing boats. [In Jpn, Engl. synop.] Bull. Tohoku Reg. Fish. Res. Lab. (3):1-87.

KOJIMA, S.

1960. Fishing for dolphins in the western part of the Japan Sea--
V. Species of fishes attracted to bamboo rafts. [In Jpn, Engl. summ.] Bull. Jpn. Soc. Sci. Fish. 26:379-382.

- 1966a. Studies on fishing conditions of the dolphin, Coryphaena hippurus, in the western regions of the Sea of Japan--XI. [In Jpn., Engl. summ.] Bull. Jpn. Soc. Sci. Fish. 32:647-651.

- 1966b. Studies on fishing conditions of the dolphin, Coryphaena hippurus, in the western regions of the Sea of Japan--XII. The size of a dolphin school. [In Jpn., Engl. summ.] Bull. Jpn. Soc. Sci. Fish. 32:652-654.

McNEELY, R. L.

1961. The purse seine revolution in tuna fishing. Pac. Fish. 59(7):27-58.

SENTA, T.

1966. Experimental studies on the significance of drifting seaweeds for juvenile fishes--I. Experiments with artificial drifting seaweeds. Bull. Jpn. Soc. Sci. Fish. 32:639-642.

SOEMARTO.

1960. Fish behaviour with special reference to pelagic shoaling species: Lajang (Decapterus spp.). Indo-Pac. Fish. Council. Proc., 8 Sess., Sect. 3:89-93.

UDA, M.

1933. Types of skipjack schools and their fishing qualities. [In Jpn.] Bull. Jpn. Soc. Sci. Fish. 2:107-111. (Engl. transl., In W. G. Van Campen, 1952, Five Japanese papers on skipjack. U.S. Fish Wildl. Serv., Spec. Sci. Rep. Fish. 83:68-78.)

YUEN, H. S. H.

In press. A night handline fishery for tunas in Hawaii. Mar. Fish. Rev.

Table 1.--Monthly catches of skipjack tuna from buoy areas (in pounds).

Year Month	Buoy								Totals		Catch per visit	Cannery landings	No. of trips	Catch per trip	Buoy visits as % of total trips	Buoy catch as % of cannery landings
	A		E		C		D		Catch	Visits						
	Catch	Visits	Catch	Visits	Catch	Visits	Catch	Visits								
<u>1977</u>																
Dec.	10,000	1	--	--	--	--	25,200	2	35,200	3	11,733.3	226,622	126	1,798.6	2.4	15.5
<u>1978</u>																
Jan.	9,000	2	--	--	18,600	3	13,938	4	41,538	9	4,615.3	410,210	160	2,563.8	5.6	10.1
Feb.	7,849	7	--	--	1,396	2	40,091	20	49,336	29	1,701.2	143,522	111	1,292.9	26.1	34.4
Mar.	9,718	6	--	--	--	--	22,872	14	32,590	20	1,629.5	142,646	69	2,067.3	29.0	22.8
Apr.	86,738	14	5,110	1	88,734	9	244,315	34	424,897	58	7,325.8	727,933	109	6,678.3	53.2	58.4
May	203,675	47	--	--	--	--	222,840	32	426,515	79	5,398.9	996,312	171	5,826.4	46.2	42.8
June	31,500	7	--	--	--	--	--	--	31,500	7	4,500.0	909,456	183	4,969.7	3.8	3.5
July	28,109	9	--	--	--	--	--	--	28,109	9	3,123.2	869,491	166	5,237.9	5.4	3.2
Aug.	--	--	--	--	--	--	23,170	5	23,170	5	4,634.0	571,981	125	4,575.8	4.0	4.1
Sept.	--	--	--	--	--	--	30,725	9	30,725	9	3,413.9	251,363	80	3,142.0	11.2	12.2
Oct.	--	--	--	--	--	--	22,882	9	22,882	9	2,542.4	341,885	97	3,524.6	9.3	6.7
Nov.	--	--	--	--	--	--	34,162	12	34,162	12	2,846.8	471,969	107	4,410.9	11.2	7.2
Dec.	--	--	--	--	--	--	--	--	--	--	--	218,450	76	2,874.3	--	--
Totals	376,589	92	5,110	1	108,730	14	654,995	139	1,145,424	246	41,731.0	6,055,218	1,454	47,163.9	205.0	205.4

Table 1.--Continued.

Year Month	Buoy								Totals		Catch per visit	Cannery landings	No. of trips	Catch per trip	Buoy visits as % of total trips	Buoy catch as % of cannery landings
	A		E		C		D		Catch	Visits						
	Catch	Visits	Catch	Visits	Catch	Visits	Catch	Visits								
1979																
Jan.	(Buoy lost)		--	--	--	--	--	--	--	--		113,050	47	2,405.3	--	--
Feb.	↓		--	--	--	--	--	--	--	--		220,540	74	2,980.3	--	--
Mar.			--	--	--	--		(Buoy lost)	--	--		258,607	74	3,494.7	--	--
Apr.	(Buoy replaced)		--	--	--	--			--	--		280,668	109	2,574.9	--	--
May	10,500	5	--	--	--	--			10,500	5	2,100.0	1,045,667	176	5,941.3	2.8	1.0
June	18,841	5	--	--		(Buoy lost)			18,841	5	3,768.2	827,293	187	4,424.0	2.7	2.3
July	4,200	3	--	--					4,200	3	1,400.0	1,012,239	184	5,501.3	1.6	0.4
Aug.	(Buoy lost)		(Buoy lost)						--	--	--	--	--	--	--	--
Totals	33,541	13	--	--	--	--	--	--	33,541	13	7,268.2	3,758,064	851	27,321.8	7.1	3.7

Table 2.--Fish caught by trolling boats based at Kewalo Basin.

Year	Buoy	A		B/E			C			All buoys			
		Month	Catch		Visits	Catch		Visits	Catch		Visits	Catch	
Visits	No. of fish		Wt.	No. of fish		Wt.	No. of fish		Wt.	No. of fish		Wt.	
<u>1977</u>													
May		(Buoys anchored on 9 May)											
June	8	18	475	3	0	0	4	1	5	15	19	480	1.26
July	--	--	--	5	57	335	1	11	55	6	68	390	11.33
Aug.	2	0	0	--	--	--	--	--	--	2	0	0	0.00
Sept.	2	4	25	--	--	--	--	--	--	2	4	25	2.00
Oct.	12	18	187	7	22	170	1	0	0	20	40	357	2.00
Nov.	2	1	10	2	3	40	1	0	0	5	4	50	0.80
Dec.		(No data)											
Totals	26	41	697	17	82	545	7	12	60	50	135	1,302	2.7
<u>1978</u>													
Jan.	9	64	351	--	--	--	7	49	415	16	113	766	7.06
Feb.	9	29	216	--	--	--	7	3	26	16	32	242	2.00
Mar.	6	6	272	--	--	--	5	3	50	11	9	322	0.82
Apr.	14	236	2,499	3	5	84	6	38	395	23	279	2,978	12.13
May	19	294	4,083	8	23	363	9	129	992	36	446	5,438	12.39
June	6	35	431	4	32	452	4	33	591	14	100	1,474	7.14
July	7	45	1,340	1	2	16	2	4	42	10	51	1,398	5.10
Aug.	11	14	327	1	7	42	5	17	148	17	38	517	2.24
Sept.	5	17	1,001	1	2	38	--	--	--	6	19	1,039	3.17
Oct.	31	26	953	8	9	152	12	6	105	51	41	1,210	0.80
Nov.	37	33	210	8	10	135	6	6	165	51	49	510	0.96
Dec.	3	10	250	8	1	6	6	2	15	17	13	271	0.76
Totals	157	809	11,933	42	91	1,288	69	290	2,944	268	1,190	16,165	4.44

Table 2.--Continued.

Year	Buoy	A			B/E			C			All buoys		
		Catch			Catch			Catch			Catch		
Month	Visits	No. of fish	Wt.	Visits	No. of fish	Wt.	Visits	No. of fish	Wt.	Visits	No. of fish	Wt.	Catch/visit
<u>1979</u>													
Jan.	--	--	--	11	18	189	10	21	205	21	39	394	1.85
Feb.	--	--	--	37	69	1,705	15	18	322	52	87	2,027	1.67
Mar.	--	--	--	16	15	180	12	4	48	28	19	228	0.68
Apr.	10	4	51	7	11	144	8	14	171	25	29	366	1.16
May	59	189	2,582	15	36	594	15	61	2,076	89	286	5,252	3.21
June	27	136	1,551	6	22	434	1	3	60	34	161	2,045	4.74
July	30	45	1,315	9	25	257	--	--	--	39	70	1,572	1.79
Totals	126	374	5,499	101	196	3,503	61	121	2,882	288	691	11,884	2.40
Totals for entire period													
	309	1,224	18,129	160	369	5,336	137	423	5,886	606	2,016	29,351	3.33
Percent of total for all buoys for entire period													
	51.0	60.7	61.8	26.4	18.3	18.2	22.6	21.0	20.0				

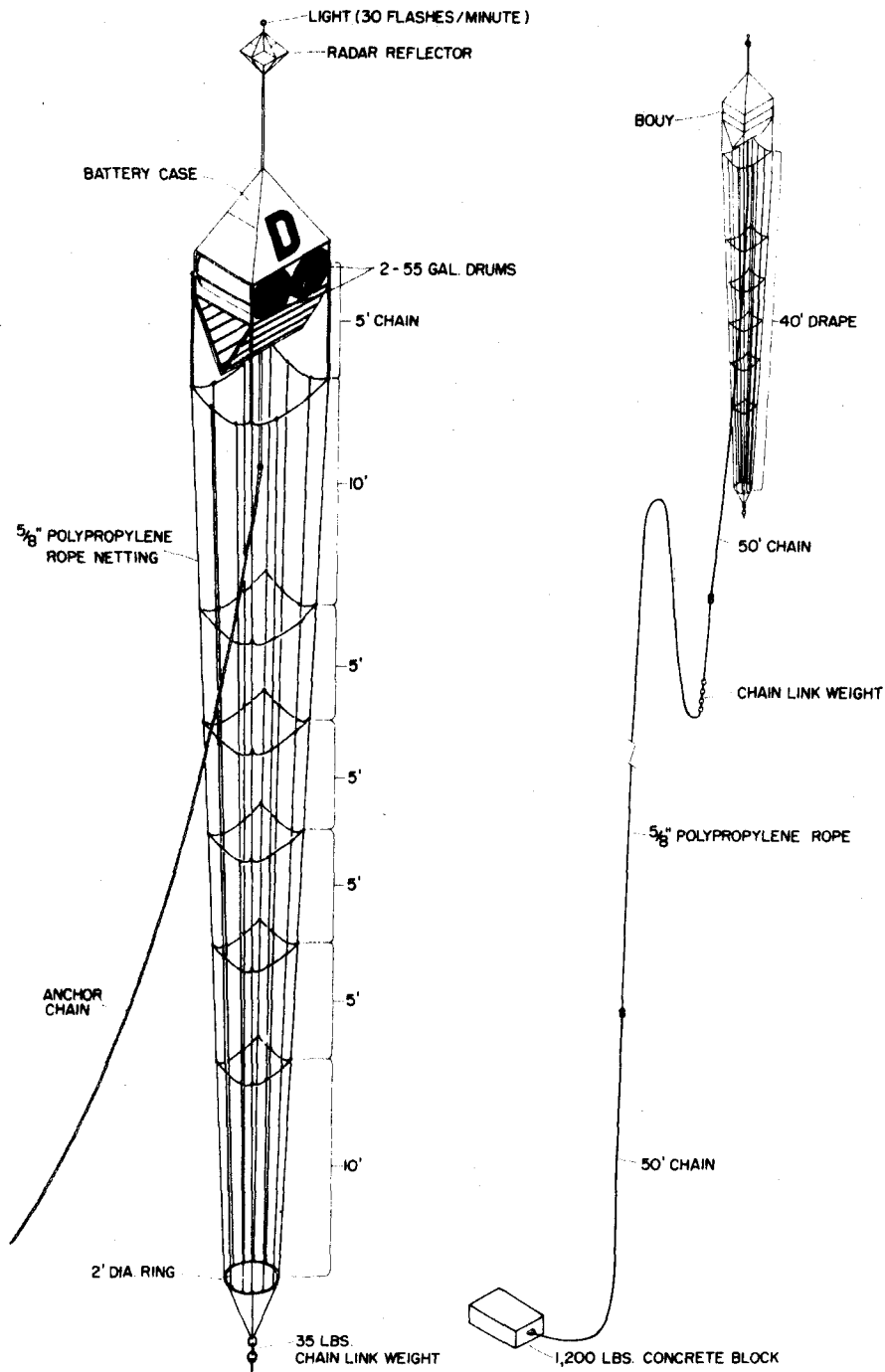

Figure 1.--Fish aggregating device, buoy type.

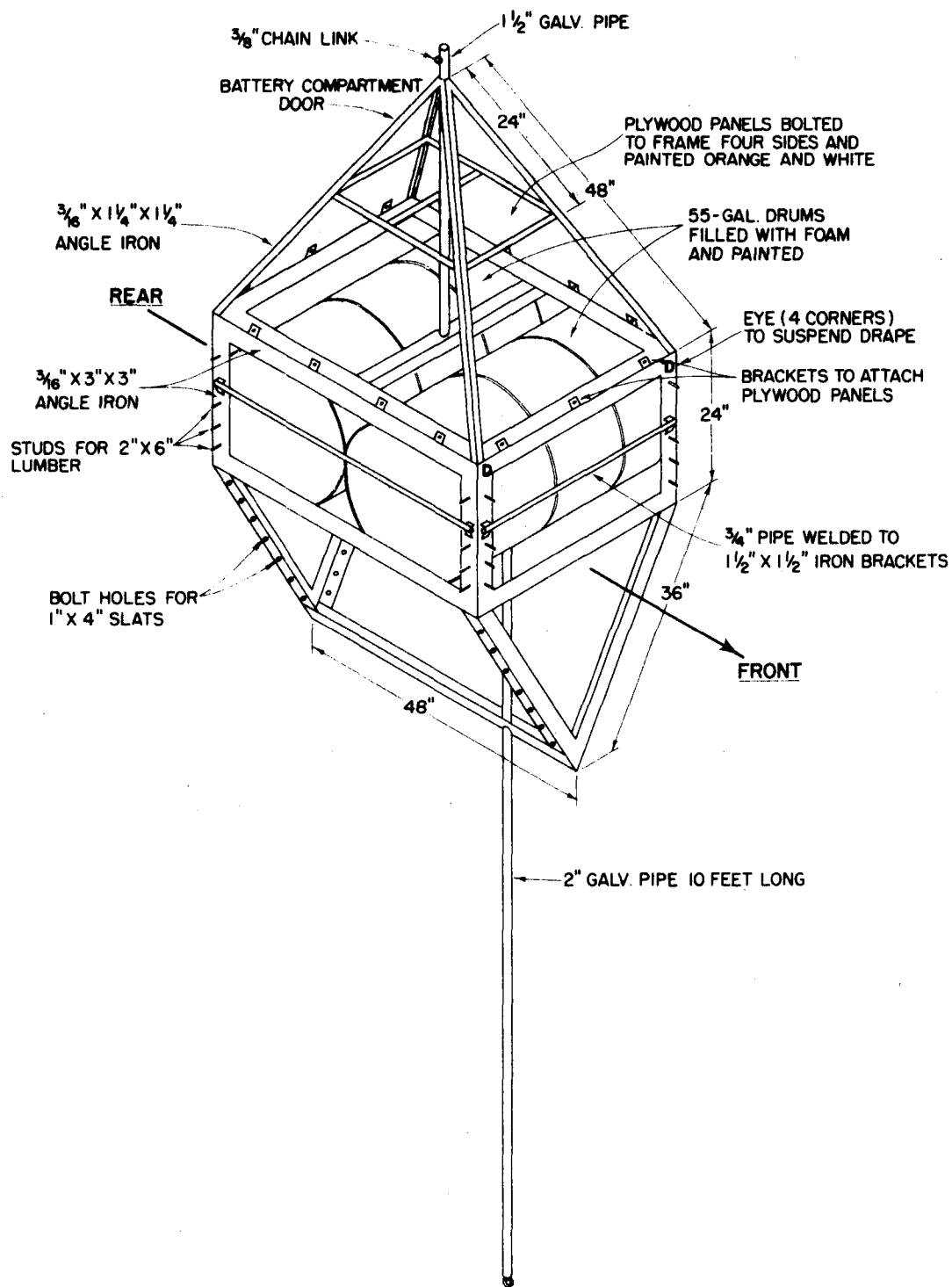

Figure 2.--Details of buoy.

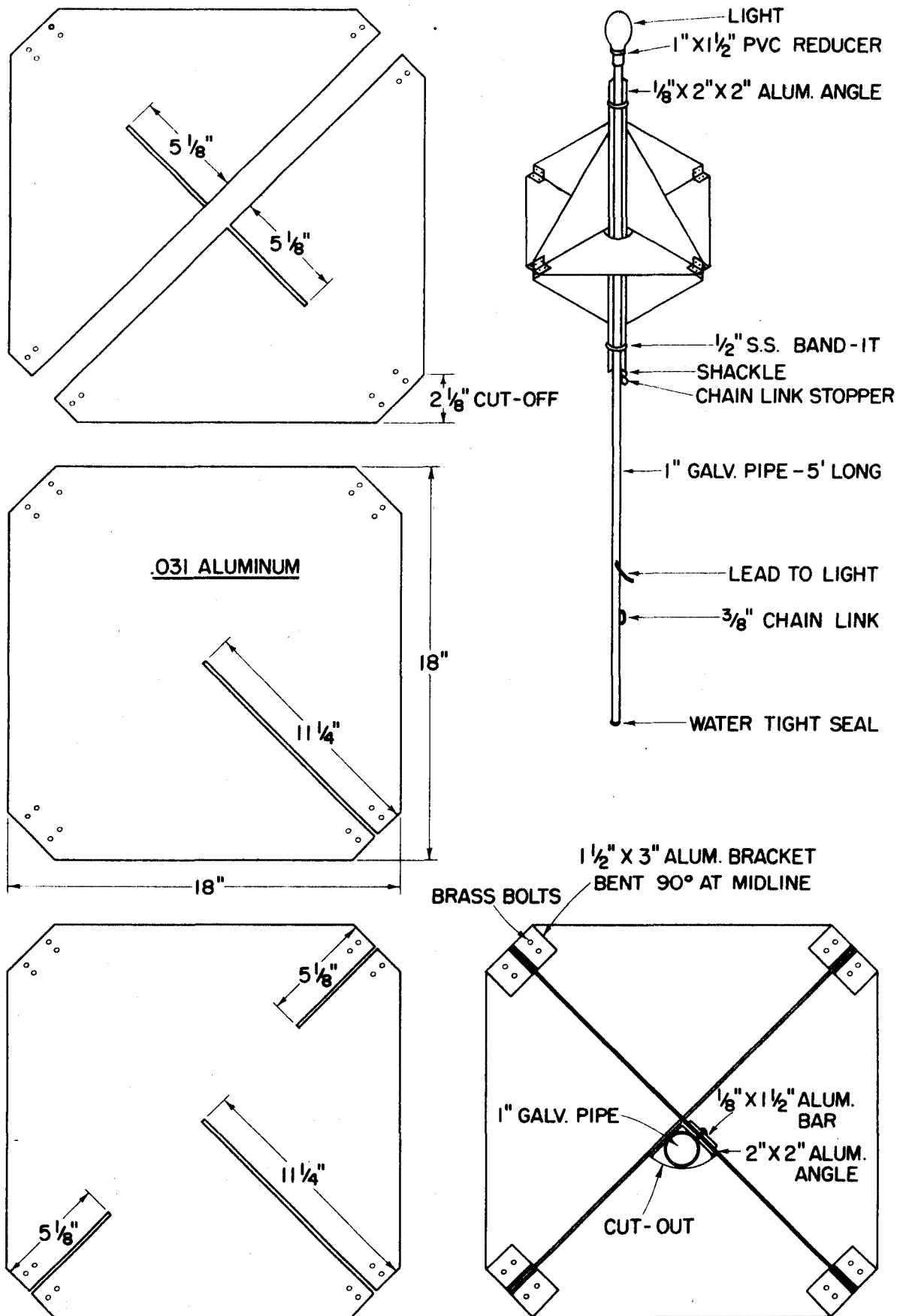

Figure 3.--Details of radar reflector.

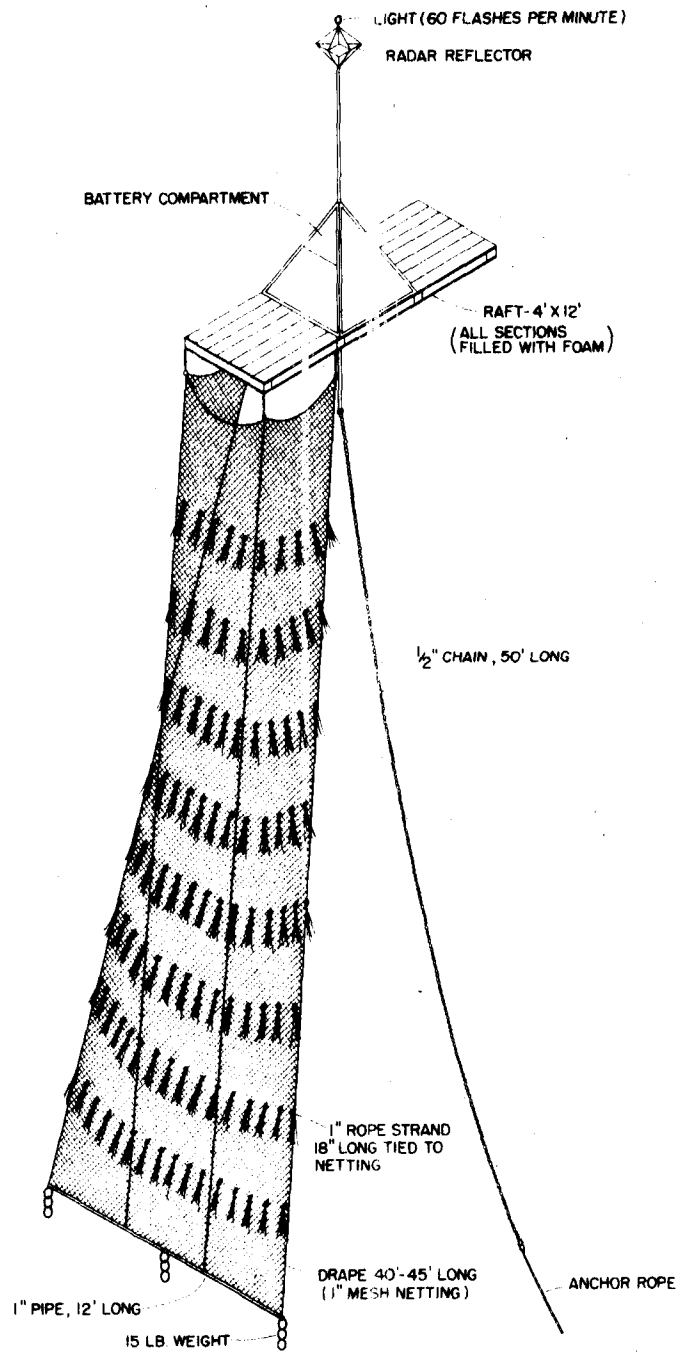

Figure 4.--Fish aggregating device, raft type.

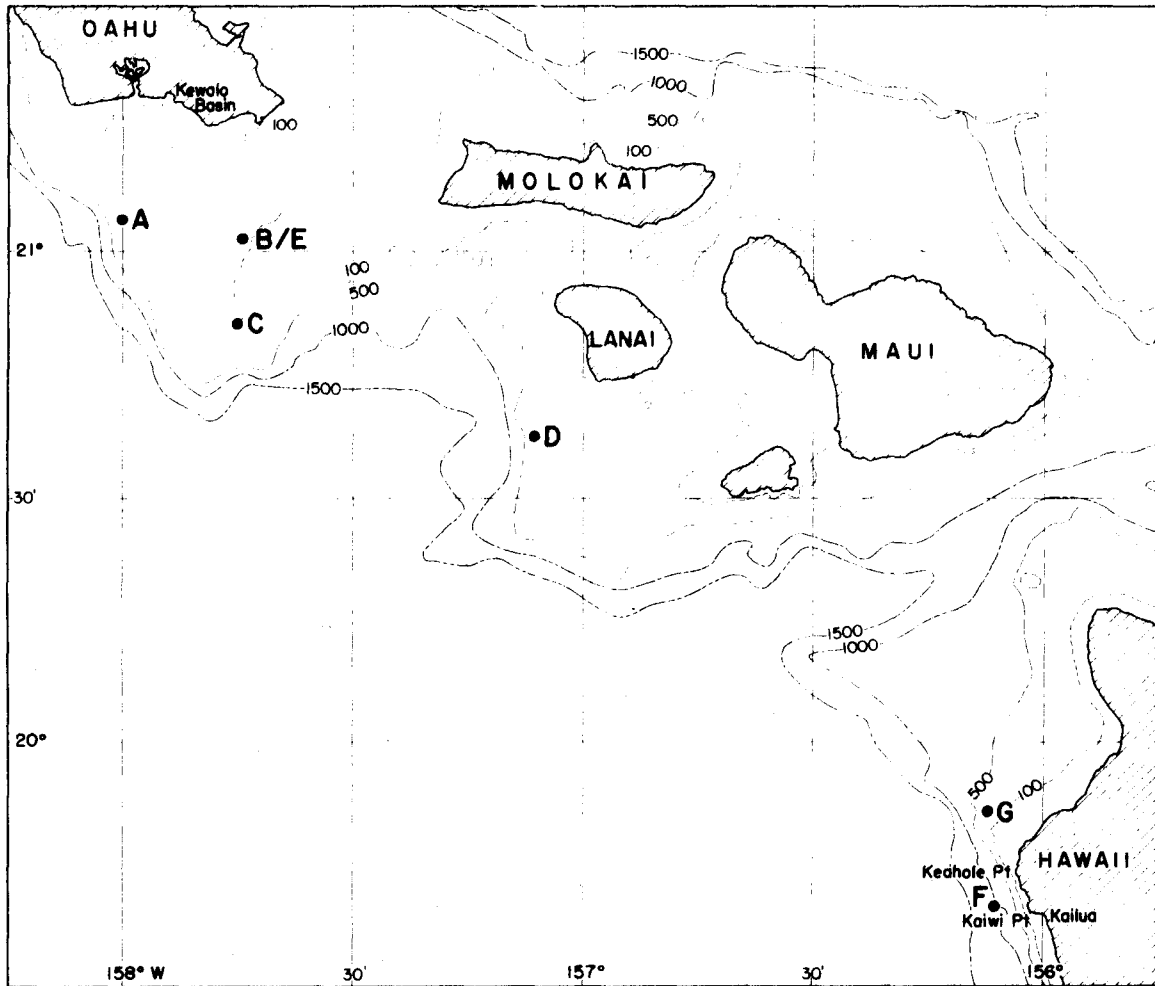

Figure 5.--Fish aggregating devices off Oahu, Lanai, and Hawaii.

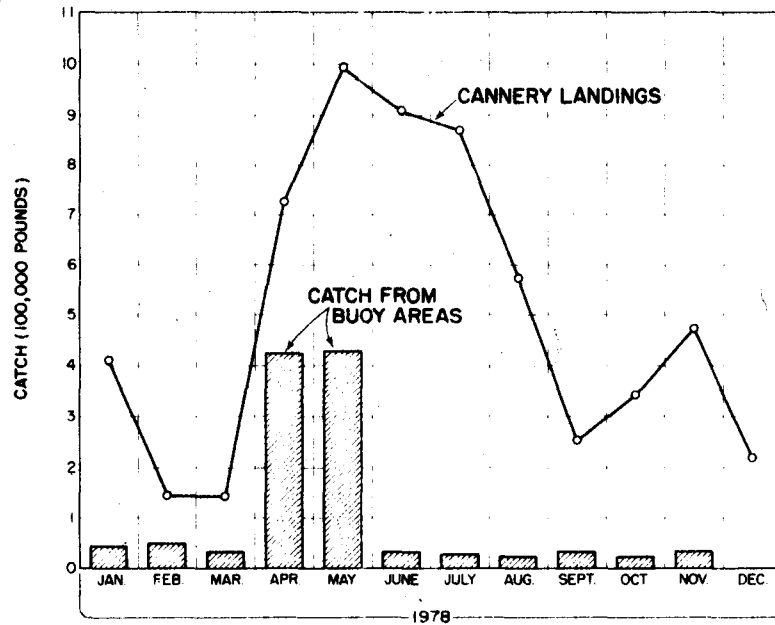

Figure 6.--Monthly catches of skipjack tuna around the buoys compared with monthly landings of skipjack tuna at Hawaiian Tuna Packers, December 1977-December 1978.

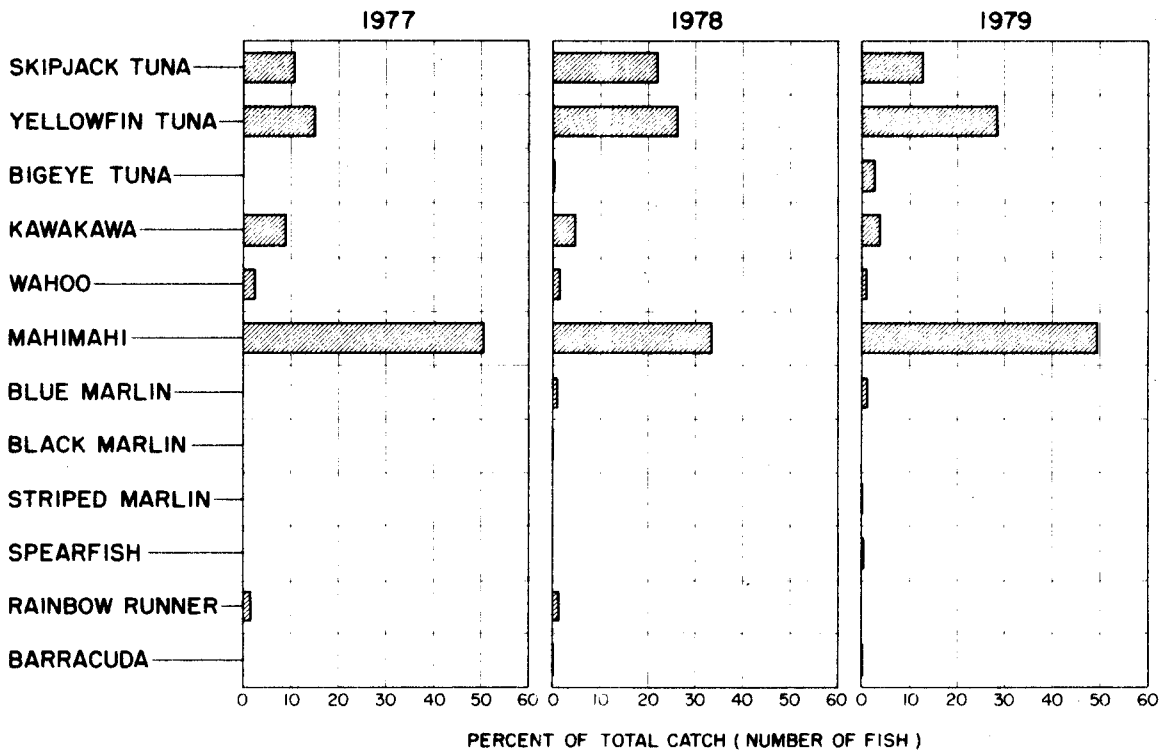

Figure 7.--Species of fish taken at buoys A, B/E, and C by trolling boats.