

CHAPTER 2

FISHING GEAR AND EQUIPMENT

- A. *The longline: basic gear configuration and storage*
- B. *Hydraulically powered machinery used with longline gear*
- C. *Mainline and branchline materials and connection points*
- D. *Branchline hardware*
- E. *Making up branchlines*
- F. *Floats, flagpoles and floatlines*
- G. *Radio buoys*
- H. *Vessel electronics*
- I. *Vessel hydraulics*

INTRODUCTION

This chapter describes the gear and equipment used for horizontal tuna longline fishing activities. It covers the basic gear configuration for both monofilament and rope gear, and the machinery, including hydraulics, used with both types of gear. The different gear components are described covering a selection of items that can be used based on a fisherman's preference, the gear type being used, and the habits of the species being targeted. Rigging the gear is covered to show different configurations that can be used. Vessel electronics are covered in detail as this equipment has become very important in locating good fishing areas and targeting the desired species to maximise catch.

A. THE LONGLINE: BASIC GEAR CONFIGURATION AND STORAGE

There are two basic types of longlines: traditional rope, also known as basket gear, and monofilament gear — with some combinations and variations. Basket gear evolved during the late nineteenth century and is still in use today, particularly in the Asian fleet. Monofilament gear evolved in the 1980s and revolutionised longline fishing by offering a less labour intensive and more efficient method of catching fish. Fundamentally, however, the two systems are similar.

A longline is made up of units or sections of line that are called baskets. A basket of longline gear is the amount of mainline and branchlines in between two floats. The term is used both for basket gear and for monofilament gear. A basket may contain from 4 to 40 branchlines. Typically, basket gear has small baskets of between 5 and 15 branchlines, while monofilament gear has baskets of between 15 and 40 branchlines. A branchline is a single line, sometimes made up of several materials joined together, with a snap at one end and a hook at the other.

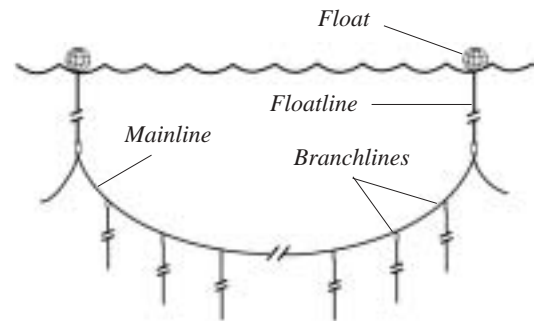

The entire longline might contain anywhere from 20 to 200 baskets, and consist of a mainline 5 to 100 nautical miles long. The mainline is suspended in the water by a series of floats, or buoys, that are attached to the mainline by floatlines. The line is set and hauled once a day from a moving vessel. It is allowed to drift or soak on its own for four to eight hours in between setting and hauling. A typical longline set from a medium-scale longliner would be about 30 to 60 nm long and have about 1200 to 2500 hooks. A typical longline trip on a medium-scale longliner would last about one to three weeks and the line would be set about 6 to 12 times — once each fishing day.

Basket gear

Basket gear is usually hauled with a line hauler, with the mainline either coiled into some type of basket or tub or tied up into a bundle, and then stowed in a cage or in bins. Branchlines are left connected to the mainline and either placed on top of each successive coil of mainline, or coiled and stored in a separate basket. The branchlines can also be detached and coiled individually, and placed in stacks or baskets for storage. Basket gear generally uses short floatlines and long branchlines to achieve a deep set.

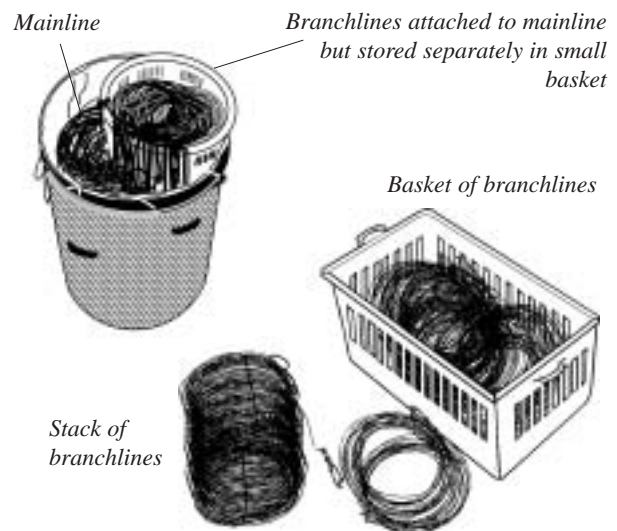

Monofilament longline

The components of a typical monofilament set are:

- radio buoy and float attached to bitter end of mainline;
- empty basket — 100 to 200 m of mainline with no branchlines;
- double float on 30 m floatline attached to mainline with snap;
- one full basket — 1050 m of mainline with 20 branchlines, each 12 m long, attached with snaps at 50 m intervals;
- single float on 30 m floatline;
- one full basket;
- double float on 30 m floatline;
- one full basket;
- single float on 30 m floatline;
- one full basket;
- double float with flag and strobe light on bamboo pole on 30 m floatline;
- one full basket ...



This pattern is repeated for 50 to 100 baskets. Another radio buoy is attached to the other end of the line following a last empty basket, and there may be two or three additional radio buoys spaced throughout the line. The empty baskets are placed on either end to avoid tangles. A shark or other large fish such as a marlin can swim the bitter end of the line for miles or, worse, tie it in knots. Also, an empty basket gives the crew a little bit of adjustment time when starting and finishing the haul.

Monofilament gear generally uses long floatlines and short branchlines to achieve the same depth of set as basket gear. This can be done because monofilament mainline is easier to haul from deep water as it gives less resistance in the water than tarred mainline. The result is that monofilament gear can get more hooks in the water over a given length of mainline. Another advantage that monofilament gear has over basket gear is that monofilament gear is less labour intensive. Monofilament gear is also easier for the crew to learn. The techniques can be mastered in a few trips, while basket gear may take several seasons to master. Lastly, monofilament gear is easier to maintain. Branchlines and mainline can be repaired easily during hauling operations.

Monofilament mainline is stored on the reel, while the branchlines are detached and stored separately in bins.

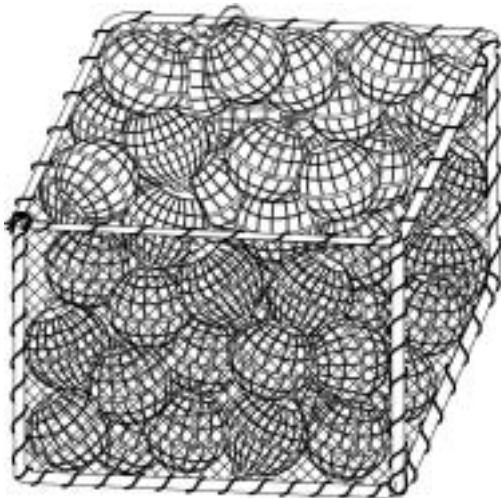

Floatlines are coiled and secured with the bitter end of the line in a quick release half hitch (also called a longline knot). The coiled floatlines are stored in a tub or bin.

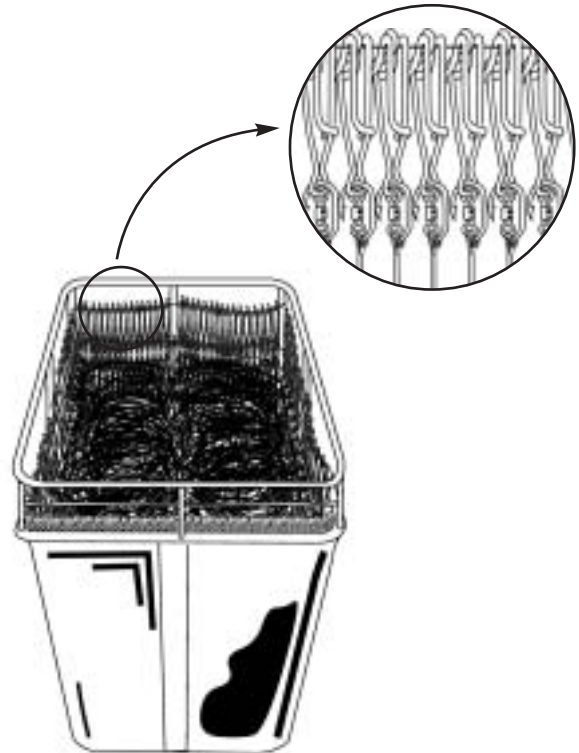

Floats

Floats for either style of longlining are generally stored in a cage or bin, and transported to the setting area when needed, or back to the cage when the gear is hauled.

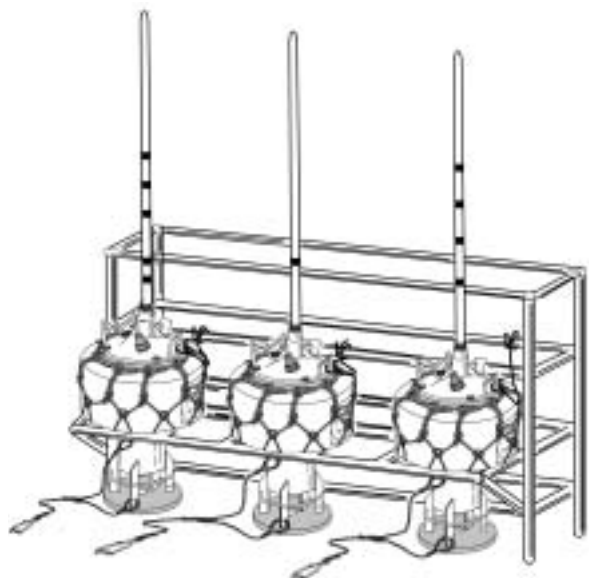

Radio buoys also need to be stowed carefully in an easily accessible area.

B. HYDRAULICALLY POWERED MACHINERY USED WITH LONGLINE GEAR

Several pieces of hydraulically powered machinery are used with rope gear. Monofilament gear also uses hydraulic machinery.

Line hauler for traditional rope gear

Traditional Japanese basket gear used no machinery. The line was set and hauled by hand. This changed in 1929, when the first Izui line hauler was developed. The mainline being hauled is fed around the main pulley wheel, with tension applied by a second rubber roller. As the gear is hauled aboard, each basket is coiled and detached from the rest of the line. The branchlines are either left attached to the mainline and guided through the hauler, or detached and stored separately.



Branchline coiler

If branchlines are detached from rope gear, they can be coiled either by hand, or on a coiling machine. The snap end is placed in the coiling machine, which winds or coils the branchline around it. The coiled branchline is then removed and ready for storage. The same machine can be used for coiling floatlines.

Automated rope system

The automated rope system uses a continuous mainline. The mainline is hauled using the line hauler, which coils the mainline onto a conveyor. The branchlines are removed and coiled using the branchline coiler. The mainline on the conveyor is transferred via a series of blocks and tubing to the line arranger, which coils the mainline into storage bins.

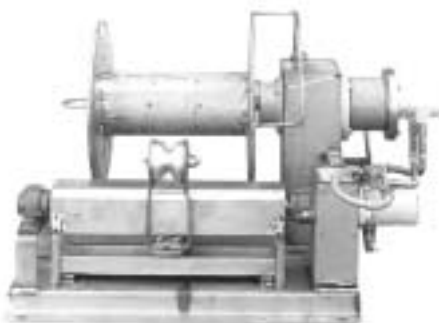
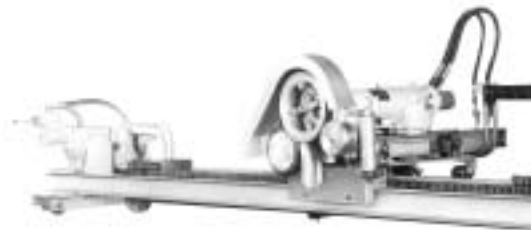

Japanese Magu reel system

A Japanese Magu reel system has the monofilament mainline hauled with a basket gear line hauler. The branchlines are removed and either coiled by hand or coiled with a branchline coiler. A separate line winding machine winds the mainline onto small removable spools. When each spool is full, it is removed from the winder and stowed, and an empty spool placed on the winder.

Monofilament reel system

A monofilament reel system uses a hydraulic reel to haul and store the mainline. Blocks are used to guide the line to the reel. The reels come in sizes to suit different size boats. Small reels hold 5 to 10 nm of mainline, large single reels can hold up to 60 nm of mainline, while double reels can hold over 100 nm. Reel capacity is also governed by the diameter (3.0 to 4.5 mm) of the monofilament mainline.



Small single reel system

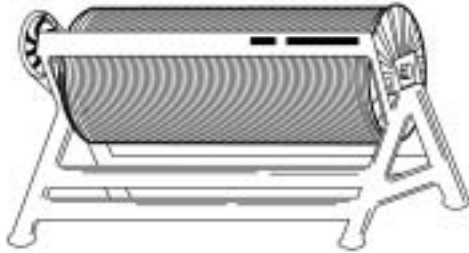

Large single reel system

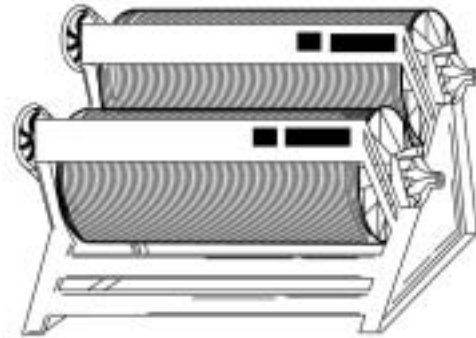

Double reel system

Line setters

Line setters, or shooters, can be used for setting continuous rope or monofilament lines. The line setter deploys the mainline at a predetermined speed, which is faster than the vessel is travelling. This gives the fish master control over depth of the mainline. The branchlines, floats and floatlines are snapped onto the mainline at regular intervals. Line setters are slightly different for rope and monofilament gear, because of the type and size of the mainline.

Line setter for monofilament gear



Line setter for rope gear



A line setter cannot be used on rope gear where the branchlines are left attached to the mainline, or where the mainline is stored in disconnected section. In these cases, coils of mainline are thrown by hand in such a way that the line is going out at a rate faster than the boat is travelling.

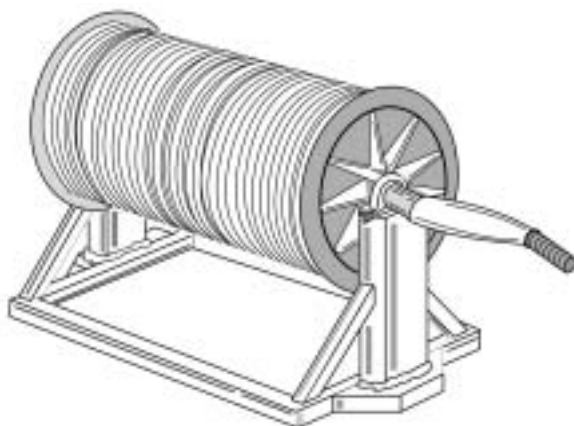

Manually operated reel

A hand-crank reel can also be used for storing the monofilament mainline. This is sometimes used on small-scale vessels where a short, 5 nm mainline is used. The reel is operated manually by one or two crew for both setting and hauling.

C. MAINLINE AND BRANCHLINE MATERIALS AND CONNECTION POINTS

Two materials can be used as the mainline for horizontal longlines — tarred rope and monofilament.

Tarred rope

Basket gear is made from tarred rope. The mainline for basket gear can range from 4 to 8 mm in diameter, but 6.4 mm is the most common. Each basket of gear has the mainline connected to the previous basket using a sheet bend.

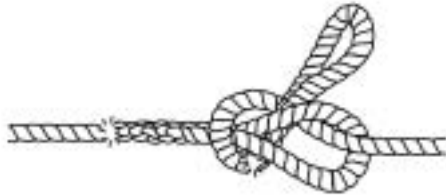

Branchlines are usually spaced about 50 m apart on the mainline, and are attached to specific joints made with two eye splices, using a sheet bend. Floatlines with floats are attached between the baskets, also on joints.



Automated continuous rope gear does not have connection points for the branchlines or floatlines. They are snapped straight onto the mainline at the appropriate intervals.



Branchline materials

A range of materials can be used for making up branchlines, either on their own or combined through joining the materials together.

Monofilament

Monofilament mainline ranges from 3.0 to 4.5 mm in diameter. The hydraulically powered reel system is the most common method used with monofilament. The mainline is continuous and the only knots in the line are where the line has been joined after breaking or being cut to remove tangles. Branchlines and floatlines are connected to the mainline with snaps. This allows greater versatility with the gear, as the spacing between branchlines and floatlines can be easily changed.

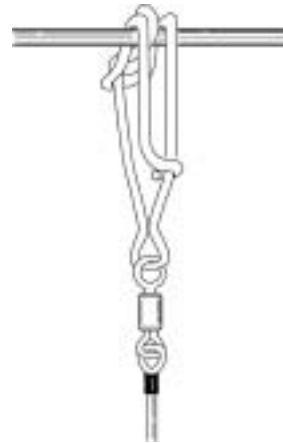

A few fishermen sometimes use two sleeves crimped onto the mainline or a knot to mark off the spot where branchlines and floatlines are to be snapped on a mainline, and to keep the snaps from sliding. Most longline fishermen, however, do not do this, as it is impractical and can be dangerous. Also it is much slower to haul mainline that has sleeves marking the attachment points as the reel has to be stopped for every snap. It is much faster and safer to have the monofilament mainline clear, with no sleeves and few knots, so the branchline and floatline snaps can slide while they are being unsnapped.

Some Asian vessels continue to use a basket-type arrangement, with the branchlines left attached to the monofilament mainline at connection points similar to those used as for rope basket gear. A snap is usually used to connect each basket of monofilament mainline to the next.



Tarred line

For basket gear, the same tarred line as used for the mainline, usually 6.4 mm diameter, is often used as the top part of a branchline. Connections are usually made with a splice or with a sheet bend. The tarred rope usually comes in standard coils.



Monofilament line

Clear or coloured monofilament of 1.8 to 2.1 mm is a common material used for branchlines. Per metre, monofilament is the cheapest material to use and is easy to work with. Its elasticity assists in the playing of fish to the boat, although the line is slippery to handle. The monofilament can form part or all of the branchline. Connections are usually made with crimps, although knots can be used. The line comes in loose hanks or skeins or on wooden spools, depending on the quantity being purchased.

Tarred red polyester line

Tarred red polyester, 3.0 to 3.5 mm in diameter, is popular in some places as a branchline material. Slip knots, splices or crimps can be used for making connections. Tarred red polyester has some advantages over monofilament for branchlines. It is easier to handle because the line does not retain kinks like monofilament does, it sets easier, and it is easier to coil the lines back into the branchline bins. Also, if there is a large fish on the line the fisherman can grip the line better to pull the fish in. Tarred red polyester branchlines do not tangle with the monofilament mainline as much as monofilament branchlines. Tarred red polyester line comes in standard coils.

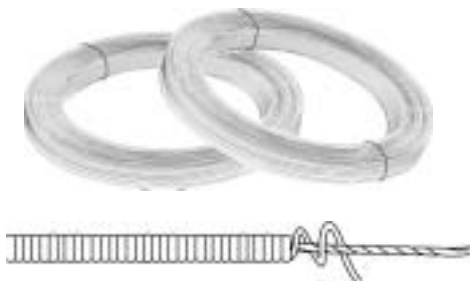

Sekiyama wire

Sekiyama wire, often called middle wire, is sometimes used as the middle material on branchlines for basket gear. The added weight of this material assists in the sinking of the line, and retaining a deeper set. The centre wire is bound with cotton or synthetic fibre and usually tarred. Connections are made using eye to eye joints, with the eyes usually secured by crimps. Sekiyama wire comes in coils.

Turimoto galvanised longline wire

Turimoto (No. 27, 3 x 3 strand) galvanised wire is sometimes used for the trace or leader, which connects the hook to the rest of the branchline. It is used as protection from fish with sharp teeth, such as sharks. Connections are made using crimps and the wire comes in coils



Stainless steel wire

Stainless steel (1.6 mm, 7 x 7 strand) wire is also used as trace or leader material, connecting the hook to the rest of the branchline. This is mainly used with stainless steel hooks to reduce electrolytic reaction. Connections are made with crimps and the wire comes on a spool.

D. BRANCHLINE HARDWARE

There are several pieces of hardware used in the construction of branchlines, including snaps, swivels, hooks and sleeves.

Snaps



The swivel snap — often called a clip — is a very important component of a branchline. There are different snaps for rope and monofilament gear, and they should not be interchanged, as they will not work properly. Snaps made for rope gear have a jaw that is too big to grip monofilament mainline. The branchlines will slide freely and cause tangles. Conversely, the jaw of a snap for monofilament gear is too small to work properly on the larger diameter rope gear.

The snaps used on rope gear — often called tuna snaps or shark clips — have a jaw size to grip the 6.4 mm tarred rope. These snaps are also used on the floats, to attach them to the floatline. The most common size is the 3.5 mm (size of wire used) x 125 or 150 mm (length) snap for rope, which can come with or without a No. 2 BL swivel.

A suitable monofilament snap has a tight jaw that grips the monofilament mainline. Monofilament snaps are often called American snaps. The best snaps for 3.0 to 3.5 mm monofilament mainline are the 0.135 x 1/8 inch snaps with 8/0 crane swivel (0.135 is the wire size and 3.0 mm the jaw opening). The jaw opening is the correct size for gripping 3.0 to 3.5 mm monofilament mainline, and the 8/0 swivel is the correct size for 1.8 to 2.1 mm monofilament. Suitable snaps for 3.5 to 4.5 mm mainline are 0.148 x 3/16 inch with an 8/0 crane swivel (0.148 wire size and 4.50 mm jaw opening). The wire is stiffer and the jaw is bigger to accommodate the larger mainline, but the swivel is the same.

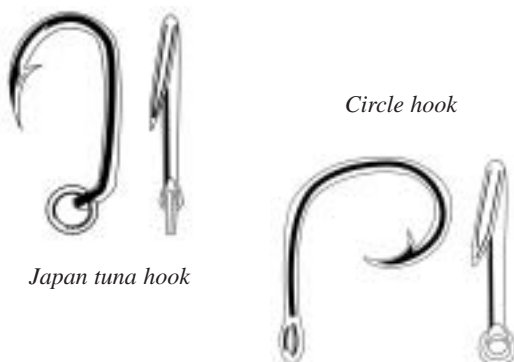
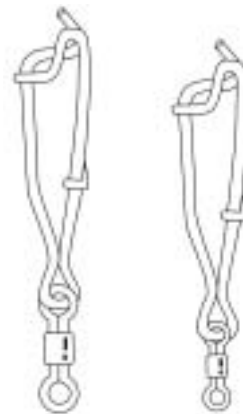

Japan tuna hook

Circle hook

Hooks

Branchlines can be made with three different types of hook: Japan tuna hook with ring, tuna circle hook, or big-game hook. Japan tuna hooks come in sizes ranging from 3.4 to 4.0 *sun* but 3.6 is the most popular (the number is a Japanese measurement). Tuna circle hooks come in a range of sizes, with the sizes 14/0 to 16/0 the most popular for pelagic longlining.

Big-game hooks (also called ‘J’ hooks), are the most popular hooks when fishing for swordfish. Sizes are usually 8/0 or 9/0. Japan tuna hooks and tuna circle hooks do not work as well with swordfish. The mouth of the swordfish, particularly the bottom jaw, is soft compared to other fish, so a larger hook is required.



Game hook

All of these hook types are available in either galvanised steel or stainless steel. Stainless steel hooks last longer than galvanised hooks but are more expensive. Since they last longer, however, they may be less expensive in the long run. One of the problems with galvanised hooks is that when they are hanging in the branchline bin they are in contact with a stainless steel snap. The presence of a dissimilar metal promotes electrolysis and, thus, the hooks rust rapidly. Electrolysis can also occur with hooks where the hook and ring are made of different metals.

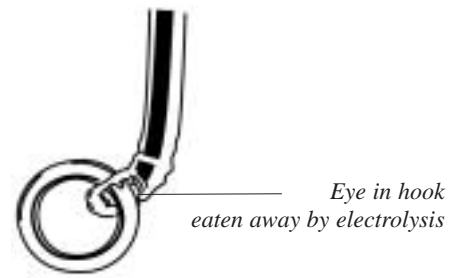

Swivels

The most common swivels used in branchline construction are the leaded types, which come in 38, 45, 60 and 75 g sizes. The leaded swivels are used to increase the sinking rate of the gear and baited hook, to add weight to keep the branchline deeper in the water, especially in rough weather, or to provide a connection point in the branchline between the main part and the leader. Leaded swivels can be very dangerous, particularly when a large fish or shark stretches the branchline and then throws the hook. The swivel can fly back towards the boat at terrific speed. Fishermen should never stand in direct line with a stretched branchline.



Other swivels can be used in the construction of branchlines, although they do not have the weight of the leaded swivel. Box and BL swivels can be used on rope gear, both in the mainline and in the construction of branchlines. For monofilament branchlines, crane or torpedo swivels can be used.

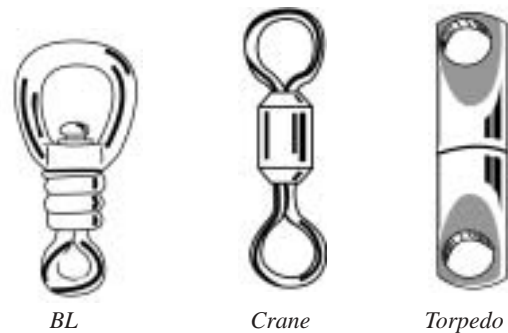

BL

Crane

Torpedo

Lightsticks

Lightsticks are used in the swordfish fishery to attract the fish to the baited hook. Disposable lightsticks rely on a chemical reaction that emits light for 8 to 12 hours. An alternative to the chemical lightstick is a battery operated pressure light that can be used for many days before changing the batteries. Both devices are effective with swordfish and bigeye and come in a range of colours. Disposable lightsticks should not be discarded at sea.

Glow beads

Glow beads are luminescent beads, which are sometimes used on branchlines just above the hook. The theory is that the beads, being luminescent, will help to attract fish to the baited hook, much the same as a lightstick does. Some fishermen claim that glow beads attract some bycatch species, such as snake mackerel. In any event, they are not widely used.

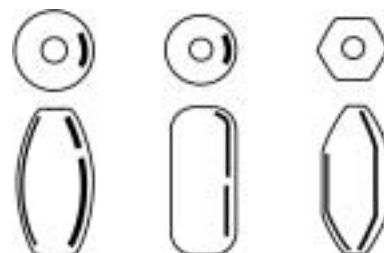

E. MAKING UP BRANCLINES

Making up branchlines is easy if you have the correct components, materials and equipment. Branchlines can be simple in their construction, with just a length of monofilament joining the hook to the swivel snap, or more complicated with up to three materials used between the hook and swivel snap. The branchlines described below are a selection of only the most common designs, as there are many configurations that can be used.

It should be noted that most crimped connections made in the construction of branchlines have loop protectors (Chapter 1 H) over the end of the line.

Simple monofilament branchline

The simplest branchline has a swivel snap of the appropriate size connected to 10 to 15 m of 1.8 to 2.1 mm monofilament, with a hook crimped to the other end (a).

Monofilament branchline with leaded swivel

A leaded swivel can be added to the simple monofilament branchline, by crimping it into the line, 0.5 to 2 m above the hook (b).

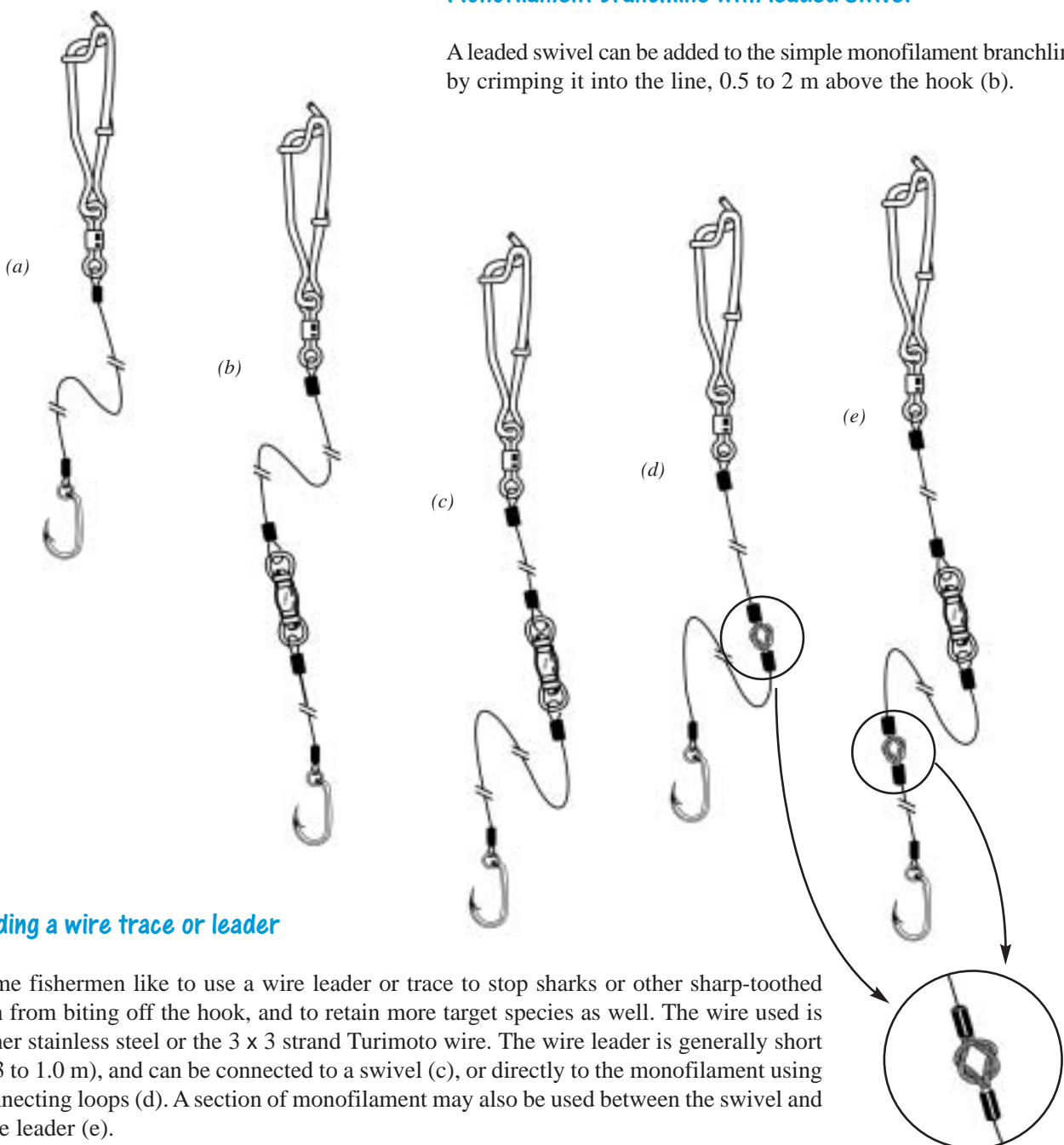

Adding a wire trace or leader

Some fishermen like to use a wire leader or trace to stop sharks or other sharp-toothed fish from biting off the hook, and to retain more target species as well. The wire used is either stainless steel or the 3 x 3 strand Turimoto wire. The wire leader is generally short (0.3 to 1.0 m), and can be connected to a swivel (c), or directly to the monofilament using connecting loops (d). A section of monofilament may also be used between the swivel and wire leader (e).

Red polyester branchline

Red polyester line can be used instead of monofilament (10 to 15 m in length), although this material is not connected directly to the hook as it chafes easily. Therefore, a swivel is generally used from 0.5 to 2.0 m above the hook. There may be a wire leader, monofilament or a combination of the two between the hook and swivel. A slip knot, crimp or splice is used to connect the red line to the swivel snap and swivel.

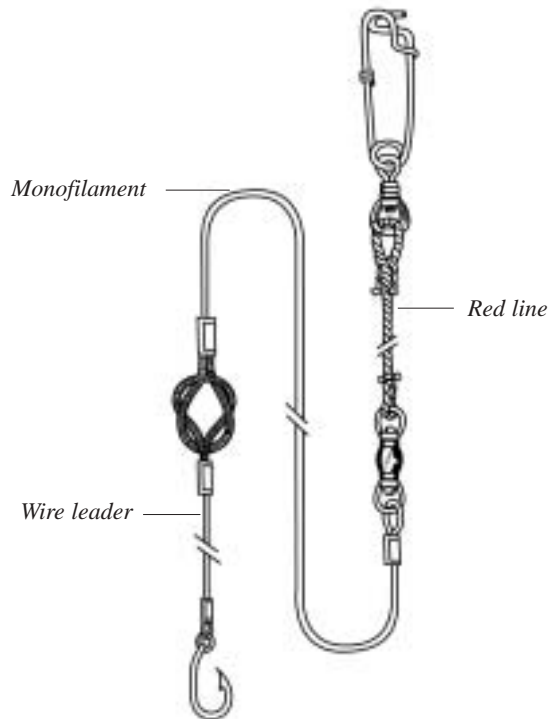

Tarred rope combination branchline

Tarred rope combination branchlines are mainly used with basket or tarred rope gear, and consist of three or four materials joined together. The branchlines are longer, from 20 to 35 m in length overall. The snap is spliced onto one end of the tarred line (10 to 20 m long), with a leaded, box or BL-type swivel spliced onto the other end. A short piece of tarred line (0.5 m) is spliced to the other side of the swivel, with this line ending in a back splice.

The second section (10 to 20 m long) can either be red polyester line, Sekiyama middle wire or monofilament. The second section has a loop with loop protector on each end, with the loops usually secured by crimps. This section is then connected to the loose end by passing one loop through the other and passing the line through the loop, or through using a sheet bend. The idea of the connections is to allow the branchline to be disconnected easily when the gear is tangled or damaged.

The third section can be a wire leader or monofilament, with a loop and loop protector on one end and the other crimped to the hook. If a fourth section is used, this is usually a wire leader, which would be connected to the monofilament by loops, and the hook secured by a crimp.

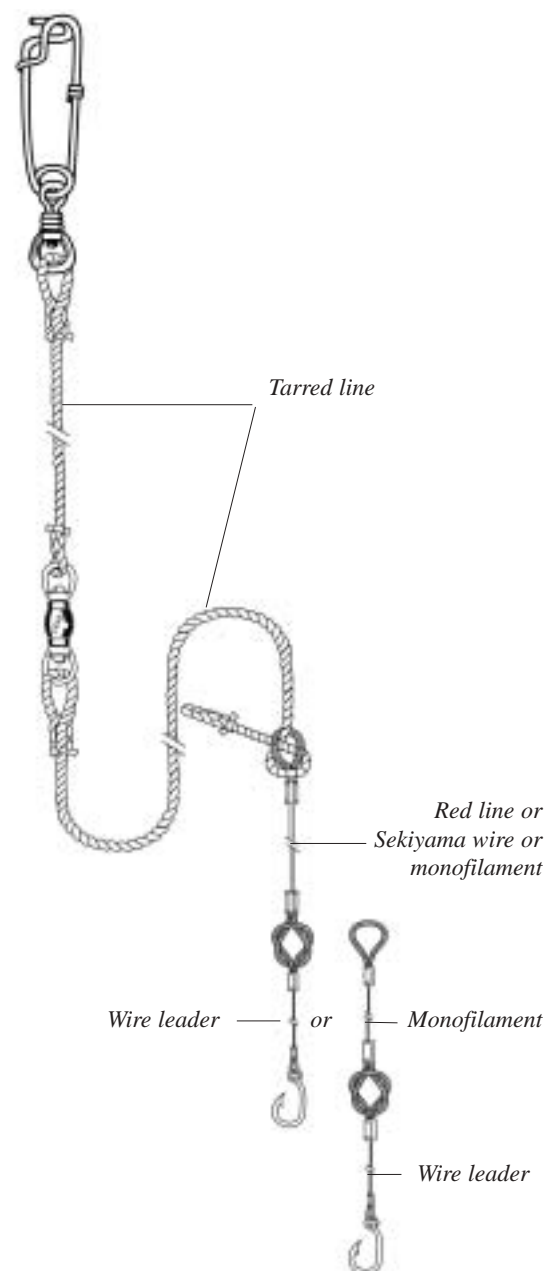

F. FLOATS, FLAGPOLES AND FLOATLINES

There are several different types of floats used in longline fishing including glass floats, hard plastic floats, inflatable buoys, bullet buoys, and solid foam floats. The most popular floats for monofilament longline fishing are hard plastic floats that range from 165 to 360 mm in diameter. These floats usually have one or two ears — eyes for attaching line — and are ribbed on the outside so they pull through the water easily. Glass floats were popular years ago with Japanese basket gear. Glass floats need to have a net made from tarred rope, as they do not have attachment ears and they are easily broken. Hard plastic floats often have tarred rope netting around them as well. Inflatable floats and foam floats are not very good for tuna longlines as they are compressible and could collapse if a fish drags them down deep. Foam floats and bullet buoys are often used on swordfish longlines, however. Plastic floats for tuna longlines should be pressure rated down to 200 to 300 m.

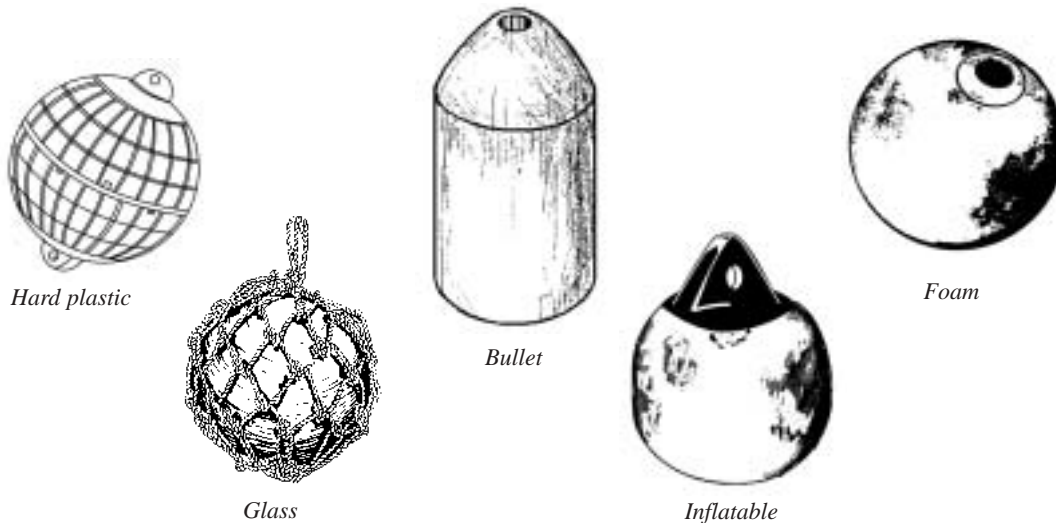

Floats are usually attached to the floatline with a swivel snap that is spliced onto a short length of 6.4 mm tarred line, 1 m long. The swivel snap is attached with a tight eye splice that goes through the eye of the swivel. The other end of the line has an eye splice 15 cm long. When the splices are done the line should be about 75 cm long.

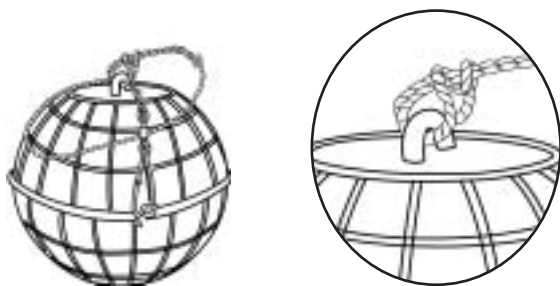
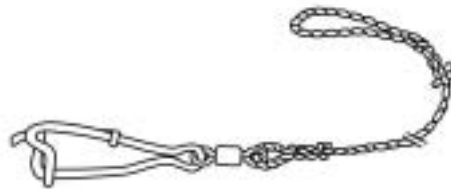

A good way to attach the short line to the float is to run the eye splice through the ear, double the eye over, then run the end with the snap through the double loop. The result is a knot that will tighten up on the standing part of the rope and will not move on the ear of the float. This knot will not chaff through.

If the eye splice is put through the ear and just looped back over the standing part of the line, the connection will be loose and eventually the line will wear through.

Reflective tape should be stuck onto all plastic floats so they can be seen at night. Metal reflective plates or tubes or lights can also be attached to floats. One type of float comes with a threaded hole in the top, where a strobe light can be screwed in.

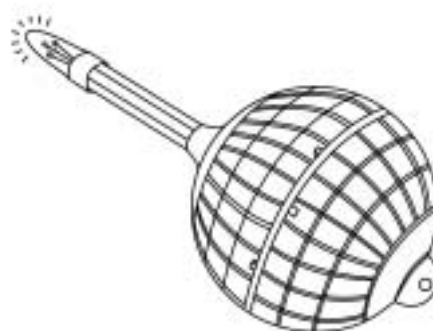

Flagpoles

Flagpoles are used to add height to a flag or radar reflector to make it easier to locate. Some floats come with a hole through the centre, so a pole (bamboo, fibreglass or aluminium) can be passed through and secured, with a weight on the bottom and the flag (a), light and/or radar reflector mounted on top or lashed to the upper part of the pole.

When using a standard longline float, there are two common ways to secure the pole. First, the pole is lashed to the float with around one-third of the pole below and two-thirds above the float. A weight or steel rebar is lashed to the bottom part of the pole (b), with a flag and/or reflector on the top, and possibly a strobe light for night use.

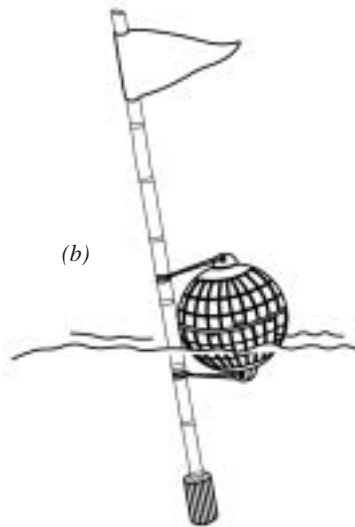
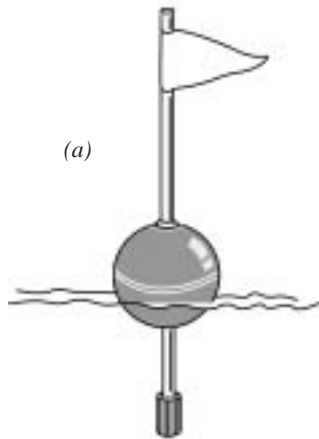

The second method is to have the flagpole separate from the float, just attached to it. In this case, the pole is weighted on the bottom and a flag placed on the top. A short piece of tarred line is attached to the pole so that it can be attached to the float either by a snap or a sheet bend. The pole sits beside the float in the water with the weight keeping the pole upright (c). This allows the flagpoles to be stored separately, plus it allows the floats to be used for other purposes as well.

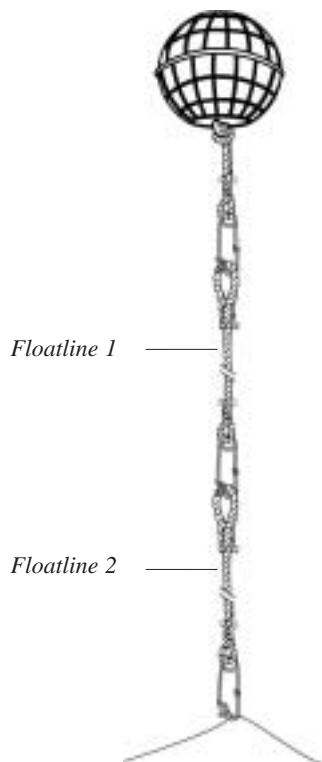
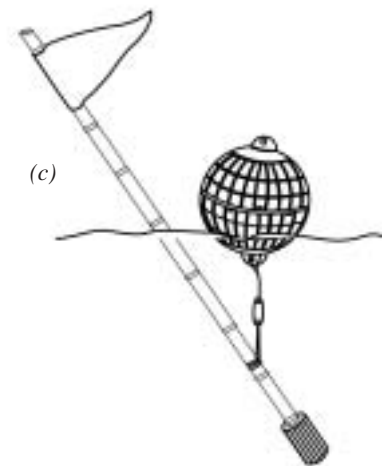

Floatlines

Floatlines are usually made from black or red vinyl tarred line. The average diameter of floatlines is 6.4 mm but rope slightly smaller or larger will do. Polypropylene rope, or rope made from other floating material, is not a good choice as it will tend to float the entire mainline to the surface, away from the target fish, which are down deep. Floatlines can range from 10 to 40 m or more in length, depending on target species. For tuna, average floatlines would be about 30 m long, while for broadbill swordfish, floatlines may range from 10 to 20 m. The floatline has an eye splice in one end for attaching to the float, and a swivel snap on the other for attaching to the mainline. It is made exactly like the short line on the float except that the line is much longer. Floatlines can also be snapped together to make longer floatlines.

As an alternative, floatlines can be made from monofilament mainline using crimps to form the eyes and to attach the snaps. Some longline boats use small hand operated drums, called leadercarts, to haul and store monofilament floatlines.

G. RADIO BUOYS

Radio buoys and radio direction finders (RDF) allow longline fishermen to have a more relaxed break while the line is soaking. Radio buoys give out signals that are picked up by the RDF on the fishing boat from as far away as 35 nm, so the fishermen can sleep while the line is soaking, knowing that they will be able to find the line later.

Radio buoys require special rigging and special maintenance. Radio buoys usually come with a flotation collar made of canvas covered foam. The collar is usually attached to the body of the buoy with a shoelace-like cord, which is not very durable. If the collar is lost the buoy will sink and likely implode under pressure and be destroyed. A simple way to prevent the collar from coming off is to tie a net around it similar to the tarred rope net tied around glass floats. Also, the flotation of the collar is sufficient only for floating the radio buoy so another float must be attached to the line close to the radio buoy.

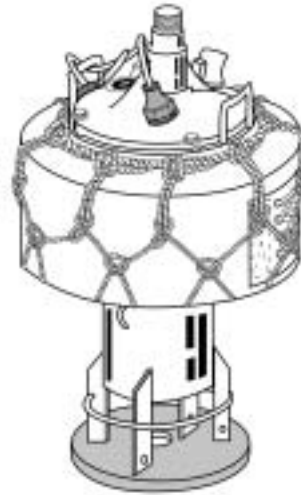

Radio buoy with netting

Another component that is necessary on a radio buoy is a strong bridle. The bridle can be made of heavier rope than the floatlines, such as 12 mm three-strand polypropylene, but 6.4 mm tarred rope will do. The bridle should be attached to two different places on the radio buoy. There are padeyes or rings on the buoy for attaching the bridle. Short pieces of plastic hose should be slipped over the rope before the eye splices are made. This prevents chaffing. A heavy-duty longline snap should be attached to the end of the bridle for attachment to the floatline.

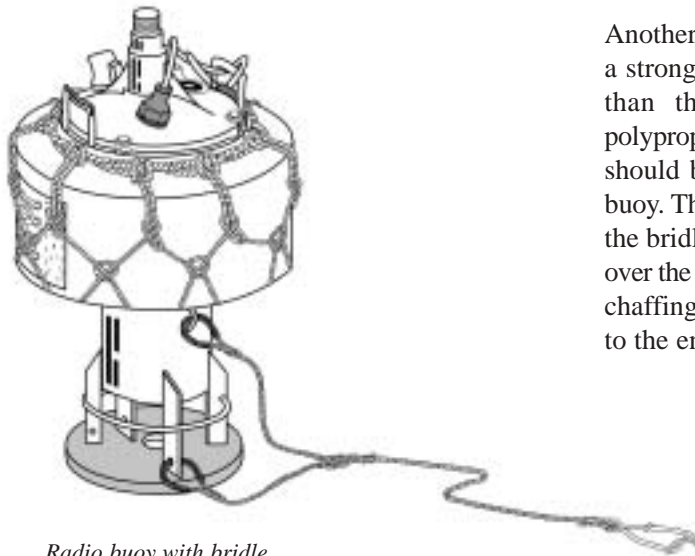

Radio buoy with bridle

Finally, two small tie-downs made from tarred rope should be attached to the handles of the radio buoy. On board, the radio buoy should always be secured to the rail or some other spot on the deck so that it cannot tip over. As soon as the radio buoy is recovered from the sea, it should be turned off. The switch should never be turned to the on or test position unless the antenna and antenna wire are connected to the transmitter.

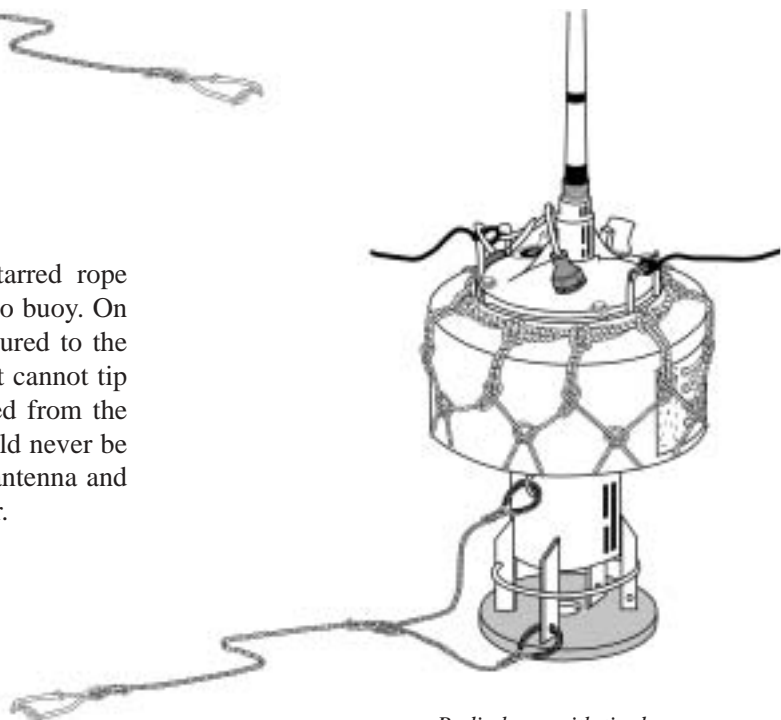

Radio buoy with tie-downs

Radio buoys are powered by batteries that come as a canister or as a battery pack with up to 36 D-cell torch batteries. The D-cell packs are probably the best for the Pacific Islands as D-cells are readily available almost anywhere, and they are less expensive than the imported canister packs. When the signal from the radio buoy weakens it is time to change the batteries. Whenever this is done, the radio buoy should also be checked out. Any moisture inside the cylinder holding the battery pack and transmitter should be removed.

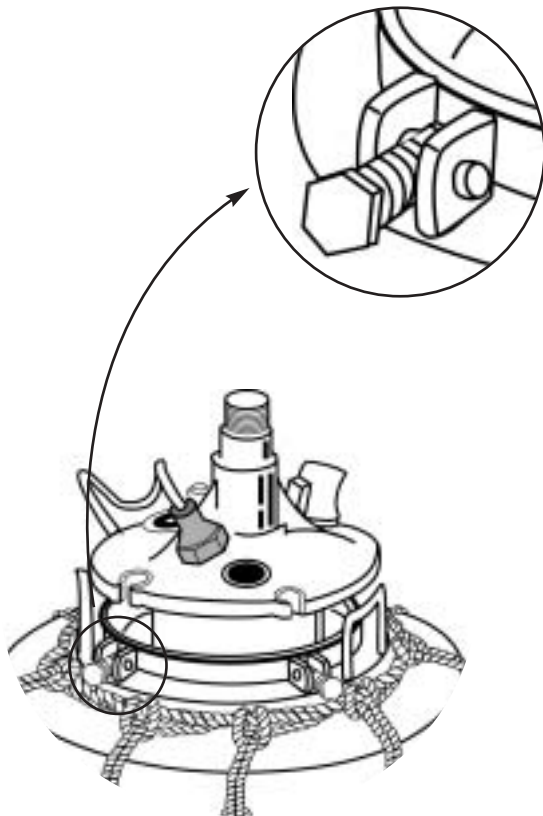

Special select call radio buoys (Sel-Call) are available that give out a signal only when they are called. When these buoys are used, other boats cannot eavesdrop on the signal and figure out where the boat is fishing. They are more expensive than regular radio buoys and another piece of equipment is needed, the radio that calls the buoy. There are also RDF and radio buoy systems that provide GPS positions and sea surface temperature.



The inside of the cylinder, the battery pack, all terminals, and the transmitter should be sprayed with a light coating of silicone spray. The O-ring seal on the lid of the cylinder should be sprayed with silicone or, better yet, coated with silicone grease. The dogging bolts that seal the cover of the transmitter should also be sprayed with silicone spray. All joints on the antenna should be sprayed with silicone and tightened. They should also be wrapped in plastic electrician's tape so they cannot work loose. If a flag is attached to the antenna, care must be taken not to cover the antenna tip. This is where the signal is transmitted from. If it is covered or damaged the radio buoy may not work.

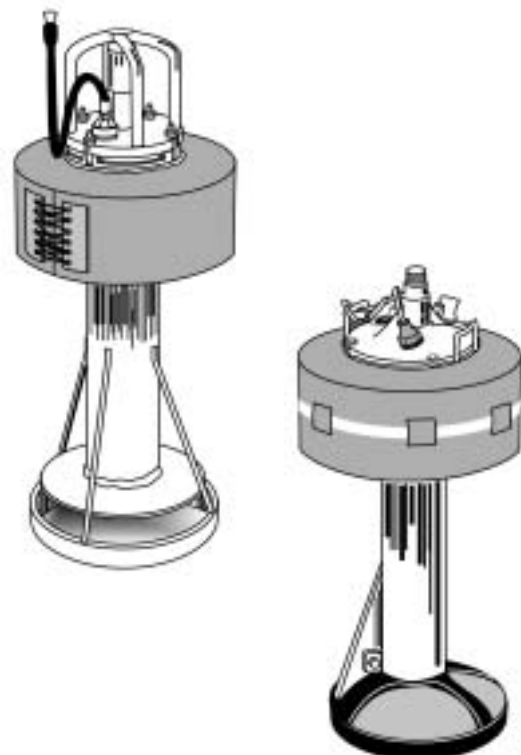

H. VESSEL ELECTRONICS

The following electronic appliances are essential to safe navigation and successful longline fishing, highly recommended, or optional. A prudent mariner, however, will not depend solely on electronic aids for safe navigation. He will always verify position, course, and speed with a magnetic compass, paper charts, and local knowledge; and will always maintain a proper lookout in the wheelhouse.

Essential electronic equipment

GPS — Global Positioning System receiver: gives vessel position in latitude and longitude at intervals of every second, accurate to within about 30 m. A GPS navigator is essential for both longline fishing and general navigation.



Radar: is essential for safe navigation, especially in areas where there are abundant reefs or where there may be other vessels. If fishing is done within radar range of shore, radar can be used to plot positions of a longline set. A radar unit with a 24 nm range should be sufficient for a small-scale longline vessel, while 36 nm range should be sufficient for a medium-scale longline vessel.

SSB — single sideband, or HF — high frequency radio: is essential for communication both for general navigation (ship-to-ship and ship-to-shore) and for fishing. Longline vessels can share catch and fish location information with each other, and can relay catch data and ETA (estimated time of arrival) to their agent or manager on shore. With an export fishery that depends on air links to Japan and other international markets, good communications are critical. Digital SSB radios with LCD readout are best. The SSB should be capable of operating in all ITU modes and on all ITU frequencies.



VHF — very high frequency radio: provides short range radio communications, essential for communicating with harbour authorities, with agents, and with other vessels in crossing situations to avoid collisions.

SST — sea surface temperature monitor: SST data are important for longline fishing, as both tunas and broadbill swordfish are often associated with temperature fronts (Chapter 3 C). The best SST monitors have shear alarms that give off an audible signal when the temperature rises or falls significantly.



Highly recommended electronic equipment

Autopilot: is helpful for setting the gear as it relieves one man from steering the vessel. Often this man is needed on deck to help with the set. An autopilot also gives a much straighter set than hand steering would. Some autopilots can also be used during hauling. The best autopilots for longline fishing have dial control knobs for course changes, rather than touch pads, and remote controls with dial control knobs.



Colour echo sounder: is important for navigation, especially in strange waters when entering harbours or going through passes in outer reefs. Another function of a sounder is its ability to 'find' fish. In fact, sounders are often called 'fish finders'. This is not important so much for locating schools of tuna as for locating bait that tuna or swordfish may be feeding on. Some sounders have the capability of reading the depth of the thermocline (Chapter 3 E). Some are equipped with sea surface temperature sensors and are able to display this information graphically on a time line. The most suitable sounder for a longline vessel would be a 1.0 kW model with a 50 kHz transducer (depth rating to at least 1000 m) and graphic SST function.



Colour plotter: can be separate from the GPS or can have a built in GPS receiver. A plotter is used for general navigation, but can be very useful for longline fishing as it gives more detailed information about the longline set. The plotter draws a picture or plot of how the line was set and how it was hauled. A comparison of the set and haul plots gives the skipper important information about set and drift — current direction and speed — and the presence of eddies or convergences (Chapter 3 C). Events such as fish catches can be entered on the plotter easily by pushing the 'event' or marker button. Geographical features such as reefs can also be entered onto the plotter. Many modern plotters include chart cards with global coverage. Some chart cards show bathymetry, reefs, and navigational aids as well as geographical features.



RDF — radio direction finder and radio buoys (Chapter 2 G): are not essential items as longliners operated throughout the world for years using only lights and coloured flags on bamboo poles to locate their lines. Besides finding radio buoys, RDFs can also be useful as navigation aids. Most RDFs are capable of giving a bearing to land based airport beacons and to AM radio stations. More sophisticated RDFs can be used to eavesdrop on other longliners to gain fishing information.

Weather facsimile receiver, or weather fax: receives weather information that is faxed worldwide on a number of frequencies. The information comes as synoptic weather maps (Chapter 1 L), which are much more detailed than reports given on HF radio or on Inmarsat-C systems. Remote sensing data, such as SST data, can also be received on a weather fax. A weather fax is a valuable item on any longliner operating in the cyclone belt.



Optional electronic equipment

BTG — Bathythermograph: is an instrument that measures temperature against depth. It is useful for finding the depth of the thermocline and for graphing temperature profiles (Chapter 3 E). There are reusable bathythermographs as well as portable disposable bathythermographs, which are called expendable bathythermographs or XBT.

Doppler current meters — also called acoustic doppler current profilers, or ADCPs: are capable of showing currents not only at the surface but also at a variety of depths. Up to three layers of water can be monitored even while the vessel is underway. This information could be important in deciding what depth and direction to set the longline.

Inmarsat systems: allow ship-to-ship and ship-to-shore satellite communication. Inmarsat-C does this in a fax or email mode. Inmarsat-A has voice communication capabilities as well, but is too expensive for most longline operations. No one can eavesdrop on a fax transmission, so two boats can share confidential fishing information with each other. Weather and distress messages are also transmitted on Inmarsat-C.



PC — personal computer: is becoming more and more of a necessity on fishing boats. A PC is necessary for two-way communications on Inmarsat-C using software such as Galaxy; and software is available with charts for course plotting, for monitoring weather, for getting real-time satellite oceanographic data such as sea surface temperatures and weather, and for managing the business of a fishing boat.

TDR — temperature-depth recorders: are very small reusable BTGs that can be attached to branchlines to monitor depth and temperature at set intervals along the longline set. They can also be called temperature profiling probes, or data loggers, or micro-bathythermographs. TDRs record temperature, depth, and time digitally and this data can be downloaded to a PC. They can also double as hook timers as the depth/time function usually shows changes that indicate when a fish was hooked: the depth decreases or increases showing a spike in the graph.

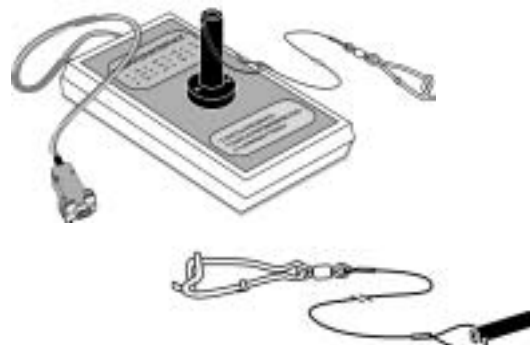

VMS — vessel monitoring systems: make use of an on-board transceiver called an automatic location communicator, or ALC. The ALC sends and receives messages via Inmarsat-C to a land base via a land earth station, or LES. The land base can track the position of a fishing boat in real time and can also ascertain if the boat is fishing or not by the signature of the tracks. The shore base can also request a position from a vessel through a polling mechanism at any time, and it is automatically relayed. Governments in the region are implementing VMS regulations, and eventually VMS systems will be required throughout the region.

Aside from position monitoring, the ALC can be used for catch reporting, secure communications, and for safety. The ALC can give out a distress signal that identifies the boat and gives its position.



GMDSS — Global Maritime Distress and Safety System: is a system initiated by the International Maritime Organization (IMO) as part of the SOLAS Convention. GMDSS is designed to automate radio distress calls, eliminating the need for manual watchkeeping of distress channels. GMDSS uses a combination of VHF and HF radios, satellites, SARTs, and DSC, or digital selective calling. GMDSS can be very expensive as the system requires back-ups, or duplicates, of almost every device. The system has some inherent flaws and has been subject to numerous false alerts, especially with the DSC. Even though GMDSS became mandatory for SOLAS Convention vessels after 1 February 1999, IMO has recommended that vessels retain traditional radio communications, using VHF and HF radios for distress calling, until the year 2005.

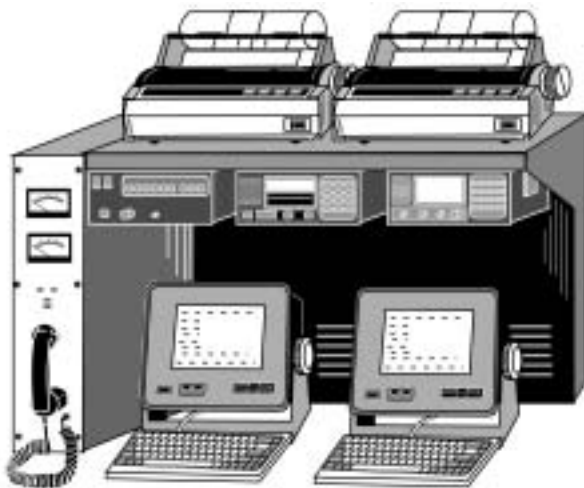

In any event, GMDSS applies only to commercial SOLAS Convention vessels over 300 GRT on international voyages. Commercial vessels under 300 GRT or those over 300 GRT on domestic voyages are subject to requirements of the flag state. Some flag states have incorporated GMDSS into their domestic regulations; other states have not. Most domestic long-line vessels operating in the WCPO will probably not be required to carry GMDSS equipment in the near future.

Maintenance

All electronic devices on a fishing boat require special care and maintenance. They should be kept dry and out of direct sunlight or other sources of heat. Sea spray should never be allowed to come in contact with electronics. If this does happen, however, the equipment should be cleaned and dried and then sprayed with silicone spray. All connections should be sprayed with silicone spray periodically. Most electronic devices will last longer if they are not switched on and off unnecessarily. Electronic devices that do not consume lots of power, such as radios and GPS, should be switched on at the beginning of each trip and switched off after the boat returns to port. Other devices, such as radar and echo sounders, can often be left on but in a standby mode.

I. VESSEL HYDRAULICS

Most longline systems are powered by hydraulics. Hydraulic systems convert mechanical energy into fluid energy and then back into mechanical energy. Hydraulic systems are a good way of moving power around on the deck of a boat. Workers do not have to worry about electric shock or getting caught on a shaft or pulley, although there are risks involved with hydraulic components. Other advantages of using hydraulic systems are: hydraulic motors can be started, stopped, or reversed under full load; hydraulic motors have high power for their size; and it is easy to regulate the power and speed of a hydraulic motor.

Basics

A hydraulic system consists of a tank or reservoir with hydraulic fluid, suction hose, pump, pressure hose, pressure relief valve, flow regulator, check valve, selector valve, control valve, motor or ram, return hose, cooling system and a filter. The pump is usually a vane pump that runs off the main engine, although it can be driven by an electric motor. If it is run off the main engine or an auxiliary engine it must be linked with pulleys and belts, gears, or a power take-off unit (PTO). If the pump is belt driven there is usually a mechanical or electrical clutch so the pump can be disengaged for emergency stops. PTOs usually have built-in clutches. A switch or lever to disengage the clutch for emergency stops is usually mounted somewhere in the wheelhouse or on an outside station on deck.

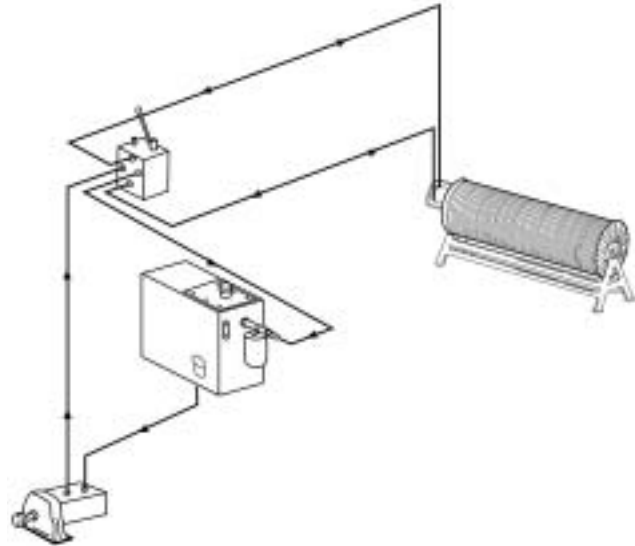

Hydraulic systems are rated by volume and pressure of fluid available for work. A typical longline system requires 15 gallons per minute (GPM) at 1200 PSI. The important thing is that the ratings of the pump match the requirements of the hydraulic motors or rams.

The pressure relief valve on a hydraulic longline system should be set so that it opens before the breaking strength of the mainline is reached. Even though a system has 1200 PSI of power available it should be adjusted to cut out at some lower pressure. The pressure relief valve can be adjusted by putting a load on the line at full power. The valve adjustment screw should be adjusted so that fluid dumps back into the return line or tank before the line breaks — actually just before the system reaches full power. This will save the mainline from breaking if it becomes tangled during hauling or if a large fish runs with the line.

Hydraulic rams or cylinders can be used for steering or on equipment such as a crane. Hydraulic motors on a longline boat are used for anchor winches, boom winches, capstans, line haulers, longline reels, longline setters, and line arrangers. One hydraulic pump can power more than one piece of equipment on a fishing boat, but usually not at the same time. The circuit of hoses may have one or more selector valves that divert the fluid from one system to another. The hydraulic motors used on large monofilament longline reels are usually radial piston motors while the hydraulic motors used on line setters are usually vane motors or linear piston motors. Radial piston motors usually need to have a case drain line that bleeds pressure from the motor case back into the return line.

Repairs and maintenance

Hydraulic oil must be clean and moisture free. Dirt and water can cause equipment failure. The best way to ensure that the hydraulic oil is clean is to change the filter on a regular basis. Inspection of the oil and filter should be a good indicator of whether the filter needs to be changed. If the oil is very dirty, then it should be changed, too. The entire system should be inspected regularly, including all hose ends and fittings, for corrosion and wear.

Hydraulic hoses and fittings on fishing boats often wear out or break, causing hydraulic oil to leak out on deck or into the bilge or lazarette. If the leak is noticed right away and the hydraulic system is stopped, then repairs can be made and the tank can be topped off with reserve hydraulic fluid.

Hoses and fittings on deck are subject to more wear and corrosion than elsewhere on a boat. The most common hydraulic repair at sea is to fix or replace a leaking hose. If a hydraulic hose springs a leak, it is time to replace the hose. However, if there are no spare hoses on board, a temporary repair can be done with reusable fittings. Two reusable female swivel hose-end fittings and a male adapter are needed. The easiest hoses to repair are non-skive hoses. This means that the hose does not have to be trimmed (skived). A hacksaw and two adjustable wrenches, or wrench and a vice, are the only tools needed.

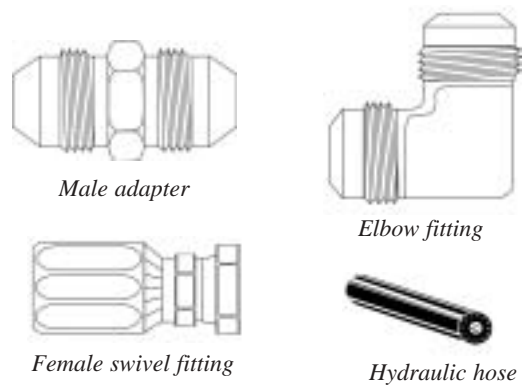

First, the hose is cut with the hacksaw on either side of the damaged portion so that there are two clean hose ends with straight 90° cuts. Next, a reusable female swivel fitting is attached to each hose end using the adjustable wrenches. The socket of the reusable fitting is screwed onto the hose first, with a left-hand twist using an adjustable wrench. Next, the tapered nipple of the fitting goes into the socket with a right-hand twist. The socket is held with one adjustable wrench and the tapered nipple is turned with the other adjustable wrench. This is done to both cut hose ends. The two resulting hoses are joined together by tightening the reusable fittings onto the adapter. In effect, the single broken hose becomes two separate good hoses, which are joined to make one.

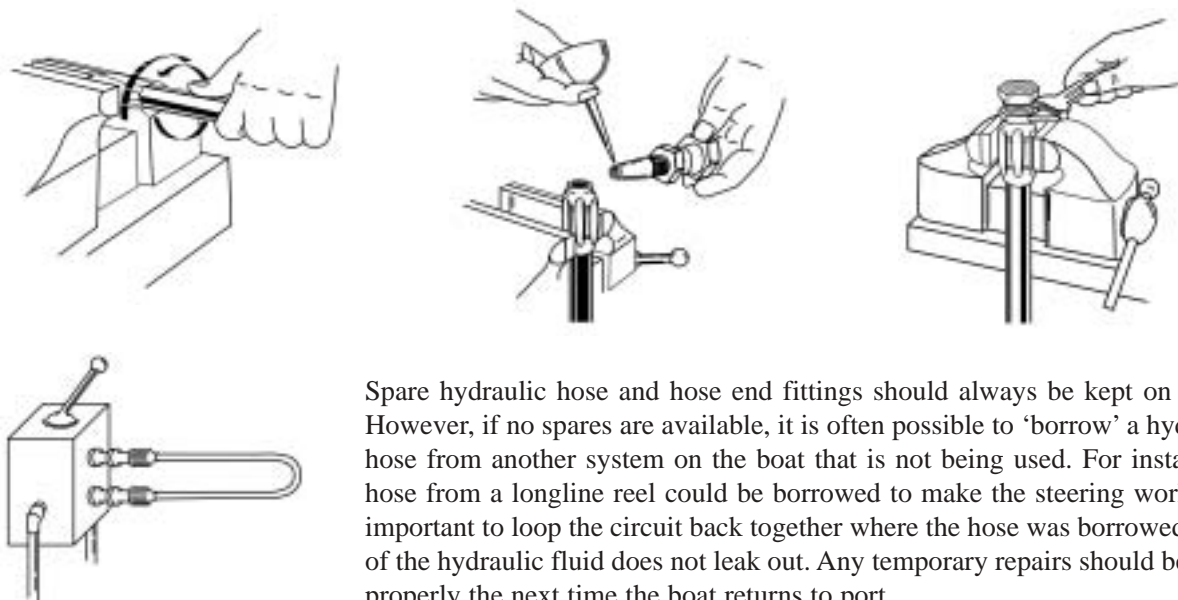

Spare hydraulic hose and hose end fittings should always be kept on board. However, if no spares are available, it is often possible to 'borrow' a hydraulic hose from another system on the boat that is not being used. For instance, a hose from a longline reel could be borrowed to make the steering work. It is important to loop the circuit back together where the hose was borrowed so all of the hydraulic fluid does not leak out. Any temporary repairs should be fixed properly the next time the boat returns to port.

Hydraulic hose ends and fittings that are not made of stainless steel will last longer if they are covered with a protective coating, such as Denso Tape or Soft Seal. Another good way to protect fittings is to spray them with cold galvanise paint. Cold galvanise can also be sprayed on hydraulic motors and valves. Before any part is sprayed with cold galvanise it should be treated. All rust should be chipped away and the part should be brushed with Ospho or some other rust inhibitor that contains phosphoric acid. After the acid reacts with the rust, a white powder forms. This should be brushed away with a wire brush. Lastly, the part is coated with cold galvanise. This process should be repeated regularly, possibly after every trip. Another way to protect hydraulic fittings is to wrap them in old inner tube rubber. On a fishing boat, this is called rubber wrapping. Old automobile inner tubes can be cut into strips about 6 cm wide. These strips can be used to make a watertight wrapping around fittings.

If all of the hydraulic fluid is lost from the system and there is no spare fluid, emergency hydraulic fluid can be made using motor oil and diesel fuel. Motor oil and diesel fuel are mixed in a ratio of about 80 per cent oil to 20 per cent diesel. The hydraulic system should be test run with the makeshift oil. If the hydraulic pump starts to overheat or appears to be running sluggishly, more diesel needs to be added to the mixture. If the hydraulic pump is racing or is not supplying enough power, more motor oil is needed. This makeshift hydraulic fluid should be replaced as soon as the boat returns to port.