

CAPTURE SECTION REPORT
OF
ASSISTANCE TO THE NATIONAL FISHERIES COLLEGE
KAVIENG, NEW IRELAND PROVINCE
PAPUA NEW GUINEA

15 JUNE 1998 – 29 JANUARY 1999

by

Peter Watt
Masterfisherman



© Copyright Secretariat of the Pacific Community 1999
The Secretariat of the Pacific Community authorises the production of this material,
whole or in part, in any form, provided that appropriate acknowledgement is given.

Original text: English

Secretariat of the Pacific Community Cataloguing-in-publication data

Watt, Peter

Capture Section Report of Assistance to the National Fisheries College
Kavieng, New Ireland Province Papua New Guinea / by Peter Watt

1. Fisheries—Papua New Guinea
 2. Fisheries—Study and teaching
 3. Fisheries schools—Papua New Guinea
- I. Title II. Secretariat of the Pacific Community

639.207095

AACR2

ISSN 1028-1134

ISBN 982-203-672-8

Secretariat of the Pacific Community
BP D5
98848 Noumea Cedex
New Caledonia

Tel.: (687) 26 20 00
Fax: (687) 26 38 18
e-mail: capture@spc.org.nc
<http://www.spc.org.nc/>

Prepared for publication at
Secretariat of the Pacific Community headquarters
Noumea, New Caledonia, 1999

Printed by Stredder Print, Auckland, New Zealand

ACKNOWLEDGEMENTS

The Secretariat of the Pacific Community (SPC) acknowledges with gratitude the cooperation provided by the administration and staff of the National Fisheries College, and in particular: the acting principal, Mr Melchar Ware; skipper and fishing master of FTV *Leilani*, Mr Kisi Geotau; fisheries technology specialists, Mr Camillus Kabinawedi and Mr Sato Nagashima; engineer, Mr Timothy Gewa; refrigeration specialist, Mr Simeon Akaar; post-harvest specialist, Mr Ronnie Tarat; boat builder, Mr Ambrose Guarim; and seamen, Mr Paul Kekes and Mr Naki Tami. SPC would also like to thank Mr Denise Renton, Executive Director of the National Fisheries Authority (NFA), and Mr L. Joel Opnai, Executive Manager of NFA, for their assistance during the Masterfisherman's visit.

The Secretariat also gratefully acknowledges the assistance of Mr Maurice Brownjohn, President of the Fishing Industry Association of PNG, for support throughout the project.

The author wishes to acknowledge the input provided by the SPC's Fisheries Development Adviser, Mr Lindsay Chapman, in setting up the project, providing field support throughout the project, and the technical editing and input provided in finalising this report.

The author is also grateful to all those involved in the production of this report, in particular, Ms Marie-Ange Roberts for the report format and layout, Ms Sarah Langi for the editing, and Ms Patricia Martin for the design of the cover. The author also thanks the SPC's Translation staff for translating the summary.

The Secretariat gratefully acknowledge the financial support of AusAid, who fully funded this project and the production of this report.

SUMMARY

Papua New Guinea has a large and diverse fisheries resource, generated by its productive Declared Fishing Zone (DFZ), over 2.4 million km² in extent, its extensive coastline, many islands and reefs, its large land mass, and its extensive inland waters. The fishing industry in PNG, although underdeveloped, has entered a new phase of dynamic growth. Recent policies implemented by the government are committed to increasing domestic participation in the fishing industry, in particular the offshore tuna industry, and to encourage investment from the private sector. However, a major constraint to the domestication of the offshore tuna fishery and development of the commercial fishing industry in general, is a lack of skilled manpower. To meet the needs of the expanding fishing industry the National Fisheries Authority, with input from the Fishing Industry Association of PNG established an industry-related modular training programme in 1997. This modular training programme was implemented through the National Fisheries College (NFC) in Kavieng and the Maritime College in Madang.

In June 1998, SPC Masterfisherman, Peter Watt, was assigned to NFC for eight months to provide technical assistance in the training of students in fishing technology and fishing operations. The responsibilities of the Masterfisherman were to train the students at NFC in various coastal and offshore fishing techniques, on board fish handling techniques, basic navigation and seamanship skills. During this visit, two groups, each of eighteen students, completed the Fishing Technology training module.

In each group, the students were trained in the fabrication and use of various fishing gears including trolling lines, vertical droplines, bottom-fishing handreels, handlines, tuna long-line, gillnets, beach-seine and prawn trawl. The technical skills required for each fishing gear were demonstrated during 'hands-on' fishing operations. These skills included identification of the fishing area, deployment and retrieval methods, repair and storage of gear. Catch handling techniques in gaffing, killing, bleeding, gilling and gutting, and brining were also taught during fishing operations.

Twenty-eight fishing trips were completed, 15 by the first group and 13 by the second. Total catch for the fishing operations of both groups was 6,675 kg. Catches for each fishing method were: trolling 464 kg; vertical dropline 324 kg; handreel 1,201 kg; handline 756 kg; tuna long-line 3,765 kg; gillnet 5 kg; beach-seine 160 kg; and prawn trawl nil (demonstration only).

A training manual in fishing gear technology was designed to assist the tutors in teaching the students the fabrication of the fishing gears. The manual consisted of illustrations and descriptions of the methods for fabricating each fishing gear used in the fishing operations, and included various rope knots and splices.

An offshore Fish Aggregating Device (FAD) was deployed 12.5 nm northwest of Kavieng Harbour. An extensive bottom contour survey was conducted using the NFC training vessel, FTV *Leilani*, to locate a suitable FAD site. The FAD was rigged and deployed with assistance from the FTV *Leilani* crew and students. Two good catches of tuna were caught around the FAD during the second training session. Unfortunately, the FAD was lost 4 months after deployment, assumed to have been cut loose by 'rascals'.

RÉSUMÉ

La Papouasie-Nouvelle-Guinée dispose de ressources halieutiques aussi vastes que diversifiées, grâce à sa zone de pêche déclarée aux eaux abondantes, qui s'étend sur plus de 2,4 millions de km², à son littoral étendu, à ses nombreuses îles et ses récifs, à sa grande masse continentale et son réseau de voies d'eau intérieures. Bien qu'elle soit encore peu développée, l'industrie de la pêche de PNG aborde une nouvelle phase de croissance dynamique. Le gouvernement a récemment pris des mesures visant à accroître la participation de ses ressortissants à cette filière, notamment la pêche thonière hauturière, et à inciter le secteur privé à investir. Or, la pénurie de main-d'œuvre qualifiée constitue un obstacle de taille à la montée en puissance d'une industrie nationale de la pêche thonière hauturière et, plus généralement, à l'essor de la pêche industrielle. En 1997, avec le concours de l'Association des professionnels de la pêche de PNG, l'Office des pêches de PNG a mis en place un module de formation pratique afin de répondre aux besoins générés par l'expansion de ce secteur. Ce programme a été mis en œuvre par l'École des métiers de la mer (NFC) de Kavieng et le Collège maritime de Madang.

En juin 1998, Peter Watt, maître de pêche à la CPS, a été détaché auprès de la NFC pour une mission de huit mois, afin d'apporter une assistance technique à l'École et de former des étudiants à la technologie et aux méthodes de pêche. Il a été chargé de leur enseigner diverses techniques de pêche côtière et hauturière, les méthodes de manipulation du poisson à bord, les principes de la navigation et le matelotage. Durant cette mission, deux groupes de dix-huit étudiants chacun ont suivi le module "Technologie de la pêche".

Les étudiants de chaque groupe ont été initiés à la fabrication et à l'utilisation de divers engins de pêche : lignes de traîne, lignes dormantes verticales, moulinets de lignes de fond, palanquettes, palangres de pêche au thon, filets maillants, sennes de plage et chaluts de pêche à la crevette. Au cours de travaux pratiques, les étudiants ont pu acquérir les compétences techniques requises pour chacun des engins de pêche : identification de la zone de pêche, méthodes de mouillage et de récupération des engins, réparation et stockage des engins. Ils se sont exercés aux techniques de manipulation de la prise : comment gaffer le poisson, le tuer, le saigner, l'éviscérer, retirer les branchies et le plonger dans la saumure.

Au cours de 28 sorties de pêche – 15 pour le premier groupe, 13 pour le second – les deux groupes ont capturé 6 675 kg qui ont servi aux travaux pratiques. Cette prise se répartissait comme suit, selon la méthode appliquée : pêche à la traîne 464 kg; ligne dormante verticale 324 kg; moulinet 1 201 kg; palanquette 756 kg; palangre 3 765 kg; filet maillant 5 kg; senne de plage 160 kg et chalut à crevettes néant (démonstration seulement).

Un manuel de formation à la technologie des engins de pêche a été rédigé pour aider les instructeurs à enseigner la fabrication des engins de pêche. Ce manuel illustré décrit les méthodes de fabrication de chaque engin utilisé au cours des travaux pratiques ainsi que différents nœuds et épissures.

Un dispositif de concentration du poisson (DCP) de haute mer a été mouillé à 12,5 milles au N.O. de Kavieng Harbour. Une étude bathymétrique précise a été effectuée à bord du bateau-école de la NFC, le *Leilani*, afin de trouver un site de mouillage adéquat. L'équipage du *Leilani* et les étudiants ont aidé à assembler et déployer le DCP. Au cours de la seconde session de formation, deux bonnes prises de thon ont été réalisées autour du DCP. Malheureusement, celui-ci a disparu, quatre mois après son mouillage, probablement détaché par des "voyous".

CONTENTS

1.	INTRODUCTION	1
1.1	Papua New Guinea and New Ireland Province	1
1.2	Papua New Guinea Fisheries	2
1.3	National Fisheries College	3
1.4	Fishing Cadet Course	4
1.5	Consultant Masterfisherman visit to NFC	5
1.6	Project initiation	6
2.	INFRASTRUCTURE	7
2.1	National Fisheries College campus and equipment	7
2.2	The NFC training vessel FTV <i>Leilani</i>	8
3.	TUTORIALS AND FISHING OPERATIONS	9
3.1	General	9
3.2.	Trolling	10
3.2.1	Fabrication of gear	10
3.2.2	Fishing operations	11
3.2.3	Catch and effort	11
3.3	Vertical dropline	12
3.3.1	Fabrication of gear	12
3.3.2	Fishing operations	12
3.3.3	Catch and effort	12
3.4	Bottom handreel and handline	13
3.4.1	Fabrication of gear	13
3.4.2	Fishing operations	14
3.4.3	Catch and effort	15
3.5	Tuna longline	16
3.5.1	Fabrication of gear	16
3.5.2	Fishing operations	17
3.5.3	Catch and effort	18
3.6	Net fishing	19
3.6.1	Fabrication of gear	19
3.6.2	Fishing operations	21
3.6.3	Catch and effort	22
3.7	Fish processing	23
3.8	Data collection	23
3.9	Disposal of catch	24
4.	CATCH AND EFFORT SUMMARY	24
5.	SPECIES COMPOSITION OF THE CATCH	24
6.	OTHER ACTIVITIES	25
6.1	FAD deployment	25
6.1.1	Introduction	25
6.1.2	FAD site survey	25
6.1.3	FAD assembly and rigging	26
6.1.4	FAD deployment procedures	29
6.1.5	Results	29
6.2	Fishing gear technology training manual	29

7.	CONCLUSIONS AND RECOMMENDATIONS	30
7.1	General conclusions	30
7.2	Specific conclusions	30
7.3	Recommendations	33
8.	REFERENCES	34
APPENDICES		
A	Specifications of FTV <i>Leilani</i> and the electronics on board	37
B	Repairs undertaken on FTV <i>Leilani</i> during this assignment	39
C	Catch data for fishing operations by fishing method	41
D	Data collection forms	45
E	Species composition of the vertical dropline and bottom handreel catch	47
F	Species composition of the troll and longline catch	49

1. INTRODUCTION

1.1 PAPUA NEW GUINEA AND NEW IRELAND PROVINCE

Papua New Guinea (PNG) extends from the equator to 12° S latitude, and from the Irian Jaya border in Indonesia to 160° E longitude (Figure 1). The total land area is approximately 476,500 km²; it is the largest island country in the South Pacific. There is over 8,300 km of coastline and the Declared Fishing Zone (DFZ) is approximately 2.4 million km² (Figure 1). The present population of PNG is 4.2 million with more than one third of the people living in the highland provinces. The people of PNG are related to people from other parts of the Pacific. They include the descendants of the Papuan people; Melanesians who are closely related to the islanders of Fiji, Vanuatu and New Caledonia; Polynesians related to Samoans, Tongans and Tahitians; and Micronesians, related to the people of the Marshall Islands, Kiribati, and Nauru. More than 700 languages are spoken in PNG, about one-third of the world's indigenous languages. The main languages used for communication throughout the country are English, Tok Pisin and Hiri Motu (Lipscomb et al., 1998).

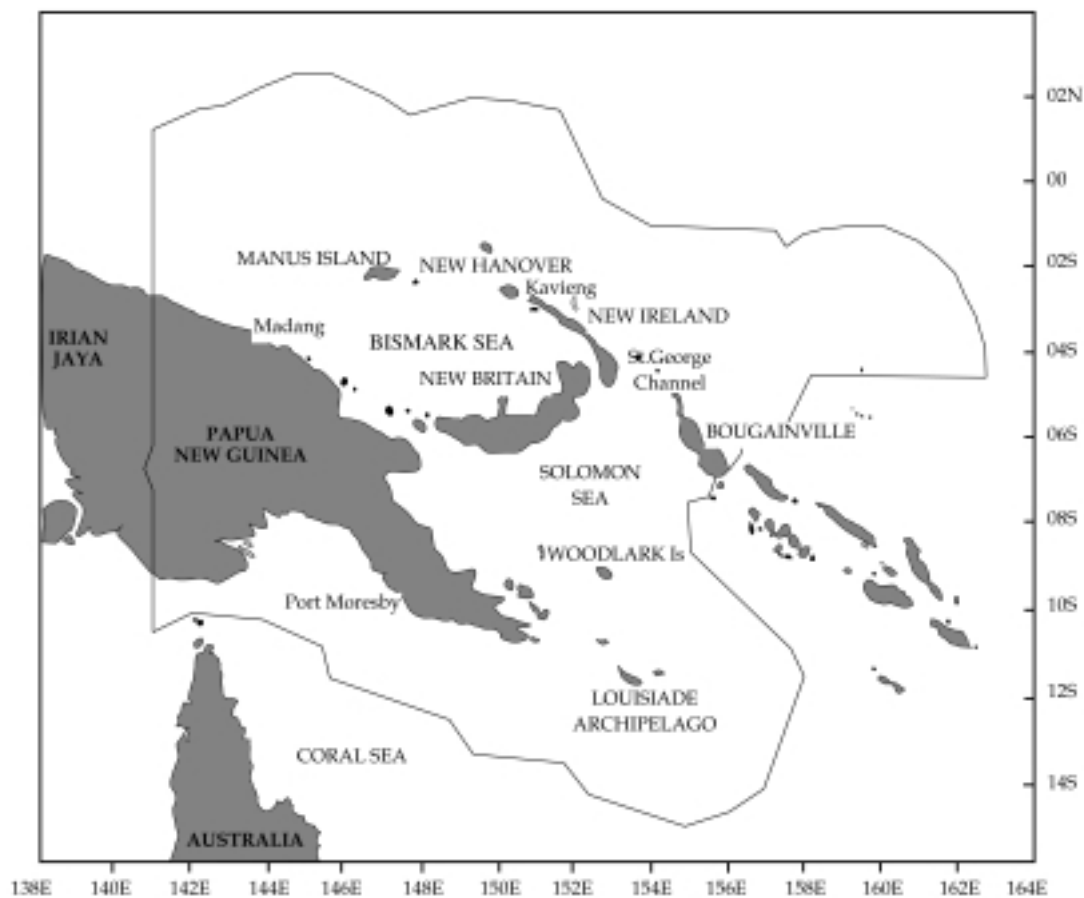

Figure 1: Map of Papua New Guinea showing the Declared Fishing Zone

New Ireland Province is a group of 149 islands north of New Britain. The total land area is approximately 9,600 km² and the population is over 100,000. The province is spread over 230,000 km² of sea. The equator marks the northern extremity of the province's boundary and 5° S latitude marks the southern boundary. The main island, New Ireland, is 350 km long and only 10 km wide, with a mountain range falling straight to the sea on most of the west coast. The climate is fairly wet especially in the south. The people of New Ireland are Melanesian and 19 different languages are spoken. Kavieng is the capital with a population of 7,000. It is situated at the northeastern tip of New Ireland Island. Kavieng receives 300 cm of rainfall annually, and has a dry season between May and November. After the volcanic eruption in Rabaul in 1994 many people, expatriates and locals, fled and settled in Kavieng (Lipscomb et al., 1998).

The domestic fisheries sector in Papua New Guinea is underdeveloped. The main activity occurs at the subsistence level where approximately 600,000 coastal and inland people harvest a wide range of marine species. Coastal subsistence production is estimated at 15,000–20,000 mt per annum, while inland fish production is estimated at 10,000 mt. Artisanal fisherman catch and market approximately 3,000 mt per annum. Larger-scale domestic commercial fishing operations, consisting of prawn trawling, shark fishing, tuna longlining and purse-seining, catch approximately 60,000 mt. The country imports and consumes about 40,000 mt of canned fish and 1,000 mt of processed and whole fish. The total per-capita consumption of fisheries products is approximately 18 kg per annum. At present, the fisheries sector plays a minor role in the economy, contributing less than one per cent to gross domestic production (Anon., 1995).

The actual potential in the sector is very substantial, with sustainable annual fish yields approaching 700,000 mt. However, the majority of the fisheries resources are not exploited. The reasons for this are numerous and include: lack of fishing tradition; insufficient skills; lack of motivation; poorly developed infrastructures; lack of support services, marketing and distribution networks; and poor access to domestic and international markets. Other factors include import tariffs on essential materials, duties on exports, taxes on fuel, high interest rates and high domestic airfreight charges.

There is a large foreign fishing industry in PNG waters. Commercial tuna fishing began in the 1950s with Japanese longliners, followed by the Taiwanese and Koreans in the 1960s and 1970s respectively. In the longline fishery the highest estimated catch was 19,500 mt in 1978. A locally based joint venture between Japan and PNG resulted in a pole-and-line fleet being established in New Britain and New Ireland during the 1970s. The catches from the Japanese and PNG pole-and-line vessels during the 1970s reached 90,000 mt at its peak (Lawson, 1996), of which nearly 50,000 mt was landed by domestic vessels before catches declined and operations ceased in 1981. Since that time foreign vessels from the United States, Korea, Taiwan, Vanuatu and the Philippines have been licensed to purse-seine for tuna in PNG's offshore waters. Presently, there are approximately 100 foreign purse-seine vessels licensed to fish in PNG waters. Annual catches have ranged from 200,000–300,000 mt in recent years at a total value of about K 200 million (Anon., 1996a). The revenue derived from the foreign fishing fleets, which is approximately 6 per cent of the value of the catch, is meagre when compared to the actual fish catch (Anon., 1996b; Anon., 1998).

Currently, employment in the commercial fisheries sector is limited to positions on prawn trawl, tuna longline and purse-seine vessels, lobster harvesting, a few coastal fishing operations, canneries, marketing and administration activities. An estimated 1,000 persons are gainfully employed in the industry. Employment in the prawn trawl fishery is limited as the fleet can not expand beyond 15–20 vessels due to resource limitations and conflicts with inshore fishermen. There are now 15 prawn trawlers operating in PNG; the annual catch is about 800 mt valued at K 20 million.

The tuna fishery is the industry that holds the most promise for employment. A fishery development plan produced in 1995 in anticipation of an Asian Development Bank loan, envisaged that the domestic tuna fleet would grow to 300 longline vessels and 10 purse-seiners by the year 2005. In addition, most of the foreign licensed purse-seiners would be based in PNG, landing fish at canneries in Madang, Lae and Milne Bay. An estimated 2,000 crewmen would be employed on the vessels and the three canneries would provide jobs for over 1,000 women and a few hundred men. At present, there are about 25 domestic tuna longliners fishing in PNG waters, the annual catch is about 2,500 mt valued at K 25 million. There are 16 domestic purse-seiners licensed to fish in PNG; 12 are operating full-time. The annual catch is about 50,000 mt valued at K 22 million (Cecily, unpublished).

Some 2,000–3,000 artisanal fishermen regularly earn cash incomes from the supply of fish to local markets. In addition, several hundred divers derive occasional income from harvesting reef and shoreline species such as trochus, lobster, beche-de-mer, mangrove crab, green snail, oysters and other shell products.

Overall, there is a total labour force in the fisheries sector approaching 4,000–5,000 persons, most of which is comprised of part-time fishers. The potential exists for several tens of thousands of jobs in the catching, processing, marketing and administration of the fishery resource. The gradual domestication of the offshore tuna fisheries, and the development to sustainable-yield levels of the coastal and inshore fisheries and marine resources would ensure the creation of employment opportunities for PNG nationals (Cecily, unpublished).

1.3 NATIONAL FISHERIES COLLEGE

Commercial fishing started in the Kavieng area in 1970 when the Golling Kyokuyo Fishing company began fishing with three, 30 gross ton pole-and-line vessels and a mothership. By 1971 Golling Kyokuyo expanded its operation to include 20 pole-and-line vessels based in Kavieng and a smoked skipjack, (arabushi and katsuobushi), factory situated on Nago Island. The fleet was landing an estimated 50,000 mt by the late 1970s. The factory on Nago Island processed approximately 2,000 mt of raw tuna per annum. The remaining raw fish were exported direct by mothership to Japan (Anon., 1981).

In 1977 the National Fisheries College (NFC) was established to provide training programmes which catered to the domestic pole-and-line industry. The pole-and-line fishery was closed in 1981, due to restricted access to the tuna resources and the falling fish prices. Subsequently, NFC was forced to revise the course syllabus. The college developed a two-year certificate course, Certificate in Tropical Fisheries, which was oriented to provide training for extension officers and generalists for the fisheries sector. Table 1 provides an outline of the syllabus for this certificate course.

Table 1: Syllabus content of Certificate in Tropical Fisheries

Syllabus	Year I	Year II
General Studies		
Applied Mathematics (Fisheries)	108 hours	
Applied Science	108 hours	
English	108 hours	
Supplementary Maths (as required)		
Marine & Fish Biology	108 hours	108 hours
Ocean & Aquatic Ecology	108 hours	
Practical Aquatic Field Work	108 hours	
Fisheries Business Management		108 hours
Fisheries Law & Surveillance		108 hours
Technology		
Fishing Technology	216 hours	216 hours
Seamanship & Navigation	216 hours	
Seafood Technology	216 hours	
Fishing Craft & Engine Maintenance	108 hours	216 hours
Mechanics & Refrigeration		216 hours
Practical Fishing Operations	216 hours	216 hours
Options		
Seamanship & Navigation		216 hours
Seafood Technology		216 hours

As the domestic fishing industry grew through the 1980s and 1990s it became apparent that the Tropical Fisheries Course was inappropriate and did not provide adequate training in the technical skills required for the commercial fisheries sector. Reviews in 1989 (United Nations Development Programme—UNDP), 1990 (Asian Development Bank—ADB), 1992 and 1993 (Japanese International Cooperation Agency—JICA) recommended that the NFC syllabus be changed to meet fishing industry needs. Some changes were made in the syllabus in the early 1990s, but further reviews by ADB in 1994 and 1995 found that the changes were still not sufficient to provide the vocational skills required for the industry. The ADB review team recommended that a radical change was required to meet the needs of the industry because employment opportunities for PNG nationals in the commercial sector were dependent upon the availability of appropriately trained and qualified people. In response to these recommendations, the National Fisheries Authority (NFA), with input from the Fishing Industry Association of PNG, established an industry-related modular training programme in 1997 (Anon., 1998; Ware, unpublished).

1.4 FISHING CADET COURSE

The modular Fishing Cadet Course was designed to meet minimum performance and competency standards as set by the International Maritime Organisation (IMO) under the 1995 Convention of Standards of Training and Certification and Watchkeeping (STCW). A version of STCW that relates specifically to fisheries (STCW-F) has been proposed by the IMO. SPC is currently developing a Pacific Islands Qualified Fishing Deckhand standard and this standard will be at a similar level to STCW-F. The training provided in the Fishing Cadet Course was designed to enable graduates to meet both standards.

The course designed for fishing cadets consists of three training modules with a duration of three months each. The first module is held at the PNG Maritime College in Madang. The college provides training in a Pre-Sea Induction (STCW 95 Requirements) module. Graduates who successfully complete the course, receive a Seaman Certificate with competency certificates in first aid, survival at sea, firefighting and Deck and Engine Rating 2. These certificates qualify the graduates to be employed on a commercial vessel in PNG.

The second module, Fishing Technology, is held at the NFC in Kavieng. The course syllabus includes training in basic fishing gear technology, fishing operations, seafood technology, refrigeration, mechanics, and carpentry skills as summarised in Table 2. Special emphasis is placed in the training of practical skills required for the main commercial fisheries in PNG: prawn trawl, purse-seine and tuna longline. Onshore practical training sessions are designed to train the students in the fabrication of various fishing gears. The majority of the sessions focus on the fabrication and repair of nets and tuna longline gear.

Table 2: Syllabus of NFC Module 2—Fishing Technology

Subject	Content
Commercial Fishing Introduction	Overview of the Fishing Industry and Commercial Fishing Activities in PNG and Pacific region (emphasis on purse-seine, tuna longline and prawn trawl fisheries).
Fishing Gear Technology	Gillnet, beach-seine and prawn trawl (fabrication and repair), tuna longline (fabrication and repair), surface trolling gear (fabrication), vertical dropline (fabrication), and bottom terminal rig (fabrication).
Fishing Operation	Practical fishing at sea (tuna longline, trolling, vertical dropline, bottom handreel and handline, beach-seine, gillnet, prawn trawl). Fishing vessel equipment (electronic and mechanical).
Refrigeration and Mechanics	Basic refrigeration, electrical systems, maintenance, storage, workshop safety, tools and equipment, welding.
Seafood Technology	Spoilage autolysis, bacteria oxidation, traditional methods for controlling spoilage, freezing, hygiene.
Fishing Craft	Craft selection, craft maintenance, stability principles, tools and equipment, carpentry skills, workshop safety.

The third module is an Industrial Attachment where the students are assigned to commercial fishing companies based at various locations throughout the country. During the attachment it is expected that the students gain some 'hands-on' experience and apply skills learned in the first two modules to assist in fishing operations.

The fourth module is held back at the NFC. It is a two-week course on Fisheries Legislation and Regulations in PNG.

The students are tested and evaluated throughout the course to determine the level of their competency and understanding of the theory and skills taught by the tutors. Managers of the companies where the students are assigned during their Industrial Attachment also evaluate the student's competency. Students who successfully complete the four modules receive a 'Fishing Technology Certificate'.

1.5 CONSULTANT MASTERFISHERMAN VISIT TO NFC

The revision of the training programme from the two-year Certificate in Tropical Fisheries to an industry-related, nine-month modular course for fishing cadets required technical expertise to train the students to a skill level of sufficient standard to work in the commercial fishery. As the main focus of the course was to train students in practical fishing skills and expose them to 'hands-on' fishing experience, the NFA decided to recruit the services of a consultant Masterfisherman with known skills in tropical fishing methodologies.

Masterfisherman consultant, Mr Paxton Wellington, who previously worked for the SPC, was recruited by NFA from 8 May to 7 November 1997, to provide training in various commercial fishing methods and develop instructional materials for NFC. The terms of reference for the Masterfisherman consultant were to:

- Provide on-the-job advice and assistance in the operation of the NFC Training Vessel, FTV *Leilani*;
- Act as fishing master of the NFC Training Vessel FTV *Leilani*;
- Assist in the development of Fishing Operations Curricula;
- Assist in the training of staff and students in Fishing Technology and Fishing Operation skills; and
- Report on the activities undertaken during the course.

The consultant Masterfisherman assisted NFC for two, three-month fishing technology modules with twenty students enrolled in each module. Unfortunately, he spent a substantial amount of time during his visit repairing the FTV *Leilani* (Wellington, unpublished).

Fishing operations during the two fishing cadet modules included trolling, vertical dropline, bottom handreel and handline, tuna longline, gillnet, beach-seine, dip net and prawn trawl. The Japanese Overseas Volunteer Cooperation (JOVC) Masterfisherman, Mr Suzuki, assigned to NFC for two years, was responsible for the net fishing operations while Mr Wellington was responsible for the other operations.

It was reported that the fish catches throughout both courses were disappointing. Although there were no records of bottom fishing catches, fishing was very poor, even in areas which were thought to be rarely fished by local fishermen. Catches while trolling around an open-water FAD proved to be inconsistent. During the first session from May to August 1997 it was possible to catch an average of one hundred small tuna around the FAD but during the second session, catches were down to five or six fish. Tuna longline catches were also poor. It was speculated that the poor catches possibly were due to the 'El Nino' event changing the migratory patterns of the tuna (Wellington, unpublished). A total of 16 longline sets were completed during the two courses. Results of the tuna longline sets are recorded in Table 3.

Table 3: Results of tuna longline catches from May to October 1997

Fish Species	No. of Fish	No. of Hooks	No. of Sets	Total weight
Yellowfin	21	200/set	16	615 kg
Marlin	6	200/set	16	86 kg 5 fish not recorded
Sailfish	6	200/set	16	49 kg 4 fish not recorded
Swordfish	6	200/set	16	6 fish not recorded
Total	39	3,200	16	750 kg with 15 fish not recorded

No records could be found of the fishing operations or catches for the net fishing operations.

Upon completion of the two Fishing Cadet training modules the consultant Masterfisherman made the following recommendations:

- That a Masterfisherman be recruited full-time to conduct practical fishing operations and be responsible for the maintenance of the FTV *Leilani*;
- That additional tuna longline gear be purchased for the training vessel as this would give the students a more realistic exposure to commercial longline fishing operations and catches would be higher;
- That the syllabus include more training in commercial fishing methods; and
- That the grading of the students be more stringent to ensure that the students were competent in the skills required to work in a commercial fishing operation.

1.6 PROJECT INITIATION

The PNG NFA in September 1996 requested assistance from the Australian Agency for International Development (AusAID) to support a project to improve the availability of appropriately trained Papua New Guinean nationals to participate in and promote the development of the fisheries sector. The objectives of the project were to: develop the institutional capacity of the NFC to meet the needs of the rapidly growing commercial fisheries sector; develop appropriate courses to meet industry needs and national competency accreditation; refurbish some of the existing facilities; and construct a new Post-Harvest Seafood Centre. Australian inputs would also include two long-term advisers; a team leader, fisheries specialist and manager for a period of four years; and a Fishing Master Adviser for a period of three years. There were also short-term adviser positions. The funding requirements for the project were estimated at AUD \$5.5 million. It was projected that the project would start at the beginning of 1998.

The project was delayed due to the reallocation of AusAID funds to assist PNG nationals living in areas severely affected by a drought caused by the 'El Nino' event in 1997. The NFC found itself without a Fishing Master to coordinate the fishing operations for the Fishing Cadet Courses. Subsequently, a request from the NFA on behalf of the NFC was submitted to the SPC for the services of a Masterfisherman. The terms of reference for the Masterfisherman were to:

- Train students enrolled in the Fishing Cadet Course at NFC in various offshore fishing techniques including tuna longlining, deep-water snapper fishing and other techniques as required by the course curriculum;

- Train the students in on-board handling practices of the catch, basic navigation and seamanship skills;
- Act as Fishing Master on board the college's vessel FTV *Leilani* for the practical fishing components of the course;
- Assist in the production of a manual on different fishing techniques;
- Produce a report of the activities of the project; and
- Meet with senior staff of NFA for briefing and debriefing at the commencement and conclusion of the project.

In response to the NFA request, SPC Masterfisherman Mr Peter Watt was assigned to assist the NFC in the running of the second module of the Fishing Cadet Course in Kavieng. He commenced this assignment on 15 June 1998 with the project concluding on 29 January 1999.

2. INFRASTRUCTURE

2.1 NATIONAL FISHERIES COLLEGE CAMPUS AND EQUIPMENT

The NFC main campus is located about 5 km south of Kavieng near Kopkop. There is also a waterfront facility located on Kavieng Harbour. Facilities on the main campus for training students and housing staff include the following:

1. Office complex including administration office, principal's office, 9 staff offices, conference room, staff room and library;
2. Staff accommodation including 24 two- and three-bedroom houses;
3. Four dormitories including 72 rooms and washing facilities;
4. Auditorium;
5. Classroom complex including two large classrooms, net loft, canteen and storage room;
6. Kitchen and mess hall;
7. Post-harvest facility including fish-processing plant, three electrical freezers, one walk-in deep-freeze unit and storage room;
8. Workshop including table saw, drill press, storage for carpentry and plumbing supplies; and
9. Recreation hall.

Facilities at the NFC waterfront area include the following:

1. Large workshop including table saw, drill press, planer, 4 work benches with vices, 2 metal working lathes (not functioning), electrical welder, acetylene metal cutter, various carpentry and welding tools, two storage areas, and one air compressor;
2. Outboard engine repair shop including work bench with vice, three storage rooms, repair room and three Yamaha outboard engines (9.9, 25 and 55 hp);
3. Wharf for the FTV *Leilani* and two 6 m fibreglass Yamaha 'banana' boats. At the time of the project, there were also three Taiwanese longline vessels which had been confiscated by the PNG government for illegally fishing within their DFZ, tied to the end of the wharf;

4. Net loft; and
5. Slipway with diesel engine boat hauler.

NFC provided support staff, including a skipper and crew of the FTV *Leilani*, operating costs for the training vessel (fuel, bait, ice, maintenance and provisions), accommodation, office facilities and transport for the SPC Masterfisherman. Also, one of the confiscated vessels' freezer holds was used to store bait and make ice.

2.2 THE NFC TRAINING VESSEL FTV *LEILANI*

The NFC training vessel, FTV *Leilani* (Figure 2) was built in Taree, New South Wales, Australia in 1994 under funding provided by the European Union. The hard-chine, semi-planing hull was fabricated from fibreglass-reinforced plastic (FRP). The vessel was designed and outfitted for multi-purpose fishing (Figure 3) in a tropical marine environment. Specifications of the FTV *Leilani* are given in Appendix A.



Figure 2: The FTV *Leilani* moored at the college wharf

The FTV *Leilani* came equipped from Australia with an array of fishing gear and electronic equipment to enable it to be used for a variety of fishing methods for training purposes. A list of the wheelhouse electronics is given in Appendix A.

The vessel was designed to perform a number of different fishing operations. It was equipped with a Ziegra-Eismaschwen salt-water ice machine, Leahy 7 nm capacity longline drum, line shooter, branchline hauler, longline guide, net drum, 2 trawl winches, transom roller, trap hauler, 1 t capacity fish hold, salt-water live fish hold, three steering stations, and deck wash pump.

To accommodate students and crew for multiple day fishing trips the vessel was well equipped with sleeping bunks for 9 people, cooking and washing facilities, refrigerator, and toilet. During this visit, many repairs were undertaken on board FTV *Leilani*, with these listed in Appendix B.

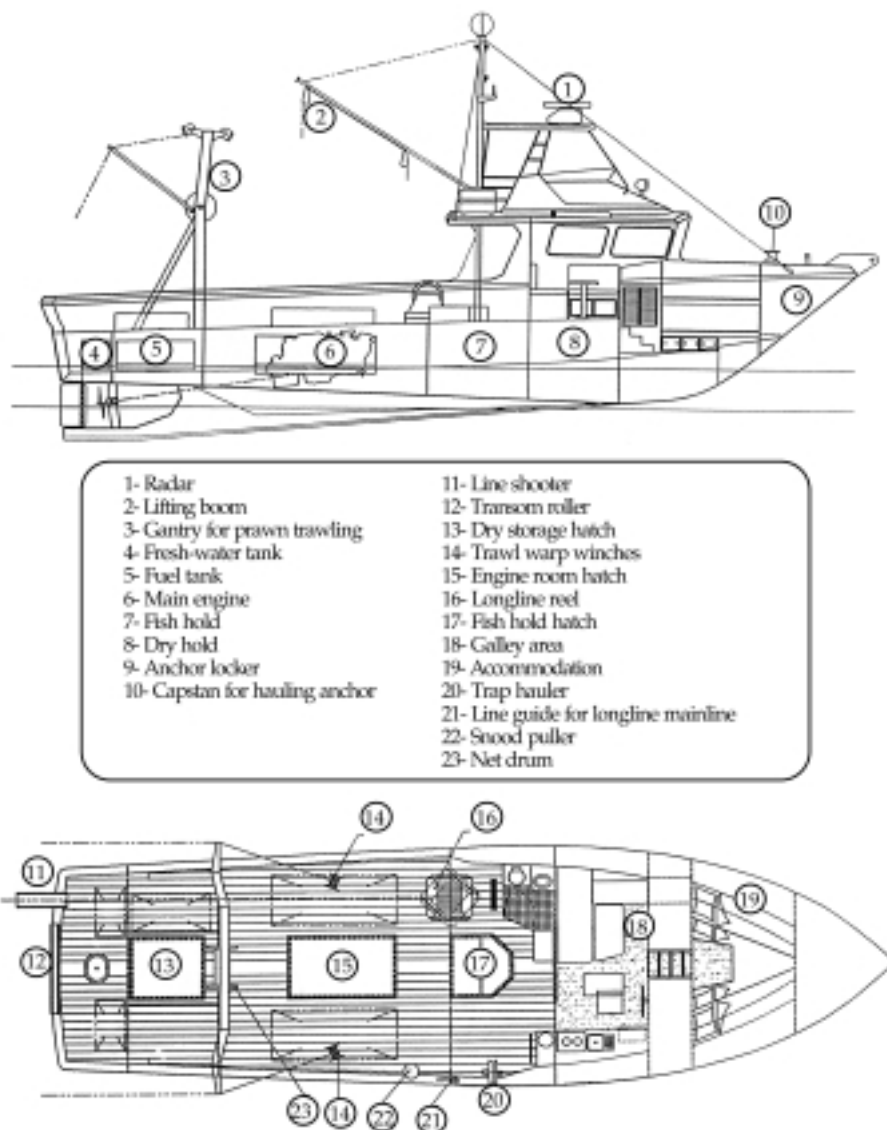

Figure 3: The FTV Leilani, side profile and deck plan

3. TUTORIALS AND FISHING OPERATIONS

3.1 General

Twenty students were enrolled in each of the three-month Fishing Technology training sessions at the college. Four withdrew before completing the course. The students came from every province in the country including four from the Highlands who had never been to sea. Also, there were five women, three in the first group and two in the second group.

For each training session the students were split into two groups. Each week for a three-month period, one group was taught the fabrication of fishing gear then went to sea for fishing operations while the other group remained ashore to learn theoretical and practical skills in seafood technology, carpentry, refrigeration and mechanics. The groups alternated weekly between going to sea and remaining ashore.

The students were exposed to as many fishing techniques as possible during the short, three-month course. Particular emphasis was placed on the teaching of practical skills required for the main commercial fisheries in PNG. Most of the onshore training in fishing technology focused on the fabrication of nets and tuna longline gear.

A comprehensive fishing operation schedule was designed to ensure the students spent as much time as possible at sea to learn the skills required for each fishing method. Figure 4 shows the area fished around Kavieng by the students; the schedule for the fishing methods used during each training sessions is outlined in Table 4.

Table 4: Schedule for each fishing method

Training Period	Fishing Methods
Weeks 1 & 2	Trolling for pelagic species and vertical dropline for bottom fish species
Weeks 3 & 4	Trolling for pelagic species and deepwater handreel for bottom fish species
Weeks 5 & 6	Tuna longline fishing
Weeks 7 & 8	Gillnet and handline fishing
Weeks 9 & 10	Beach-seine, prawn trawl, and handline fishing

A rigid work programme was followed every week for the fishing operations. Most of the operations consisted of two days and one night at sea. Occasionally the schedule was altered when the FTV *Leilani* had to return to port after one day of fishing due to a shortage of ice, the fish hold being full, or mechanical breakdowns. If possible, the FTV *Leilani* continued fishing operations the following day. The weekly training programme for fishing operations is outlined in Table 5.

Table 5: Weekly schedule for fishing operations

Monday	Theoretical lectures on fishing technology
Tuesday	Fishing gear fabrication, preparation of FTV <i>Leilani</i> for fishing operations
Wednesday	Demonstration and training in the use of fishing gear
Thursday	Same as Wednesday
Friday	Vessel clean-up, repair and maintenance of fishing gear

3.2 TROLLING

3.2.1 Fabrication of gear

The students were trained to fabricate fixed trolling lines to attach to the transom and trolling booms of the FTV *Leilani*. Each trolling line consisted of a trace, to which an artificial lure was attached, a mainline, used to distance the lure from the boat and a backing cord with a shock absorber. The trace was fabricated from either 10 m of 100 kg test monofilament line or a 2 m length of multistrand wire attached to an 8 m length of 50 kg test monofilament line. An octopus lure with a double stainless steel hook was attached to one end of the trace and the mainline with a barrel swivel attached to the other. The mainline consisted of 30–50 m of 6.4 mm braided tarred kuralon rope. The mainline was attached to the backing with another barrel swivel. The backing consisted of a 2 m backing cord of 8 mm polypropylene rope tied to a shock absorber fabricated from rubber strips cut from an inner tube (Figure 5).

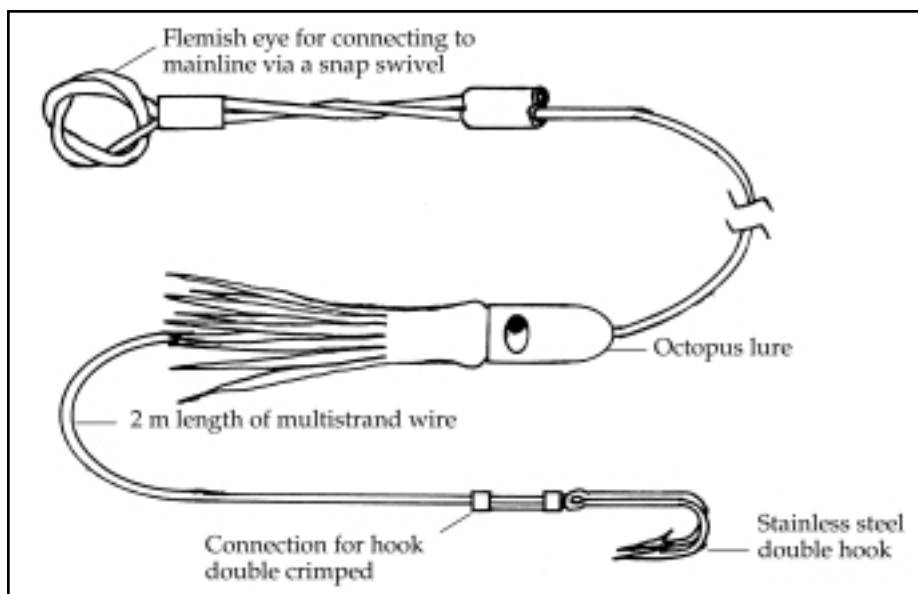

Figure 5: An assembled multistrand wire trolling trace

3.2.2 Fishing operations

Trolling lines were fastened to FTV *Leilani*, two short 30 m trolling lines tied to the transom and two 50 m trolling lines tied to each trolling boom.

Trolling operations were either conducted around two FADs deployed offshore from Kavieng Harbour or in the open-water. One FAD was deployed approximately 4 nm northeast of north Kavieng point and the other was deployed 12.5 nm north of the same point of land. The FAD further offshore was deployed by the Masterfisherman in September 1998. During the course, trolling operations were conducted early in the morning near daybreak or when travelling from one fishing area to another during bottom fishing or tuna longline operations.

3.2.3 Catch and effort

Trolling catches were sporadic during the first training period, with most of the fishing effort conducted offshore between the west coast of New Ireland and Dyaul Island (refer Figure 4). Often a number of large schools of mixed tuna were located 1–5 nm offshore. Few schools of tuna were sited on the east coast from June to September. The FAD deployed 4 nm offshore did not aggregate fish while the FAD deployed further offshore on the east coast in September was moderately effective during the second training period. The students had two good catches in five trips to the FAD. Few schools of tuna were sited on both the east and west coasts during the second period from October to January. The hot, calm weather during the second period possibly affected the feeding patterns of the tuna during that time. Catch and effort results during the two fishing operation periods are outlined in Table 6 with detailed catch data provided in Appendix C (1).

Table 6: Results from trolling operations

Training period	Number of trips	Number of lines	Estimated hours fished	Catch (kg)
17/06–09/07/98	6	6	12	214
21/10–04/11/98	5	6	10	250
Total	11	6	22	464

3.3 VERTICAL DROPLINE

3.3.1 Fabrication of gear

Vertical droplines fabricated during the course were designed to catch bottom fish and should not be confused with vertical longlines fabricated to catch tunas and other pelagic species.

A vertical dropline consists of a flagpole with a buoy attached to support the line vertically in the water, a spool or box to hold or store the line, a mainline, a terminal rig, and a sinker. The mainline was fabricated from tarred 6.4 mm kuralon rope or supertoto line size No. 80. Each mainline was at least 300 m in length so that the dropline could be fished in various depths to target different bottom fish species. The tarred kuralon droplines were stored in wooden boxes while the supertoto lines were wound onto spools. A leaded barrel swivel was tied to the end of the mainline to attach the terminal rig. The terminal rig consisted of six, 2 m lengths of 100 kg test monofilament line joined together in a line with 3-way swivels. Five snoods, 80 cm long made from 50 kg test monofilament line, were tied one to each of the 3-way swivels. A circle or mutzu hook was tied to the end of each snood (hook size varied according to the fishing depth and targeted species). A 2 kg sinker fabricated from two pieces of 19 mm steel re-bar welded together was tied to the end of the terminal rig (Figure 6).

3.3.2 Fishing operations

Setting the gear was a simple operation; the students baited the five hooks on the terminal rig with pieces of skipjack tuna (*Katsuwonus pelamis*). The baited hooks were then lined up on the transom of the FTV *Leilani* and the sinker was gradually lowered into the water until all five hooks were submerged. The mainline was then let free and allowed to descend to the seabed. Once the sinker reached the bottom the mainline was tied to the float attached to the flagpole. When fishing in water shallower than 300 m, the excess mainline was either coiled and attached to the float (for kuralon) or wound onto a spool and the spool attached to the float (for supertoto line). The float and flagpole with the attached mainline was let free and the fishing vessel moved away to set the next vertical longline.

The vertical droplines were left to soak for about 30 minutes to 1 hour before being hauled. Each line was hauled with the hydraulic trap hauler mounted on the starboard side of FTV *Leilani*. When hauling the gear, the flagpole and float were unfastened from the mainline, and the mainline coiled back into a box or rolled onto a spool. Once the terminal rig was reached it was pulled aboard and the fish unhooked. The vertical dropline was then re-baited and deployed again.

3.3.3 Catch and effort

Fishing operations were conducted on both the east and west coasts of New Ireland. The vertical droplines were deployed in depths ranging from 120–280 m. Catches were poor in areas

Figure 6: An assembled vertical dropline terminal rig for bottom fishing

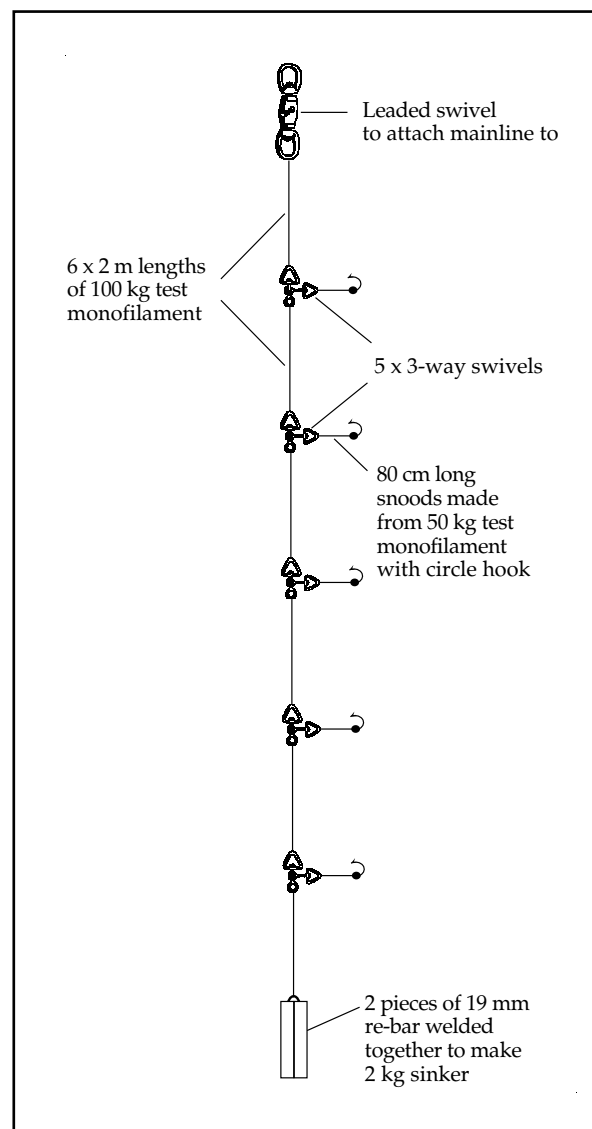

that were exposed to regular fishing pressure near Kavieng. Areas further south on the east coast and on the west coast where fishing pressure is minimal or non-existent were very productive. Catch and effort results from the two fishing operation blocks are outlined in Table 7 with detailed catch data provided in Appendix C (2).

Table 7: Results from vertical dropline operations

Training period	Number of trips	Number of lines set	Estimated hours fished	Catch (kg)
17/06–26/06/98	4	26	11	198
21/10–28/10/98	3	22	10	126
Total	7	48	21	324

3.4 BOTTOM HANDREEL AND HANDLINE

3.4.1 Fabrication of gear

Deep-water fishing operations were carried out using wooden handreels. The handreels (Figure 7) were wound with either 350 m of 150 kg test monofilament line or supertoto line size No. 40. A terminal rig with a swivel at one end and a 1–2 kg sinker at the other was attached to the end of the handreel line. The terminal rig was fabricated using two different configurations. The first consisted of three circle hooks mounted on a 2 m length of wire leader, each hook spaced about 60 cm apart. A 1–2 kg steel re-bar sinker was attached to the end (Figure 8). The second consisted of four, 70 cm lengths of 100 kg test monofilament line joined together in a line with 3-way swivels in between. A 20 cm length of 75 kg test monofilament snood with a circle hook was tied to each of the 3-way swivels (Figure 9). A chum bag was used on many occasions, with this attached to the top swivel of the terminal rig.

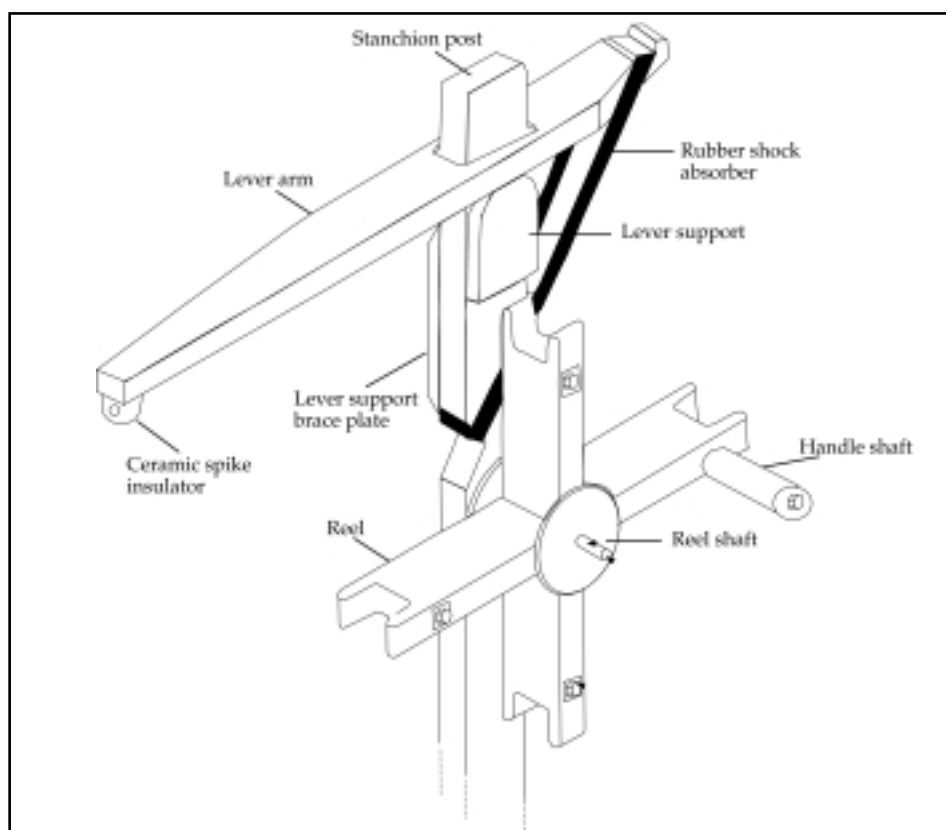

Figure 7: Western Samoan design wooden handreel

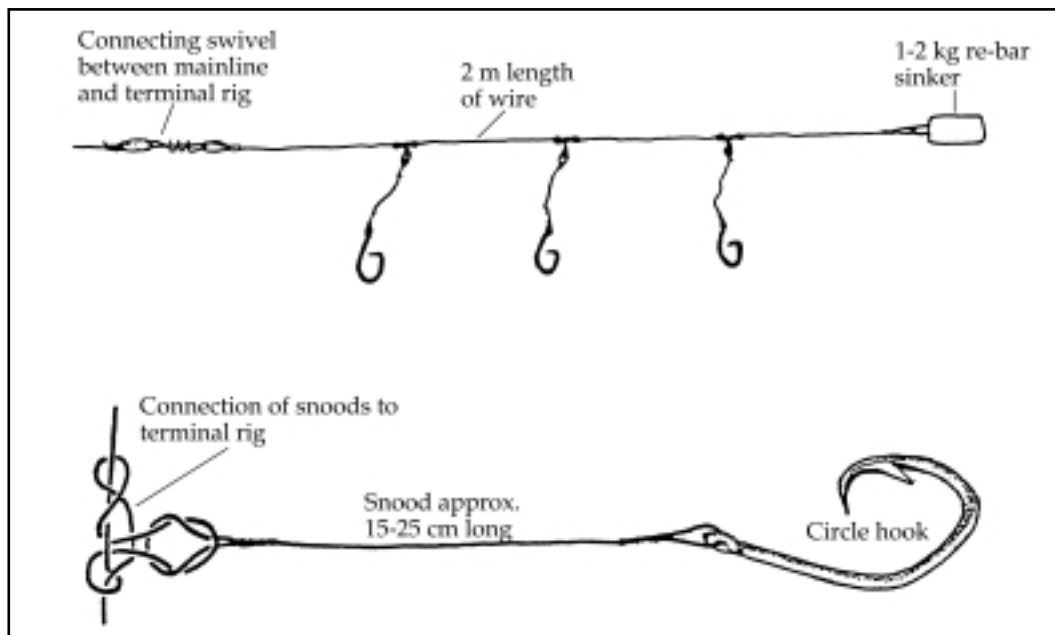

Figure 8: Wire terminal rig arrangement

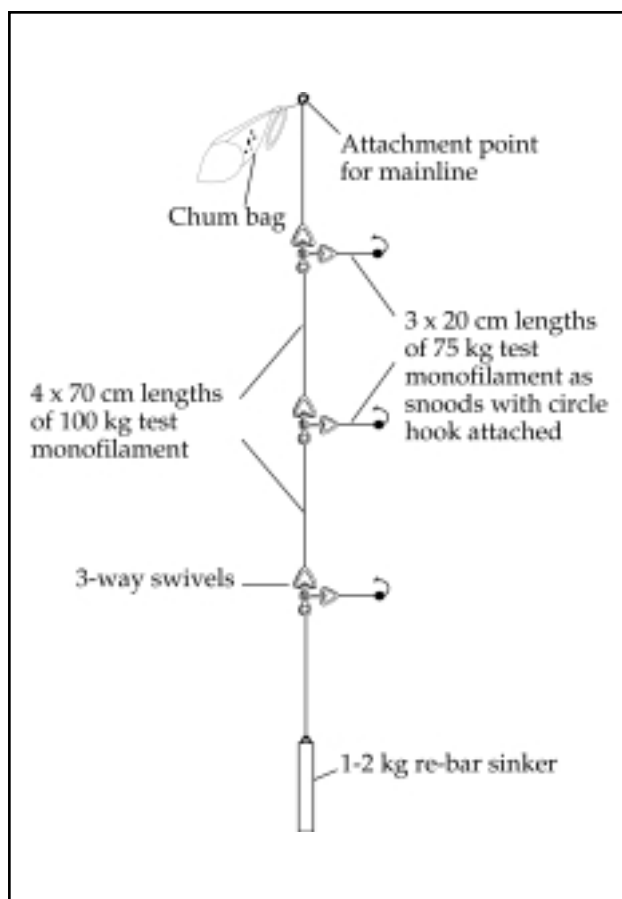

Figure 9: Monofilament terminal rig arrangement

Handlines were used to catch bottom fish in depths from 20–100 m. Each handline consisted of a 100–150 m length of 40–50 kg test monofilament line wound onto a plastic spool. Two circle or ‘J’ hooks were tied approximately 60 cm apart, 30 cm from the end of the handline. A 500 gram lead weight or steel re-bar weight tied to a barrel swivel was fastened to the end of the handline.

3.4.2 Fishing operations

Deep-water handreel fishing operations were conducted in depths from 100–300 m. Once a site was selected the anchor was dropped in shallower water and in a position chosen so that the prevailing wind or current would carry the boat back over the fishing site as the anchor line was paid out. Once the anchor rope was fastened and the boat settled into position facing into the wind and current, the lines from the handreels were lowered into the water until the sinkers reached the seabed. Skipjack tuna was the preferred bait during the fishing operations. If the boat was anchored on a steep reef edge, often the fishing depth would change dramatically as the boat swung with the wind and current.

The students were taught to keep the line taut once the sinker reached the bottom to respond to bites of the fish and to reduce the possibility of the lines tangling. Once the bite was felt the students would pull up the line a few metres to determine whether the fish was hooked or not. If the fish was hooked the line was wound up and the fish landed. Good catches were recorded by this method (Figure 10).

The same procedures were followed for the handline operations, the only difference being that the lines were hauled by hand instead of wound onto a reel. At the completion of fishing activities the anchor was hauled using the hydraulically powered capstan winch.

3.4.3 Catch and effort

Deep-water handreel and handline operations were conducted on both the east and west coasts of New Ireland. The fishing depth for handreel operations ranged from 100–300 m while handline operations ranged from 20–120 m. A wide range of bottom fish species was caught (see Figure 10). Catches were very productive in areas of minimal fishing pressure while areas close to fishing villages or the town of Kavieng were less productive. Poor catches were recorded along the east coast from Utu High School to the southern end of New Hanover Island. Three very productive areas were located on the west coast, one on the northern side of Steffen Strait near the lighthouse, another on the southern end of Selapiu Island and the other on the northern end of Selapiu Island (Figure 4). Catch and effort results for the deep-water handreel operations during the two training blocks are outlined in Table 8, and for handline operations in Table 9. Appendix C (3 & 4) provides more detailed catch data for these two methods.



Figure 10: Students' catch of bottom fish

Table 8: Results from bottom handreel operations

Training period	Number of trips	Number of lines set	Estimated hours fished	Catch (kg)
01/07–09/07/98	2/2days	4	28	521
26/10–04/11/98	3 *	4	26	680
Total	5	4	54	1,201

Table 9: Results from handline operations

Training period	Number of trips	Number of lines set	Estimated hours fished	Catch (kg)
11/08–03/09/98	4	6	24	375
11/11–03/12/98	6	6	26	381
Total	10	6	50	756

3.5 TUNA LONGLINE

3.5.1 Fabrication of gear

The FTV *Leilani* was equipped with a Leahy hydraulically operated reel, which contained approximately 7 nm of 3.2 mm diameter monofilament mainline. With 7 nm of mainline it was possible to set about 200 branchlines spaced approximately 50 m apart. The branchlines fabricated by the students for the longline were very simple. Each branchline consisted of a 14 m length of 2.1 mm clear monofilament line with a swivel snap size 8/0 at one end and a tuna hook with ring at the other (Figure 11). A 2.5 cm length of 2.5 mm inside diameter protective plastic tubing was put over the end of the monofilament line, in the loop end, to prevent chaffing. This was done on both the hook end and the snap end. A bench press was used to crimp aluminium sleeves around the monofilament to hold the loops in place. The branchlines were placed into aluminium boxes with two stainless steel racks attached to the rim. The racks had two rows of stainless steel rod going all the way around for hanging the swivel snaps connected to the branchlines. Two bins were used with each bin holding up to 150 branchlines.

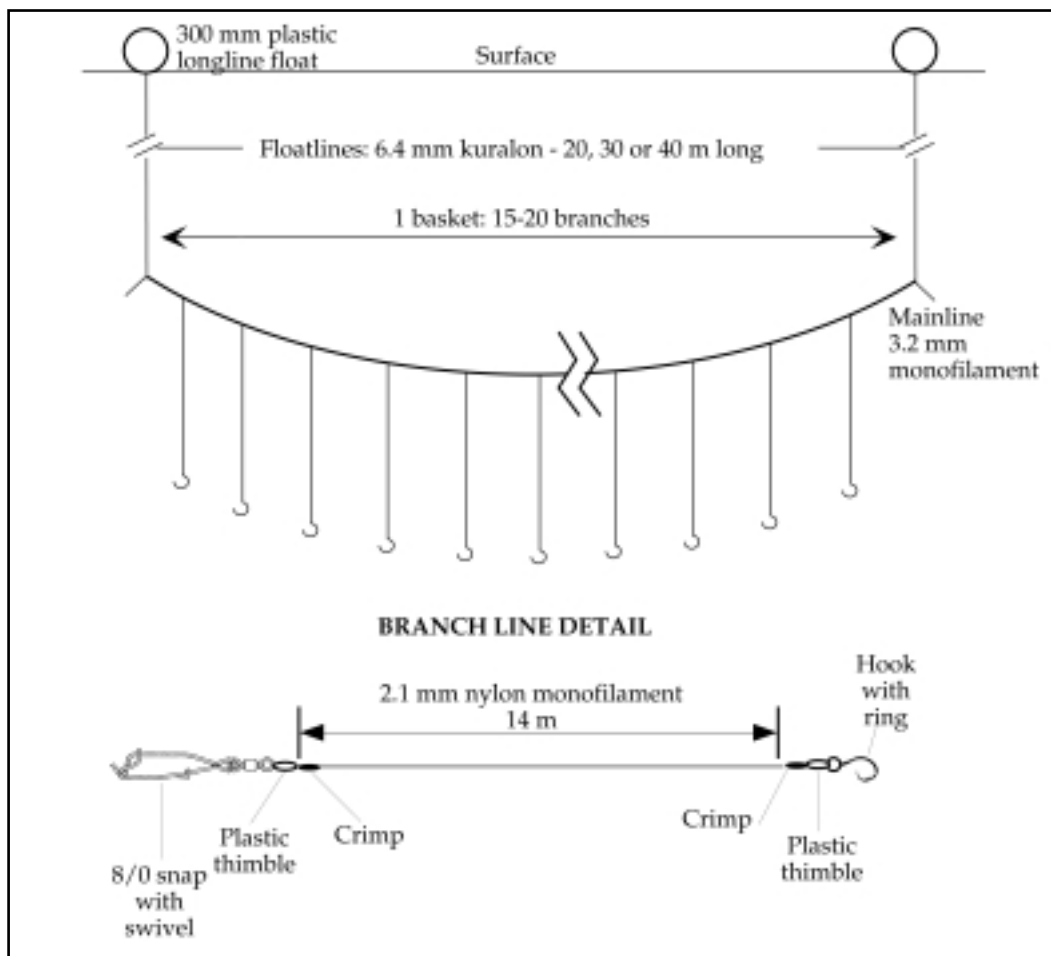

Figure 11: Tuna longline and branchline configuration

The floatlines were fabricated into 20 m, 30 m or 40 m lengths of 6.4 mm tarred kuralon rope. A 9/0 swivel snap was eye-spliced onto one end and an eye-splice 10–15 cm long was formed at the other. The snap end was attached to the mainline and a float was attached to the other. The floats used were 300 mm orange plastic floats, pressure resistant to 300 m. Each float had two ears, on one ear a short piece of tarred kuralon was used to attach a 9/0 swivel snap for clipping onto the floatline. The floats were stored in the stern fish hold and the floatlines were coiled into a wooden box placed near the transom. Radio buoys were placed at either end of the mainline. A tarred kuralon bridle was made for each radio buoy with a heavy duty longline snap to attach it to the mainline.

3.5.2 Fishing operations

Before fishing operations started each day the deck was laid out properly. This included removing the right number of boxes of bait from the ice hold, pulling the mainline through the shooter, and arranging all the floats, floatlines, radio buoys and branchline bins in their proper places. Also a pair of cutters was placed within reach of the baiter so that tangles could be cut before a hook flew back into the boat.

The students were positioned on the deck to perform various tasks during the tuna longline operations. Once the boat was underway in the setting zone at the proper speed and course, a radio buoy was clipped to the mainline and thrown over. As the mainline was thrown from the shooter over the stern, floatlines and branchlines were clipped onto it at appropriate intervals. Aluminium sleeves crimped onto the mainline every 50 m marked where either the floatlines or branchlines were to be attached. Usually 15 branchlines were clipped onto the mainline between floats. To set the gear deeper the long 40 m floatlines were used and 20 branchlines were clipped between the floats (Figure 11).

The mainline was shot off the port side of the stern and baited hooks and floatlines were thrown off the starboard side. The branchline bins were positioned between two students at the stern. One student, the baiter, removed the hook from its snap, baited it and then threw the baited hook overboard. The other student, the snapper, then snapped the clip onto the mainline. A third student removed the coiled branchline from the box to avoid tangles. The branchlines were thrown in the water to lie perpendicular to the mainline to avoid tangles. As the mainline was shot over the stern a fourth student watched for the branchline marks positioned every 50 m along the mainline. When a mark approached the shooter the student yelled out to warn the snapper to clip on a branchline. A fifth student attached the float to the floatline and passed the snap to the snapper to clip onto the mainline after 15–20 branchlines were deployed. The students rotated duties to learn the various skills required to set the longline.

The deck was rearranged for hauling the longline back into the boat; the longline reel was rotated so that it was facing the starboard side of the boat and the branchline boxes were positioned near the wheelhouse by the starboard gunwale.

After the longline soaked for 4 hours it was hauled aboard the boat. The last radio buoy attached to the mainline was pulled aboard first and the end of the mainline passed through the line guide fastened to the starboard gunwale, then secured to the reel. One of the crew operated the control valve for the reel to regulate the speed at which the line was recovered. A student was positioned next to the line guide to unsnap the branchlines and floatlines as they were recovered. The skipper controlled the forward motion of the boat to ensure that the boat did not run-over the mainline. Another student coiled the branchlines back into the branchline bin.

Positioned near the starboard stern, a third student pulled in the floatlines, coiled and stowed them in the wooden box and unsnapped the floats. The remainder of the students were on stand-by waiting to attend to fish when they came to the side of the boat. When a fish was encountered, the skipper stopped the boat and turned to the port side so the mainline would



not go under the boat. The reel was also stopped and the students pulled the fish in by hand. The snap was not removed from the mainline until the fish was gaffed and landed (Figure 12).

Figure 12: Students landing a yellowfin tuna

After the fish was safely on deck, hauling resumed. After all the branchlines were retrieved and the last radio buoy was hauled in, the end of the mainline was secured to the reel. The branchline bins were then secured and the other gear stowed away for the next set.

When hauling, if a large tuna was caught, care was taken to only gaff the fish in the head to ensure the flesh in the body was not damaged. The fish, once on board, was stunned by a firm blow to the head with a heavy club. The club was also used to remove the hook from the fish's mouth. Next, the fish was spiked in the head with a student straddling the fish with one foot on either side behind the pectoral fins, with the fish laying on its belly. The spike was inserted in the soft spot between the eyes and pushed back at a 45 degree angle into the skull. The brain was then destroyed by stirring the spike around.

The fish was then bled by making short, perpendicular cuts on either side of the fish in the pectoral fin recess. Cuts were also made in the gill membrane on one side of the fish, and a sea-water hose inserted. After the bleeding had stopped, the gills and guts were removed. This was done by making a 10 cm incision from the anal opening towards the head along the belly. The gill membranes were cut loose from the pectoral girdle and the gills were cut loose from the head. After the gills were freed, they were pulled through the gill opening with all the guts attached. All the loose tissue was cut away from the inside of the gill cavity and all the membranes cut away from the gill collar. Then the inside of the cavity was scrubbed with a stiff brush and flushed with plenty of water. Lastly, the fish was rinsed to remove blood and debris then placed in the fish hold and thoroughly covered in ice.

3.5.3 Catch and effort

Tuna longline operations were conducted offshore from the east and west coasts of New Ireland, the eastern coast of Dyaul Island and the northeast and northwest coasts of New Hanover Island (refer Figure 4). During the first training period, most of the longline operations were focused offshore from the northeastern coast of Dyaul Island. Catches were consistently good in this area; there was no reason to explore other fishing areas. The catch rate in this area was three times that of the average catch rate (roughly 50 kg/100 hooks) for the Pacific region (Anon., 1988), with the average catch rate for all current tuna longlining activities being over twice the Pacific average at 117.7 kg/100 hooks. This catch rate was almost the same as that achieved during a tuna longline project conducted in East New Britain in 1993/94 which yielded an overall catch rate of 119 kg/100 hooks (Beverly & Chapman, 1996).

By the time longline operations were initiated for the second group of students, the tuna had moved away from this area. Efforts to locate tuna in other areas proved relatively unsuccessful. Only the last set, deployed five miles offshore from the northern tip of Dyaul Island, caught a reasonable number of large yellowfin. The majority of the catch during tuna longlining was yellowfin tuna, with only a few incidental catches of other species. Catch and effort results for the longline operations during the two training periods are outlined in Table 10 with more detailed catch records presented in Appendix C (5).

Table 10: Results from tuna longline operations

Training period	Number of trips	Number of sets	Number of hooks/set	Catch (kg)
15/07–22/08/98	5	9	200	2,745 YF 225 other
11/11–04/12/98	4	7	200	531 YF 264 other
Total	9	16	200	3,276 YF 489 other

*YF—yellowfin tuna other—species for sale or eating locally

3.6 NET FISHING

3.6.1 Fabrication of gear

Three different types of nets were used during the training operations; gillnet, beach-seine and prawn trawl. Training tutorials in technical skills for the fabrication and repair of the nets were conducted by Mr Satoshi Nagashima, JOVC, and Mr Camillus Kabinawedi, NFC staff.

Bottom gillnets (Figure 13) were fabricated by the students from both training periods. Bundles of net mesh were used as there was not enough time to sew all the nets required for the fishing operations. The students were instructed in the method to hang nets on a floatline and attach a footrope. As the nets were negatively buoyant, small floats were fastened 1 m apart along the floatline. The net mesh was then fastened to the floatline with twine tied on either side of the floats. The footrope or leadline was fabricated by fastening small sinkers spaced 1 m apart along the rope. The net was then fastened to the footrope with twine tied every four meshes apart along the rope. The students attached a haul-in line at either end of the floatline.

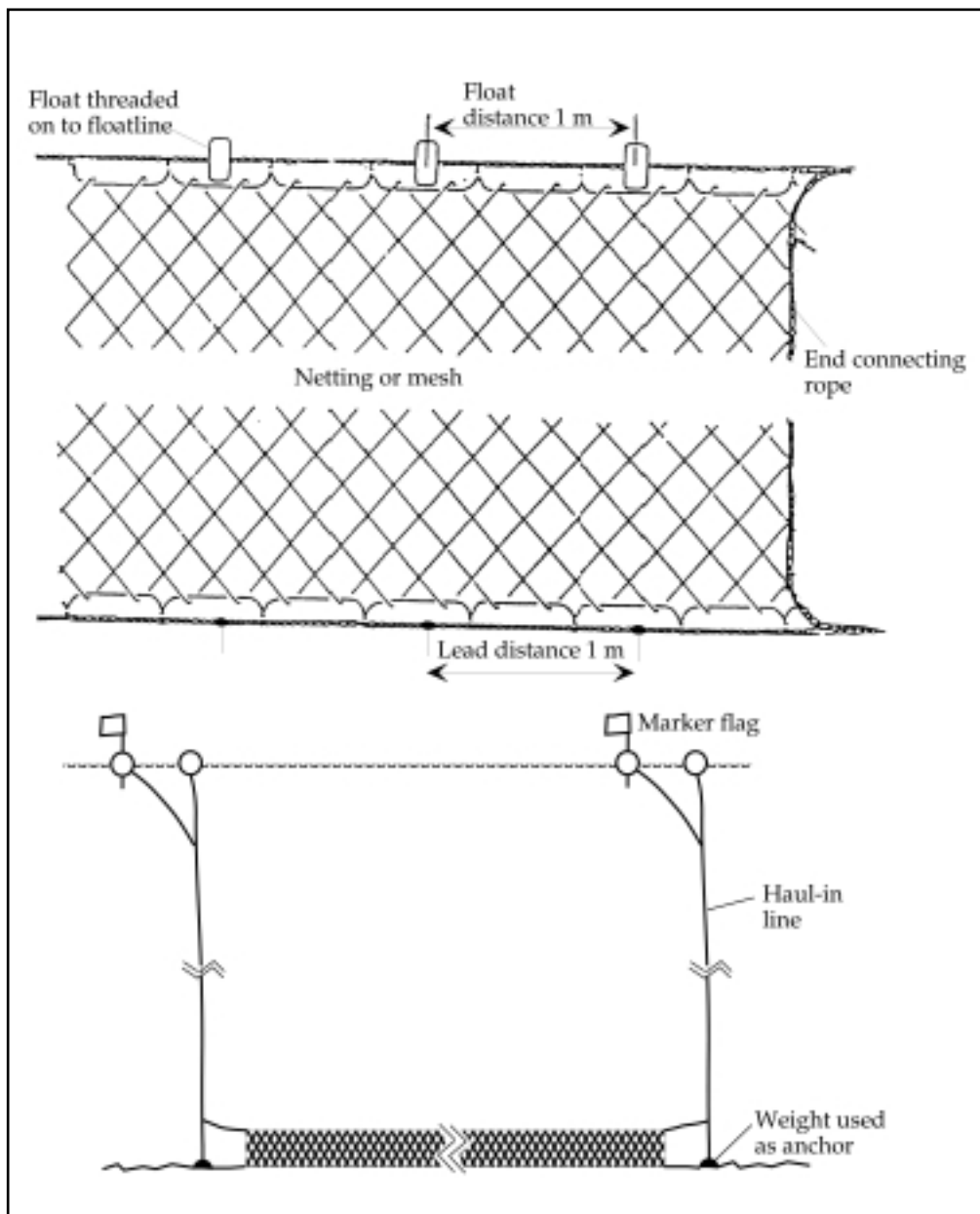

Figure 13: Bottom gillnet

The beach-seine (Figure 14) consisted of two long wings and a section in the middle, called a codend, to retain the fish. The floatline and footrope were similar to that of the gillnets. As the beach-seine was quite long, about 500 m, two short 30 m sections of pre-fabricated netting were sewn by the students to either end of the beach-seine wings. The method for hanging the short wing sections was the same as for the gillnets. When using the beach-seine, long lengths of rope are added to each wing-end to increase the area that can be worked.

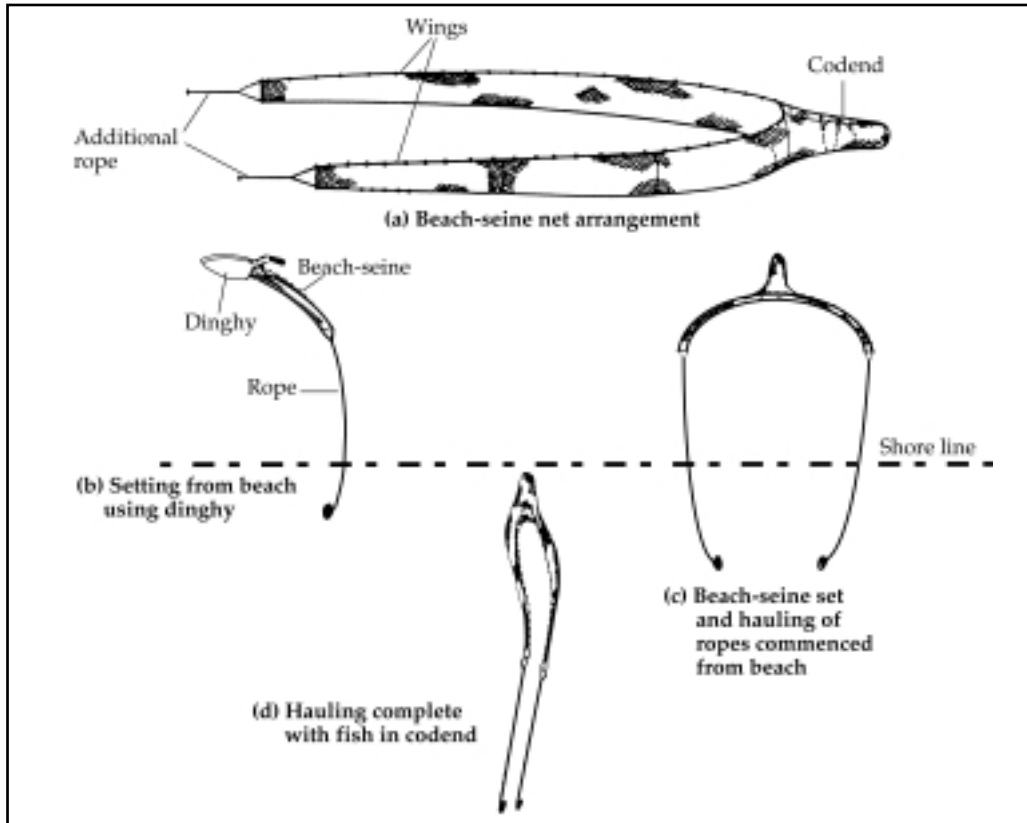

Figure 14: Beach-seine showing setting and hauling process

Bottom trawl nets for catching prawns (Figure 15) were fabricated by the students as this is an important commercial fishery in PNG. The FTV *Leilani* is only 17 m in length and too small to set and retrieve the commercial-sized prawn trawl net normally used in PNG. A reduced, 20 m version of a commercial prawn trawl net used in PNG was fabricated in the first training period. In the second training period, the students made models of the prawn trawl nets as NFC still had four new nets left over from previous courses.

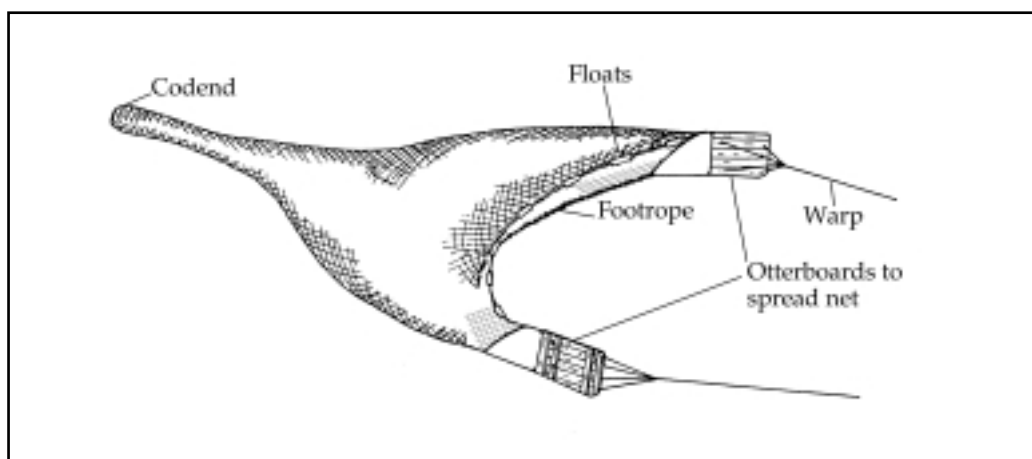

Figure 15: Prawn trawl

The students also received extensive training in the repair of nets. This was of particular importance as two of the main commercial fisheries in PNG are purse-seine and prawn trawl fishing. Deckhands in both of these operations spend a considerable amount of time mending nets.

3.6.2 *Fishing operations*

Mr Nagashima and Mr Kabinawedi were responsible for the net fishing operations. The Masterfisherman only provided assistance when required.

Four to eight gillnets were set during the fishing operations. The nets were faked out across the stern deck of the boat and the ends of each net were tied to one another. At either end of the 4 to 8 nets, haul-in lines were fastened to the floatline. Flagpoles with radar reflectors were tied to the haul-in line at either end. Also, anchors made from stones wrapped in net mesh were tied to either end of the footrope.

The skipper then searched for a proper setting zone, an area with a flat bottom between 15–20 m in depth. After the boat was underway in the setting zone on the desired course, the first anchor and flagpole were lowered into the water. The boat slowly moved forward and the net was gradually paid out over the stern. Once all the nets were deployed the last anchor and flagpole were deployed.

After the nets soaked for 4–6 hours the boat returned to the last flagpole. Once it was retrieved, the haul-in line was retrieved by bringing the end of the first net with anchor to the surface. The net was then hauled by hand at mid-ships over the port gunwale. As the nets were pulled aboard the students removed any fish, pieces of coral and other debris caught in the meshes. Care was taken, as stingrays, stonefish or other poisonous fish were sometimes caught in the net. Once the last flagpole was retrieved, the deck was washed and the debris that was removed from the net was thrown overboard.

The beach-seine was set using a small dinghy and outboard to motor the net in a semi-circle from one point on a beach to another. Before setting, the seabed near the beach was surveyed by a diver with a mask to ensure there were no small coral heads, submerged logs, or other objects which might foul the net when hauled.

The students were divided into two groups, one group onshore and the other on the dinghy to deploy the beach-seine. The rope at the end of one wing was passed to the students on the beach. The dinghy then motored offshore slowly as the rope, and then the net, was paid out (Figure 14). The net was set in a large semi-circle ending at a point further along the beach.

Hauling was accomplished by manually pulling in both ropes equally at the same time, followed by the wings of the net until the codend of the net came ashore with the fish in it. Care was taken to ensure the leadline remained on the bottom and the floatline remained on the surface while hauling to stop fish from escaping.

Prawn trawl fishing is regarded as an active fishing method as the gear is towed. This particular type of trawl was designed to be towed along the seabed. For this fishing operation, the gear was set in an area with a sandy bottom so that the net would not get caught on coral-heads or other objects. Otterboards were used to keep the net open when being towed by the boat.

The prawn trawl was set off the stern of the boat. First, the otterboards were swung over the side of the boat and attached to the winch cables. The net was then unrolled from the net drum over the stern (Figure 16). Once the net was in the water the otterboards were attached to the net. The otterboards were then lowered into the water by unwinding the cables slowly from the winches as the boat moved forward. When the otterboards reached the bottom the boat began towing the prawn trawl net along the seabed.



Figure 16: Setting the prawn trawl

Hauling the prawn trawl was a simple operation. The two winches simultaneously pulled in the cables until the otterboards came to the surface. The otterboards were then disconnected from the net and the net was attached to the net drum. The net was then rolled onto the drum.

3.6.3 Catch and effort

The gillnets were set on a sandy bottom near Ral Island which is leased by NFC. This area was not suitable for catching fish in gillnets as fish tend to feed on the coral reefs near the islands and not on the barren seabed. One set was made in one of the many channels feeding into Byron Strait. The currents in this channel were very strong and the floats, which hold the net vertically in the water, were forced to the bottom. When the nets were hauled, only 2 of the 8 nets were retrieved as the remaining nets were caught on the seabed.

It would have been more suitable to set the nets in areas outside mangroves in sheltered lagoons with a mud bottom. This is the habitat for many fish species, which are susceptible to gillnet capture. Also, there is a minimal possibility of the nets fouling on the bottom. These areas are controlled by traditional land owners who reside on the islands near the fishing grounds. If gillnet fishing operations were conducted in these areas NFC would require permission from the landowners and would need to negotiate a fair distribution of the catch.

Beach-seine operations were conducted on Nago Island. The beach on the southwestern end of the island was suitable for setting and hauling the net as there were no obstructions in the water. Catches were reasonably good for the first set of each training period. Subsequent sets were less productive.

Prawns are not found in waters within a reasonable distance of Kavieng. In PNG prawns are typically caught near large river mouths which flow into the ocean. The prawn trawl was set and hauled only to demonstrate the technique to the students. Catch and effort for the net fishing operations during two training periods are outlined in Table 11 with detailed catch records found in Appendix C (6, 7 & 8).

Table 11: Results from the net operations

Fishing method	Training period	Number of sets	Catch (kg)
Gillnet	12/08–20/08/98	4	5
	09/12–16/12/98	4	nil
Beach-seine	26/08–03/09/98	9	110
	24/12–31/12/98	4	50
Prawn trawl	26/08-03/09/98	4	nil
	24/12-31/12/98	3	nil

3.7 FISH PROCESSING

The FTV *Leilani* was scheduled to return to Kavieng on Thursday afternoons to enable the students who remained onshore to be trained in various fish processing methods. Once in port the catch was off-loaded from the boat and transported directly to the fish processing plant on the NFC campus.

At the processing plant the fish were weighed and laid out on stainless steel cutting tables (Figure 17). The students were then trained to gut and clean the fish properly by the seafood technologist. Practical demonstrations were given in the techniques of filleting and loining fish. The students had the opportunity to practise their skills in processing fish throughout the course. By the end of each training period they were quite proficient. The filleted or loined fish were wrapped in clear plastic and placed in trays. The trays were stacked one on top of each other in such a way that there was an air space in between and then placed into the freezers.



Figure 17: Students processing fish

The students were also taught methods of smoking and salting fish for preservation. Smoking the fish consisted of filleting the fish then hanging the fish on racks. The racks were placed in a smoke oven and the fish were smoked for a few hours. To salt fish the students filleted the fish then soaked them in a saltwater brine for 8 hours. The fillets were then hung on racks to dry.

3.8 DATA COLLECTION

Detailed records for each fishing trip were made by the Masterfisherman. A form for collecting data was designed for trolling, vertical dropline, bottom handreel and handline operations. Data collected for each trip included fishing area, time out and time in, number of hours fished, number of hooks used, weather conditions, total number and weight of each species caught, and general comments concerning the fishing trip. A separate data collection form was designed for tuna longline operations. Data collected for each tuna longline trip included fishing area, number of hooks used, setting start position, setting finish position, hauling start position, hauling finish position, setting time, hauling time, weather conditions, weight of each species caught and general comments. The two data collection forms are shown in Appendix D.

Fish caught during the training courses were filleted or loined. They were then sent to the NFC kitchen to feed the students, distributed to the staff or sold to restaurants and grocery stores in Kavieng. Total sales of fish were K 5,400. Also over K 900 was donated to the Aitape Disaster Relief Fund from fish sold at the College.

4. CATCH AND EFFORT SUMMARY

Fishing operations for the Fishing Cadet Course at the NFC were split into two training periods; the first commencing on 15 June and continuing to 28 August 1998, and the second commencing on 21 October and continuing to 31 December 1998. Fishing operations included trolling, vertical dropline, deep-water handreel, handline, tuna longline, gillnet, beach-seine, and prawn trawl fishing methods. A total of 28 trips were undertaken, (17 two-day trips and 9 one-day trips). Total catch for all the fishing operations was 6,675 kg. All weights of bottom fish given in the report are whole-fish weights whilst tuna weights are of gilled and gutted fish. A summary of the catch and effort for all the fishing operations during the two training blocks is given in Table 12.

Table 12: Summary of catch and effort for fishing operations

Fishing method	Number of sets	Number of hooks	Estimated hours fished	Catch (kg)
Trolling	NA	6	22	464
Vertical dropline	48	5 per set	21	324
Handreel	NA	3 x 4	54	1,201
Handline	NA	2 x 6	50	756
Tuna longline	16	200 per set	NA	3,276 YF 489 other
Gillnet	5	NA	NA	5
Beach-seine	13	NA	NA	160
Prawn trawl	7	NA	NA	–
Total catch				6,675

5. SPECIES COMPOSITION OF THE CATCH

The main aim of the second module of the Fisheries Cadet Course, held at NFC, is to have the students gain hands-on experience in fishing methods and fish handling and processing techniques, so they can gain employment on commercial fishing vessels in PNG. Therefore, identification of all individual fish species was not necessary, but rather, data was collected more in relation to the commercially important groups of species, and in some cases the species within these groups, for the main fishing method.

The total catch recorded for vertical dropline and bottom handreel fishing combined was 700 fish with a whole weight of 1,525 kg. Of this, the high-value deep-water snappers made up 80 per cent of the catch by weight (1,220 kg), which is a very high percentage of the total catch by these methods. The next most important species groups were the jacks and trevallies (118 kg—7.7%) and groupers, cods and coral trouts (109 kg—7.1%). Appendix E provides a more detailed breakdown of the species caught by these methods.

Tuna longlining provided the highest yield, with 150 fish weighing 3,765 kg. Of this catch, yellowfin tuna (*Thunnus albacares*) was the most predominant species, making up 74.7 per cent of the catch by number (112 fish) and 87 per cent of the catch by weight (3,276 kg). Mahi mahi (*Coryphaena hippurus*) and sailfish (*Istiophorus platypterus*) were the next most common species in the catch. Appendix F details the species caught by this method.

From the other methods used, only catches from trolling were recorded by species. For trolling, skipjack tuna (*Katsuwonus pelamis*) was the most common species followed by juvenile yellowfin tuna. The species composition for trolling is presented in Appendix F. For all other methods, only basic information was recorded without a breakdown on the species composition.

6. OTHER ACTIVITIES

6.1 FAD DEPLOYMENT

6.1.1 Introduction

A component of the fishing operations for the Fishing Cadet Course at NFC was trolling for pelagic species. Trolling is not only an important fishing method for the students to learn but it also provides bait for other fishing operations. Trolling activities are conducted in the open water or around FADs. Fishing around FADs is usually more productive than in the open water as FADs, when properly positioned, will aggregate schools of tunas and other pelagic species and hold them for up to 3–4 weeks. Also, FADs provide the opportunity for using a number of effective fishing methods for capturing large pelagic fish. These fishing methods include vertical longline, 'drop stone', 'ika shibi', and 'palu ahi'.

A FAD was deployed off Kavieng by the Fisheries Research Division in 1996. It was originally stationed 6 nm northwest of Kavieng Harbour. After a few months on site, the FAD drifted inshore and finally settled 3 nm offshore in 350 m of water. During the first training period of the Masterfisherman's assignment, the FAD was visited five times and only one mahi mahi was caught. The Masterfisherman concluded the FAD was positioned too close to shore to properly aggregate pelagic species.

As the FAD deployed by the Fisheries Research Division was not aggregating fish, it was decided that another FAD should be deployed further offshore in the hope that it would be more effective. The Capture Section of SPC provided the funding for the purchase of FAD materials. The Masterfisherman, also a FAD specialist, supervised the FAD site surveys, procurement of materials, fabrication and deployment of the FAD.

6.1.2 FAD site survey

FAD site surveys began in early September after consultations with the NFC staff and local fishermen to determine areas within a reasonable distance from Kavieng where schools of tuna are generally found. Two criteria were used to determine the survey area: distance offshore (5–10 nm) and depth (1,000 m plus). The area selected for the FAD site survey was Latitude 02° 20.00' S to 02° 21.00' S by Longitude 150° 48.00' E to 150° 50.00' E. This area according to the charts was approximately 12 nm offshore and the average depth within the survey zone was 1,000 m.

The FTV *Leilani* was used for the site survey and later for the deployment of the FAD. It was ideally equipped for the job with a JRC colour echo-sounder with a 28 kHz transducer capable of recording depths to 3,000 m, a JRC colour plotter with GPS and an auto-pilot.

The method used for the FAD site survey consisted of following transects in a north–south direction. Each transect within the survey zone was spaced 0.25 nm apart. Along each transect at intervals of 0.25 nm the depth was recorded from the sounder. Thus, the depth data was recorded at 0.25 nm² intervals throughout the 1 nm by 2 nm survey zone.

The vessel followed each transect within the zone by using the GPS, plotter and auto-pilot. If for example, the vessel was following a transect line starting from Latitude 02° 20.00' S by Longitude 150° 48.00' E and was going to Latitude 02° 21.00' S by Longitude 150° 48.00' E, the skipper would position the cursor of the plotter over the position Latitude 02° 21.00' S by Longitude 150° 48.00' E and enter it as a waypoint. The plotter would then calculate the course for the vessel to follow to the waypoint. The course was then set on the auto-pilot and it would steer the vessel along the transect line to the waypoint. The same procedure was followed to travel 0.25 nm from one transect to another.

All the depths and positions recorded in the survey zone were transposed to a sheet of graph paper. The contour lines were then drawn by selecting and connecting points of similar depth at 100 m intervals. Since most of the depths recorded were something other than a multiple of 100, the position of the 100 m interval was deduced by interpolation. When all the contour lines were drawn on the graph paper, the bottom topography of the survey zone was shown (Figure 18). From this information the most suitable FAD site was selected. The selected position of the FAD site within the survey zone was Latitude 02° 20.50' S by Longitude 150° 48.50' E, with a depth of 1,000 m.

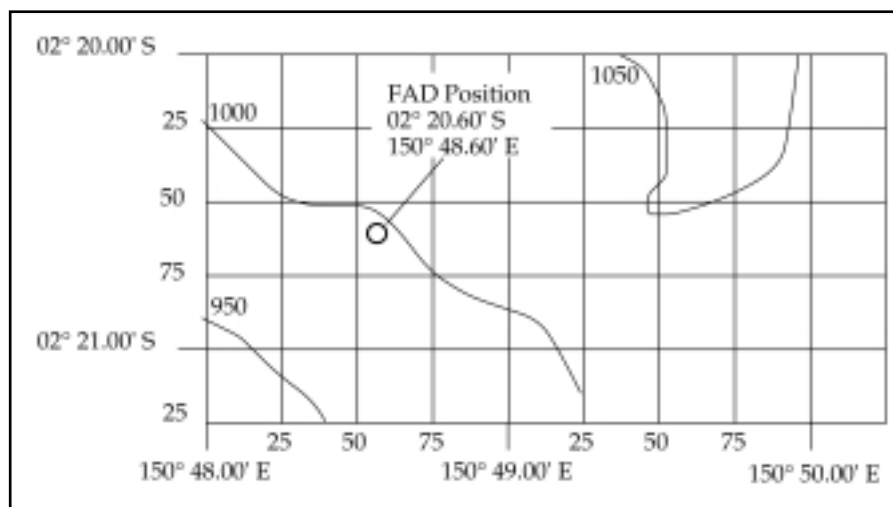

Figure 18: FAD contour map

6.1.3 FAD assembly and rigging

Buoy

The design of the FAD buoy and mooring were based on the Indian Ocean design recommended in the SPC manual Rigging Deep-Water Moorings (Gates et al., 1996). The design was modified and a number of components changed to reduce costs. Most of the materials for the buoy were salvaged from equipment used in previous fishing operations at NFC.

The buoy was fabricated by stringing 40 hard plastic longline floats on a 30 m length of 14 mm galvanised steel cable (Figure 19). The plastic longline floats were 200 mm in diameter and were pressure resistant to 300 m. Each float had two ears with 16 mm holes for attaching ropes. A 20 m length of flexible plastic hose with a diameter of 16 mm was pulled over the galvanised steel cable. The cable covered with the plastic hose was then pulled through one of the ears of each plastic longline float. The plastic hose acted to reduce abrasion between the cable and the ear of the longline float. Grease was rubbed into the exposed sections of the galvanised cable. The longline floats were spaced 25 cm apart along the cable to eliminate the possibility of the floats rubbing against one another. The floats were lashed to the cable with tarred kuralon rope to hold them in place.



Figure 19: FAD buoy arrangement

An eye splice with a 16 mm galvanised thimble was formed at either end of the cable to attach the upper mooring rope and a bridle for a large 1.5 m by 1 m tubular hard plastic float. The nylon rope in the upper mooring was attached to an eye at the end of the cable with two 16 mm galvanised shackles with a 16 mm galvanised swivel in between. The bridle for the large float consisted of two, 3 m lengths of 16 mm 3-strand nylon rope spliced to two attachment points on one end of the float. The bridle was fastened to the buoy cable with a 16 mm shackle. Another bridle was spliced to two attachment points on the other end of the large float. This bridle was attached to a flagpole with a 16 mm shackle. The flagpole was fabricated using a 4 m length of 19 mm diameter galvanised pipe with three purse-seine floats for buoyancy. A 3 m length of 25 mm steel re-bar was welded to the bottom of the galvanised pipe to act as a counterweight. A fibreglass pole-and-line fishing pole was bolted to the upper section of the galvanised pipe to attach a flag.

Aggregators

Two-metre lengths of plastic strapping and frayed nylon rope were lashed to the 10 m length of exposed galvanised buoy cable. The aggregators were lashed closely together along the cable starting 1.5 m from the last longline float and ending 5 m from the eye splice attachment for the upper mooring.

Mooring ropes

A catenary curve mooring system was fabricated for the FAD. This mooring system uses a combination of sinking nylon rope for the upper section and buoyant polypropylene rope for the lower section of the mooring to form a curve in the water where the ropes are joined. The curve builds excess rope into the mooring and stores it safely below the surface. The excess rope absorbs much of the energy produced by the buoy on the mooring in rough seas and thus protects the mooring. The ropes for the mooring were 16 mm diameter 3-strand nylon rope and 17 mm 3-strand polypropylene rope.

To calculate the rope lengths for the catenary curve mooring system for this FAD the SPC "Work Sheets for Catenary Curve Mooring Rope and Buoyancy Calculations" (Petaia & Chapman, 1997) was used.

The calculation process was carried out using the following information:

- FAD site depth was 1,000 m
- weight of the polypropylene rope being used was 5 kg/30 m
- the length of rope for making up the catenary course is 25 per cent of the site depth;
- 75 per cent of the catenary curve is polypropylene rope (positively buoyant);
- the top of the catenary curve is held 150 m below the surface;
- 3 m of bottom hardware needs to be lifted off the seabed through buoyancy to protect the rope from chaffing;
- weight of the 3 m of lower mooring hardware being used was 18 kg
- the weight of steel in seawater is 86.9 per cent of its weight in air; and
- one metre of polypropylene rope in seawater can buoy up 11.6 per cent of its weight in air.

The rope lengths for the FAD site in a depth of 1,000 m were 320 m of nylon rope and 900 m of polypropylene rope.

Once the rope lengths were determined, the nylon and polypropylene ropes were faked out and cut to length. When faking out the ropes all the kinks were unravelled to ensure the ropes would not hockle when the FAD was deployed. The nylon and polypropylene ropes were spliced together and eyes were spliced into each end of the mooring rope to fit 16 mm galvanised steel thimbles. The polypropylene rope was faked out first on the deck followed by the nylon rope as the upper mooring would be deployed first. Once the ropes were faked out on the deck, shackles were fastened into the eyes at either end. The eye at the nylon end of the mooring rope was fastened to the eye of the galvanised steel cable of the buoy with two 16 mm galvanised shackles and a 16 mm galvanised swivel in between. The eye at the polypropylene end of the mooring rope was fastened to a 15 m length of 19 mm galvanised chain with two 19 mm galvanised shackles and a 19 mm galvanised swivel in between.

Anchor

The FAD anchor was a 1.5 t bulldozer track. The track was coiled up and pieces of steel re-bar were welded across the top to keep the track from unravelling (Figure 20). An anchor platform was fabricated on the starboard side of the stern deck. The platform consisted of 5 wooden pallets stacked one on top of the other. On top of the platform two, 4 m lengths of 10 cm x 10 cm hardwood timbers were placed to span both gunwales. A 1.3 m x 1.3 m piece of 19 mm plywood was then placed on top of the two timbers over the platform. The bulldozer track was later laid horizontally on the piece of plywood with a crane. When the FAD was ready for deployment the lower mooring chain assembly was fastened to the track with a 19 mm shackle.



Figure 20: Bulldozer track on platform ready for FAD deployment

6.1.4 FAD deployment procedures

The position of the FAD site was recorded in the memory of the GPS. Following the course set by the GPS, the FTV *Leilani* returned to the site and reconfirmed the position and depth. The FAD buoy, mooring and anchor were then prepared for deployment.

The circular deployment technique was used. From the FAD site position the vessel turned up-wind and lowered the buoy into the water. The vessel then slowly motored forward while the mooring rope was paid out over the stern. A circular course was followed until all the rope was paid out. The bottom chain was then lowered into the water and the anchor was tipped overboard by lifting up the two hardwood timbers.

As the anchor descended towards the bottom the crew and students kept watch on the buoy as it moved across the ocean surface. When the anchor reached the bottom and the buoy was finally stationary, the position and depth were recorded. The position of the buoy was Latitude 02° 20.60' S by Longitude 150° 48.60' E in a depth of 1,000 m.

6.1.5 Results

The FAD was visited five times during the second training block. Two good catches were recorded, one of 110 kg and the other of 140 kg. The catches were comprised of mixed juvenile yellowfin tuna and skipjack tuna from 3–5 kg. Unfortunately, the FAD was lost approximately four months after deployment. It was assumed that the FAD was cut loose by 'rascals' wanting to steal the plastic longline floats and galvanised wire cable.

6.2 FISHING GEAR TECHNOLOGY TRAINING MANUAL

A manual to assist tutors in teaching students practical skills to fabricate fishing gears used during fishing operations was designed for the Fishing Cadet Course. Detailed descriptions with illustrations of fabrication methods for the fishing gears included in the course syllabus were outlined in six chapters. Contents of the training manual are detailed in Table 13.

Table 13: Contents of the fishing gear technology training manual

Chapter	Contents
Trolling	Boat arrangement, tools and utensils, hooks, types of trolling lines, preparing trolling lines, assembling trolling lines, rigging shock absorbers, making up octopus lures, landing fish
Vertical dropline	Vertical dropline configuration, terminal rig
Bottom fishing	Bottom reels, self-hauling anchor, anchor-retrieval method, handline
Tuna longline fishing	Types of branchlines, conventional longline, monofilament longline, boat layout, description of tuna longlining
Net fishing	Tools, basic net construction, mending nets, hanging nets, gillnets, beach-seine, trawl nets
Knots and splices	Illustrated methods for tying various knots and splicing ropes and wire
Technical references	Provided for further reading

The students attending the second training period were issued a copy of the manual. It was used for reference purposes during practical fishing technology training sessions.

7. CONCLUSIONS AND RECOMMENDATIONS

7.1 GENERAL CONCLUSIONS

With the expansion of the domestic commercial fishery due to regulations created by the government to encourage local investment in the industry, the Fishing Cadet Course has begun to meet the manpower needs in training deckhands for commercial fishing vessels. Reports from the commercial fishing companies who have either accepted students for the Industrial Attachment or hired graduates from the Fishing Cadet Course indicate that the skill level of the students is of a standard acceptable for the industry.

Every student who graduated from the first training period in 1998 was offered a job in the industry. For the Industrial Attachment of the second period, the demand from the industry was greater than the number of students available.

NFC is ideal for training deckhands in a number of different fishing methodologies. Located near Kavieng there are a number of island reefs and lagoons, which are abundant in pelagic and demersal fish species. These areas provide an opportunity to train the students in a number of fishing techniques; beach-seine, gillnet, handline and troll fishing. The near-shore and offshore resources are relatively unexploited. The outer reef slopes for the most part receive no fishing pressure in depths of more than 100 m and are suitable for deep-water handreel fishing. Only reef slopes within close proximity to Kavieng show signs of over fishing. Offshore the abundant pelagic resources are ideal for training students in troll and tuna longline fishing. Unfortunately, there being no prawns in the area, only demonstrations of the setting and hauling of the trawl net were feasible.

Catches from the fishing operations during the two training periods for the Fishing Cadet Courses were generally quite good. A total of 6,675 kg were caught in 28 fishing trips. Bottom fish caught with vertical droplines, handreels and handlines comprised 2,281 kg of the total. Sixteen tuna longline sets of 200 hooks produced 3,765 kg. Tuna longline catch rates during the first training period were three times higher than the average catch rate for the Pacific region. The combined tuna longline catches for both training blocks were two times higher than the average catch rate for the Pacific region.

As the industry continues to expand, the requirements for skilled manpower will also expand. At present, most of the Fishing Master/captains and engineers employed on the domestic commercial fishing fleets are expatriates. In the future NFC will be required to develop new courses to train PNG nationals in more specialised skills to take full advantage of the career opportunities available in the fishing industry.

7.2 SPECIFIC CONCLUSIONS

The cost to the PNG government for each student who attends the Fishing Cadet Course is very high. The expense of the course could be dramatically reduced if the students were sent directly to NFC in Kavieng instead of spending three months at the Maritime College in Madang. Students only require pre-sea training in first aid, safety at sea and fire fighting to work as deckhands on a commercial vessel. It is not necessary for them to have Deck and Engine Rating 2 certification. The pre-sea induction could be reduced to 2–3 weeks. If this course was transferred to NFC it would save the expense of transporting the students to Madang. Also, there would be considerable savings if the course was reduced from three months to 2–3 weeks.

Tutors at NFC could be certified to conduct the pre-sea induction course to a standard acceptable to the PNG Department of Transport. In the meantime, NFC could hire certified tutors from the Maritime College for a 2–3 week period to conduct the pre-sea training course. If tutors from the Maritime College were not available, tutors with recognised certification in pre-sea training from overseas could be hired on short-term contracts. This would still be less expensive than a three-month course held at the Maritime College in Madang.

The two-week course in Fisheries Legislation and Regulations held at NFC after the Industrial Attachment could be rescheduled to be completed in Kavieng at the end of the Fisheries Technology Training Module. The students could then return home after the Industrial Attachment thereby saving the expense of returning to Kavieng. The students who successfully complete all three modules would have their 'Certificates in Fishing Technology' mailed to them rather than attending a graduation ceremony after completion of the Fisheries Legislation and Regulations course.

The present selection process for students desiring to attend the Fishing Cadet Course is not effective. Even though there have been as many as 2,000 applicants for 20 positions available in the course, there are still students selected who have difficulty in learning basic technical skills, have medical problems or lack motivation. The reason, in part, for the large number of applicants is that the course is entirely paid for by the government. If there were tuition fees for the course, it is likely the number of applicants would be reduced. Also, those who did apply, knowing they would be required to pay in part for the course, would be more committed to making fisheries a full-time career.

If the government continues to finance students attending the Fishing Cadet Course one possible solution for selecting students would be to have a mobile team conduct two-week pre-sea induction courses at various locations throughout PNG. Persons who successfully complete the pre-sea induction course would then qualify to apply for the Fishing Cadet Course. Selection would be based on the performance of the person during the pre-sea induction course.

The present syllabus of the Fishing Cadet Course is more or less a reduced version of the two-year Tropical Fisheries Course previously offered at NFC. Although the Fishing Cadet Course is more oriented towards commercial fishing, the students still receive training in areas which are not relevant to working as a deckhand on a commercial fishing vessel. Students are trained in mechanics, carpentry, refrigeration and on-shore post-harvest skills. Training in these skills should be offered in individual specialised courses either at NFC or the Maritime College.

Training in fishing technology and fishing operations should be the main focus of the course. More time should be spent at sea to learn basic seamanship skills and fishing techniques to work in the main commercial fisheries.

After the Fishing Cadets have worked in the industry for a certain length of time they should qualify to receive more specialised training if they desire. A career path determined by certification in various skills should be developed by NFC with inputs from the Fishing Industry Association. Specialised courses should be offered in boat building, engineering, refrigeration, Masterfisherman, post-harvest operations, and advanced navigation skills.

At present, the tutors at NFC are under utilised; the two Fishing Cadet Courses only occupy six months of the year. Tutors not involved in fishing operations or training in practical fisheries technology skills only teach a few hours a week. If the college provided more specialised courses for the fishing industry, the tutors would not only be more productive but additional revenues could be generated from the other courses.

The tutors at NFC have sufficient training and skills to proficiently conduct the Fishing Cadet Course at its present level. However, if the College intends to incorporate more specialised training courses to fill the manpower requirements of the commercial fishery the tutors will require further training. Expatriate technical expertise will be required until national tutors qualify to teach more specialised courses.

The purse-seine fishery is one of the three main commercial fisheries in PNG. This industry has the potential for employing many PNG nationals. Few nationals are employed in the fishery at present as there is a lack of skilled manpower. NFC does not offer any specific training in purse-seine fishing skills other than net mending. Consideration should be given to purchasing materials to train the students in the fabrication of a small purse-seine net similar to those used by inshore fishermen in the Philippines and Indonesia. With a small purse-seine net it would be possible to conduct fishing operations with the FTV *Leilani* to capture small schools of bonito, skipjack, yellowfin and other pelagic species.

Fishing operations include gillnet and beach-seine fishing. Although, these nets are used by village fishermen throughout PNG, they are used for subsistence and not in the Industrial Fishery which is the focus of the Fishing Cadet Course. If these fishing methods were dropped from the fishing operations programme, or their content greatly reduced, more time could be spent training students in tuna longline and purse-seine fishing techniques.

If the course continues to include gillnet and beach-seine fishing methods, NFC should approach the village fishermen who control the fishing grounds near the islands and lagoons and negotiate the right to conduct fishing exercises. Conducting fishing operations in areas which are not suitable for the fishing gear is a waste of time and effort. It also does not give the students a proper understanding of the use of the fishing gear. Learning 'where and how' to catch fish is as important as learning how to fabricate the fishing gear.

The catches during fishing operations at NFC have been poor. For several years most fishing operations have taken place near Kavieng in areas which are suffering from over exploitation. Searching for productive fishing grounds is one of the main occupations of any commercial fishing operation. To be profitable the crew on a commercial vessel must maximise its fishing effort in the most productive fishing grounds to catch as much fish as possible for the least expense. Many fishing companies pay their crew a percentage of the profits from their catch as an incentive. NFC does not provide any incentives for the crew of FTV *Leilani* to maximise their efforts during fishing operations. The crew receives the same salary whether they have a good catch or not. Therefore, there is little incentive to catch fish. If NFC intends to provide the training to prepare students for employment in the industrial fishery, the fishing operations aboard the training vessel should be managed in a manner similar to a commercial fishing operation. Some incentive scheme should be considered to encourage the crew of FTV *Leilani* to maximise their fishing efforts during fishing operations with the students. Caution may need to be applied to ensure that, over time, depletion of certain resources did not occur in specific areas.

NFC employs only one qualified skipper and engineer to work on the FTV *Leilani*. If one of the two is not able to work on the vessel due to sickness or for some other reason, the vessel cannot legally go to sea. The College should either have qualified persons on stand-by or train some of the present staff to qualify to operate and maintain the vessel while at sea.

The fishing master/skipper and engineer of the FTV *Leilani* should build up a stock of fishing gear and spare mechanical parts for the boat before each training course. There should be a ready supply of bait and ice for fishing operations. Training should not come to a halt due to a lack of essential materials to conduct fishing operations.

The ice machine on FTV *Leilani* has not worked properly since the vessel arrived in Kavieng. It constantly breaks down and has been repaired a number of times without success. The practical fishing operations require a ready supply of ice for the catch and on board fish handling demonstrations. As it occupies precious space on the deck, the ice machine should be removed from the vessel and either sold, or installed onshore in one of the waterfront workshops. If the ice machine is sold, a machine with greater ice-making capacity should be purchased and installed onshore. The ice machine should be purchased from a dealer from whom spare parts are readily available.

Safety of the crew and students while at sea cannot be over emphasised. The FTV *Leilani* is equipped with all the safety equipment required by law for a training vessel. As of January 1999, some of the safety equipment will be out of date and the vessel is required to be surveyed. Updating the safety equipment and surveying the vessel before the next training session should be a priority.

The FTV *Leilani* is equipped with a HF and VHF radio for communications. Even though both of these radios are operational, often the marine frequencies on these radios for emergencies are not regularly monitored in PNG. NFC should purchase a HF radio and set up a base station which is regularly monitored at the college in case of emergency or if important information needs to be transmitted from ship to shore or vice versa.

The national government, Fishing Industry Association and the marine training institutions should work closely together to ensure that the training needs of the expanding commercial fishery are met and that gradually the more skilled positions aboard fishing vessels are filled by PNG nationals.

7.3 RECOMMENDATIONS

In consideration of the present level of the commercial fisheries in PNG, the manpower requirements for the expanding industry, and the results and observations of the Masterfisherman during the work undertaken for the Fishing Cadet Course at NFC, the following recommendations are made.

It is recommended that:

- (a) NFA and NFC closely monitor the training needs of the fishing industry and develop new courses to train PNG nationals in more specialised skills to take full advantage of future career opportunities available within the fishing industry;
- (b) NFA and NFC consider moving the first module of the Fishing Cadet Course to Kavieng and reducing the course content to a 2–3 week pre-sea induction course only, tailored to the fishing industry's needs;
- (c) In line with recommendation (b) above, suitable tutors be used to run the 2–3 week pre-sea induction course in Kavieng while NFC tutors gain the necessary qualifications and certification to teach these courses themselves;
- (d) NFA and NFC look at rescheduling the two-week Fisheries Legislation and Regulations course to follow on from the Fishing Technology course to reduce the overall cost of the course;
- (e) NFA and NFC consider implementing a tuition fee for students selected for the Fisheries Cadet Course as a means of ensuring that applicants are fully motivated;
- (f) NFA and NFC consider a more thorough selection process, possibly through having a mobile team conducting a two-week, pre-sea induction course at various locations around PNG, with the successful completion of a pre-sea induction course being a pre-requisite for applying for the Fishing Cadet Course;
- (g) The course content for the Fishing Cadet Course be more focused on fishing technology and fishing operations with more time spent at sea learning basic seamanship skills; other subject areas like mechanics, carpentry, refrigeration and on-shore processing be offered as separate, individual, specialised courses;
- (h) NFA and NFC as part of their forward planning, look at developing specialised training courses for Fishing Cadets who have been in the industry and want to increase their skills, particularly in the fields of boat building, engineering, refrigeration, Masterfisherman, post-harvest operations, and advanced navigation;
- (i) In line with recommendation (h) above, NFC tutors be given additional training to gain necessary qualifications to be able to teach specialised courses, being mindful that some expatriate or other national tutors may be required to run some courses while the NFC tutors receive training;
- (j) NFA and NFC include purse-seining in the curriculum for the Fishing Cadet Course, and purchase materials to construct a small purse-seine net for practical demonstration and use by the students;
- (k) NFA and NFC either drop gillnetting and beach-seining from the Fishing Cadet Course curriculum, or at least greatly reduce the amount of emphasis on these methods, allowing more emphasis to be placed on the main commercial fishing methods in PNG, such as tuna longlining and purse-seining;

- (l) If gillnetting and beach-seining are maintained in the curriculum of the Fishing Cadet Course, better fishing locations be identified, probably with the permission of local villagers, to make this training more meaningful;
- (m) NFA and NFC consider a bonus payment scheme for the skipper and crew of FTV *Leilani* based on catches attained in order to encourage them to present a more commercial attitude when the students are completing their at-sea practical training;
- (n) NFC should either have qualified persons on stand-by or train some of the present staff to be able to operate and maintain FTV *Leilani* in the event that the skipper or engineer are unable to take the vessel to sea;
- (o) The fishing master/skipper and engineer of the FTV *Leilani* build up a stock of fishing gear and spare mechanical parts for the boat, including bait and ice for fishing operations, before each training course;
- (p) The ice machine be removed from FTV *Leilani* to free up deck space, and either sold, or set up onshore;
- (q) A suitable ice machine, whether the old one from FTV *Leilani* or a new one, be set up at the waterfront workshops to make and store ice for practical fishing operations;
- (r) Regardless of the brand of ice machine used, a supplier of appropriate spare parts be located and basic spares ordered and stored at NFC;
- (s) As a matter of priority, FTV *Leilani* be surveyed and all safety equipment checked and updated before practical fishing training is undertaken with the next group of students;
- (t) NFC purchase a VHF radio and establish a base station at the college for regular and emergency, two-way communication with FTV *Leilani* during all fishing operations; and
- (u) NFA and NFC continue to work closely with the PNG Fishing Industry Association to ensure that training needs for the fishing industry are being addressed.

8. REFERENCES

- ANON. (1998). Strengthening and Training Project for the National Fisheries College, Papua New Guinea, AusAID report. 48 p.
- ANON. (1996a). Tuna Fishing Agreements between the State of Papua New Guinea and Foreign Fishing Companies. Papua New Guinea Government. 95 p.
- ANON. (1996b). Strengthening National Capacity for Fisheries Conservation and Management, Papua New Guinea, FAO report. 48 p.
- ANON. (1995). Curriculum for the Certification in Tropical Fisheries, National Fisheries College, Department of Fisheries and Marine Resources, Papua New Guinea. 44 p.
- ANON. (1988). Papua New Guinea Country Report 1987 (confidential). Tuna and Billfish Assessment Programme Country Report No. 1. South Pacific Commission, Noumea, New Caledonia. 23 p.
- ANON. (1981). Tuna Cannery Impact in Kavieng, ARUP Economic Consultants, London. 120 p.
- BEVERLY, S. & L. CHAPMAN. (1996). Capture Section Report of tuna fisheries development, East New Britain, Papua New Guinea (Phase I: FAD deployment project (15 November 1992 to 31 May 1993) and Phase II: pilot tuna longline project (1 June 1993 to 13 September 1994)). South Pacific Commission, Noumea, New Caledonia. 81 p.

- CECILY, P. (unpublished). Consultant report on Informal Education and Training in the Fisheries Sector, Papua New Guinea. 4 p.
- GATES, P., P. CUSACK & P. WATT. (1996). South Pacific Commission fish aggregating device (FAD) manual. Vol. II: Rigging deep-water FAD moorings. South Pacific Commission, Noumea, New Caledonia. 43 p.
- LAWSON, T. (1996). South Pacific Commission Tuna Fisheries Yearbook. South Pacific Commission, Noumea. 92 p.
- LIPSCOMB, A., R. MCKINNON & J. MURRAY (1998). Lonely Planet Guide to Papua New Guinea. Australia. 377 p.
- PETAIA, S. & L. CHAPMAN. (1997). Capture Section Report of fish aggregating device (FAD) site survey, construction and deployment assistance to the Fisheries Department of Tuvalu (Phase I: 7 to 24 October 1995, and Phase II: 17 May to 7 June 1996). South Pacific Commission, Noumea, New Caledonia. 30 p.
- WARE, M. (unpublished). A Modular Approach to Integrated Fisheries Training. National Fisheries College, Papua New Guinea. 19 p.
- WELLINGTON, P. (unpublished). Masterfisherman Visit to National Fisheries College, Papua New Guinea. 16 p.

Specifications of FTV *Leilani* and the electronics on board

Specifications	
Moulded length	15.9 m
Overall length (bowsprit and landing platform)	17.1 m
Beam at transom	4.2 m
Beam midships	4.9 m
Dimensions of shaft	7 cm stainless steel
Dimensions of the propeller	4 blade 94 x 86 cm
Main engine	Caterpillar 3406B
Main engine H.P.	491 H.P.
Main engine voltage	24 V DC
Electrical generator	12 KVA
Gearbox ratio	2.636 : 1
Fuel tank capacity	4 x 1,100 l and 2 x 500 l
Water tank capacity	1 x 800 l
Oil tank capacity	1 x 230 l

Wheelhouse electronics

JRC colour plotter model NWU-52 A;
 JRC global positioning system (GPS) model JLR-4500;
 JRC radar model JMA-320K;
 JRC paper echo-sounder model JFF-620;
 JRC video colour echo-sounder model JFV-120;
 Taiyo Simrad automatic digital direction finder (RDF) model TD-L1100;
 GMZ Electronics VHF marine transceiver model GX558; and
 Barrett VF transceiver model 550.

Repairs undertaken on FTV *Leilani* during this assignment

- Changed main engine fuel filters
- Changed generator fuel filters
- Changed oil and filters
- Replaced V-belts for bilge pump
- Replaced batteries
- Repaired hand bilge pump
- Repaired freshwater pump
- Replaced hydraulic hoses to longline reel
- Replaced hydraulic hoses to trap hauler
- Replaced hydraulic hoses to trawl winch
- Repaired trawl winch cables
- Replaced hydraulic control valve cable
- Replaced electric motor of ice machine
- Rewired ice machine
- Repaired relay switch for ice machine
- Replaced V-belts for ice machine
- Replaced stern-deck floodlights
- Replaced navigation lights

Catch data for fishing operations by fishing method

1. Trolling

Date	Trip number	Number of lines	Estimated hours fished	Catch (kg)
17/06/98	1	6	2	5
18/06/98	2	6	2	78
24/06/98	3	6	2	3
25/06/98	4	6	2	2
1/07/98	5	6	2	75
9/07/98	6	6	2	51
21/10/98	7	6	2	140
22/10/98	8	6	2	nil
28/10/98	9	6	2	nil
29/10/98	10	6	2	nil
4/11/98	11	6	2	110
Total	11	6	22	464

2. Vertical dropline

Date	Trip number	Number of sets	Estimated hours fished	Catch (kg)
17/06/98	1	7	2	10
18/06/98	2	6	2.5	59
24/06/98	3	6	3	64
25/06/98	4	7	3.5	65
21/10/98	5	6	2	10
27/10/98	6	8	4	62
28/10/98	7	8	4	64
Total	7	48	21	334

3. Bottom Handreel

Date	Trip number	Number of lines	Estimated hours fished	Catch (kg)
1/07/98	1 (2 days)	4	13	196
8/07/98	2 (2 days)	4	15	325
26/10/98	3 (1 day)	4	3	51
3/11/98	4 (2 days)	4	14	454
16/12/98	5 (1 day)	4	9	175
Total		4	54	1,201

4. Handline

Date	Trip number	Number of lines	Estimated hours fished	Catch (kg)
11/08/98	1	6	6	96
19/08/98	2	6	7	214
26/08/98	3	6	4	nil
3/09/98	4	6	8	65
11/11/98	5	6	5	75
18/11/98	6	6	5	50
19/11/98	7	6	4	90
25/11/98	8	6	4	48
3/11/98	9	6	3	58
9/12/98	10	6	5	60
Total	10	6	51	756

5. Tuna Longline

Date	Positions		Number of hooks	Yellowfin catch		Other catch (kg)	
	Lat.(S)	Long.(E)		No.	Kg	No.	Kg
15/07/98	02° 45.00'	150° 32.50'	200	2	67	1	11
16/07/98	02° 53.00'	150° 43.00'	200	7	202	1	6
22/07/98	02° 55.00'	150° 40.00'	200	8	247	9	74
23/07/98	02° 56.00'	150° 40.00'	200	11	341	2	12
29/07/98	02° 55.30'	150° 39.70'	200	38	993	2	7
30/07/98	02° 55.00'	150° 39.75'	200	8	203	1	7
5/08/98	02° 43.30'	150° 11.00'	200	2	55	10	81
6/08/98	02° 55.00'	150° 40.00'	200	7	221	3	22
22/08/98	02° 55.00'	150° 41.00'	200	14	416	1	5
11/11/98	02° 54.50'	150° 39.85'	200	3	110	–	–
18/11/98	02° 54.20'	150° 42.00'	200	1	52	1	150
19/11/98	02° 42.00'	150° 05.00'	200	2	62	1	32
25/11/98	02° 10.17'	150° 20.50'	200	–	–	4	54
26/11/98	02° 28.00'	150° 05.00'	200	3	35	4	28
3/12/98	02° 49.90'	150° 51.90'	200	–	–	–	–
4/12/98	02° 59.40'	150° 39.37'	200	6	272	–	–
Total			3,200	112	3,276	40	489

6. Gillnet

Date	Trip number	Number of sets	Catch (kg)
12/08/98	1	2–4 nets	5
19/08/98	2	1–4 nets	–
9/12/98	3	1–8 nets	–
16/12/98	4	1–8 nets	–
Total	4		5

7. Beach-seine

Date	Trip number	Number of sets	Catch (kg)
26/08/98	1	5	90
3/09/98	2	4	20
24/12/98	3	2	30
31/12/98	4	2	20
Total	4	13	160

8. Prawn Trawl

Date	Trip number	Number of sets	Catch (kg)
26/0898	1	2	-
3/09/98	2	2	-
24/12/98	3	1	-
31/12/98	4	2	-
Total	4	7	-

Data collection forms

1. Trolling, vertical dropline, bottom handreel and handline operations

Location:	Trip No:
Time out:	Time in:
Fishing method: Trolling: Vertical dropline: Bottom fishing:	Hours fished: Trolling: Vertical dropline: Bottom fishing:
Number of hooks: Trolling: Vertical dropline: Bottom fishing:	Weather:
Fish caught:	Comments:

2. Tuna longline operations

Location:	Trip No:
Fishing method: Tuna longline:	Number of hooks:
Set start position: Set finish position:	Haul start position: Haul finish position:
Time: Set: Haul:	Weather:
Fish caught:	Comments:

Species composition of the vertical dropline and bottom handreel catch

Family Species English name	Vertical dropline No.	Weight (kg)	Bottom handreel No.	Weight (kg)	No.	Total Weight (kg)
<u>DEEP-WATER SNAPPERS</u>						
LUTJANIDAE (sub-families ETELINAE, APSILINAE)						
<i>Aphareus rutilans</i> Small-tooth jobfish/silvermouth			30	70	30	70
<i>Etelis carbunculus</i> Short-tailed red snapper	13	115	24	103	37	218
<i>Etelis coruscans</i> Longtail snapper	8	11	17	62	25	73
<i>Pristipomoides flavipinnis</i> Yellow jobfish	10	18	139	87	149	105
<i>Pristipomoides filamentosus</i> Rosy jobfish	7	4	29	15	36	19
<i>Pristipomoides multidentis</i> Large-scale jobfish	26	92	121	445	147	537
<i>Pristipomoides auricilla</i> Brown jobfish	4	2	14	8	18	10
<i>Pristipomoides zonatus</i> Banded jobfish			17	14	17	14
<i>Pristipomoides sieboldii</i> Lavender jobfish			11	6	11	6
<i>Paracaesio kusakarii</i> Green banded snapper	19	38	59	60	78	98
<i>Lipocheilus carnolabrum</i> Tang's snapper	8	21	24	49	32	70
Sub-total	95	301	485	919	580	1,220
<u>SHALLOW-WATER SNAPPERS</u>						
LUTJANIDAE (sub-family LUTJANINAE)						
<i>Lutjanus bohar</i> Red bass			3	8	3	8
<i>Lutjanus erthyropterus</i> Crimson snapper			1	2	1	2
<i>Lutjanus rivulatus</i> Maori sea perch			2	7	2	7
<i>Lutjanus malabaricus</i> Large-mouth sea perch			28	39	28	39
<i>Lutjanus monostigma</i> One-spot snapper			2	2	2	2
Sub-total			36	58	36	58
<u>EMPERORS</u>						
LETHRINIDAE						
<i>Lethrinus chrysostomus</i> Red-throat sweetlip			5	3	5	3
<i>Lethrinus miniatus</i> Long-nose sweetlip			3	15	3	15
<i>Lethrinus semicinctus</i> Black-spot sweetlip			2	2	2	2
Sub-total			10	20	10	20

GROUPERS, CODS, CORAL TROUTS

SERRANIDAE

<i>Cephalopholis aurantius</i> Rock cod			8	20	8	20
<i>Cephalopholis sonnerati</i> Tomato cod			3	9	3	9
<i>Epinephelus malabaricus</i> Flowery grouper			9	13	9	13
<i>Epinephelus morrhua</i> Curve-banded grouper			7	16	7	16
<i>Epinephelus maculatus</i> Spotty cod			16	48	16	48
<i>Variola louti</i> Lunar-tail trout			3	3	3	3
Sub-total			46	109	46	109

JACKS AND TREVALLIES

CARANGIDAE

<i>Caranx lugubris</i> Black trevally			6	24	6	24
<i>Caranx ignobilis</i> Giant trevally	1	5	2	14	3	19
<i>Seriola dumerili</i> Deep-water amberjack			1	7	1	7
<i>Seriola rivoliana</i> Deep-water amberjack	3	18	15	50	18	68
Sub-total			4	23	24	118
TOTAL			99	324	601	1,201
					700	1,525

Species composition of the troll and longline catch

Family Species English name	Trolling		Longline		Total	
	No.	Weight (kg)	No.	Weight (kg)	No.	Weight (kg)
<u>MACKERELS, TUNAS AND OTHERS</u>						
THUNNIDAE SCOMBRIDAE & OTHERS						
<i>Euthynnus affinis</i> Mackerel tuna	23	22			23	22
<i>Katsuwonus pelamis</i> Skipjack tuna	120	293			120	293
<i>Xiphias gladius</i> Swordfish			1	18	1	18
<i>Acanthocybium solandri</i> Wahoo			1	6	1	6
<i>Thunnus albacares</i> Yellowfin tuna	45	125	112	3,276	157	3,401
<i>Coryphaena hippurus</i> Mahi mahi	4	22	19	118	23	140
<i>Istiophorus platypterus</i> Sailfish			9	114	9	114
<i>Makaira indica</i> Black marlin			1	62	1	62
<i>Sphyrna barracuda</i> Barracuda	1	2	6	21	7	23
<i>Alopias pelagius</i> Thresher shark			1	150	1	150
TOTAL	193	464	150	3,765	343	4,229