



Pacific Public Health Surveillance Network

Infection Prevention and Control Guidelines



2 0 1 0



**PACIFIC PUBLIC HEALTH SURVEILLANCE
NETWORK (PPHSN)**

**INFECTION PREVENTION AND CONTROL
GUIDELINES**

2010



PREPARED BY MARGARET LEONG

Secretariat of the Pacific Community
Noumea, New Caledonia, 2010

© Copyright Secretariat of the Pacific Community 2010

All rights for commercial / for profit reproduction or translation, in any form, reserved. SPC authorises the partial reproduction or translation of this material for scientific, educational or research purposes, provided that SPC and the source document are properly acknowledged. Permission to reproduce the document and/or translate in whole, in any form, whether for commercial / for profit or non-profit purposes, must be requested in writing. Original SPC artwork may not be altered or separately published without permission.

Original text: English

Secretariat of the Pacific Community Cataloguing-in-publication data

Leong, Margaret

Infection prevention and control guidelines: 2010 / prepared by Margaret Leong

1. Infection — Prevention — Oceania.
2. Communicable diseases — Prevention — Oceania.

1. Leong, Margaret II. Title III. Secretariat of the Pacific Community

614.440995

AACR2

ISBN: 978-982-00-0379-8

Secretariat of the Pacific Community

BP D5, 98848 Noumea Cedex

New Caledonia

Telephone: +687 26 20 00

Facsimile: +687 26 38 18

E-mail: spc@spc.int

<http://www.spc.int>

Published by the Secretariat of the Pacific Community
with financial assistance from AusAID and NZAID
(through Pacific Regional Influenza Pandemic Preparedness Project)

Coordinated by Christelle Lepers

Inside design and layout: Muriel Borderie - Cover: Jipé Le-Bars - SPC Publications section

Printed by Ultimo Ltd, Auckland, New Zealand



CONTENTS

FOREWORD	vi
ACKNOWLEDGEMENTS.....	vii
LIST OF ABBREVIATIONS	viii
GLOSSARY	ix
1 INTRODUCTION	1
1.1 Background	1
1.2 Purpose.....	1
1.3 Objectives	1
1.4 Guidelines use	2
2 INFECTION CONTROL PROGRAMME.....	3
2.1 What is an infection control programme?	3
2.2 Monitoring and evaluating an infection control programme.....	4
2.3 Organising an infection control programme.....	4
2.4 Infection control nurse	7
2.5 Infection control guidelines	7
2.6 Education and training of healthcare workers, patients and visitors	7
3 GUIDELINES FOR MANAGING OCCUPATIONAL EXPOSURE TO BLOOD AND BODY SUBSTANCES FOR HIV AND HEPATITIS B	10
3.1 Introduction	10
3.2 HIV.....	10
3.3 Exposure to hepatitis B virus	10
3.4 Exposure to hepatitis C virus	11
3.5 Tuberculosis	11
3.6 Meningococcal meningitis	11
3.7 Tetanus.....	12
3.8 Work restrictions.....	12
3.9 Guidelines for managing occupational exposures to blood and body substances, including HIV prophylaxis in healthcare settings.....	15
4 INFECTION CONTROL PRACTICES	25
4.1 Hand hygiene	25
4.2 Respiratory hygiene and cough etiquette	29
4.3 Personal protective equipment	29
4.4 Additional (transmission-based) precautions.....	33
5 SAFE HANDLING AND DISPOSAL OF SHARPS	36
5.1 Introduction	36
5.2 Responsibility for sharps.....	36
5.3 Sharps containers	36
5.4 Needle stick injuries	36

6	ENVIRONMENTAL MANAGEMENT PRACTICES	37
6.1	Introduction	37
6.2	Water	37
6.3	Ensuring a safe and adequate water supply	37
6.4	Water disinfection	37
6.5	Collecting rainwater using a roof catchment system.....	38
6.6	Providing protection to wells used for drinking water	40
7	CLEANING THE HEALTHCARE ENVIRONMENT	42
7.1	Introduction	42
7.2	Important housekeeping practices	42
7.3	Cleaning spills of blood and other body fluids.....	44
7.4	Proper disposal of loose sharps	44
7.5	Colour coding cleaning equipment.....	44
8	HEALTHCARE LAUNDRY MANAGEMENT	45
8.1	Introduction	45
8.2	Using personal protective equipment	45
8.3	Collecting and transporting soiled linen.....	45
8.4	Sorting soiled linen.....	46
8.5	Laundering linen.....	46
8.6	Laundry staff	46
9	CLEANING, DISINFECTING AND STERILISING EQUIPMENT AND INSTRUMENTS.....	47
9.1	Introduction	47
9.2	Cleaning	48
9.3	Disinfection	50
9.4	Sterilisation	50
10	FOOD SAFETY.....	54
10.1	Introduction	54
10.2	Food services hygiene	54
10.3	Preparing and serving food.....	55
10.4	Preventing contamination.....	55
10.5	Food storage.....	56
10.6	Thawing food.....	56
10.7	Chilling hot food	57
10.8	Cleaning requirements.....	57
11	HEALTHCARE WASTE MANAGEMENT.....	59
11.1	Introduction	59
11.2	Categories of healthcare waste	59
11.3	Colour-coding or labelling containers	60
11.4	Safe collection of general waste	60
11.5	Safe collection and disposal of infectious and/or clinical waste	61
11.6	Handling healthcare waste bags.....	63
11.7	Scavenging.....	63
11.8	Methods of solid waste disposal	63

11.9	Building and using a simple stove for burning wastes	64
11.10	Waste disposal by burying	67
11.11	Garbage storage and disposal	68
12	INFECTIONS CAUSED BY ANTIMICROBIAL-RESISTANT ORGANISMS	69
12.1	Introduction	69
12.2	Methicillin- and vancomycin-resistant Staphylococcus aureus	69
12.3	Vancomycin-resistant Enterococcus.....	69
13	INFECTIONS BY SELECTED DISEASES	71
13.1	Dengue fever, malaria and leptospirosis.....	71
13.2	Malaria	73
13.3	Leptospirosis	73
14	MYCOBACTERIUM TUBERCULOSIS	75
14.1	Introduction	75
14.2	When TB is infectious.....	75
14.3	Infection control strategies	75
14.4	Multi-drug resistant TB.....	76
14.5	TB and HIV.....	76
14.6	Protection of healthcare workers.....	77
15	HUMAN INFLUENZA, AVIAN INFLUENZA INFECTING HUMANS, AND PANDEMIC INFLUENZA	78
15.1	Human influenza	78
15.2	Avian influenza infecting humans	78
15.3	Pandemic influenza	79
15.4	Infection control principles to slow a pandemic virus	79
15.5	Infection control in the community setting	79
	BIBLIOGRAPHY	80
ANNEX 1:	OCCUPATIONAL EXPOSURE REPORT FORM.....	82
ANNEX 2:	CONSENT FORM FOR POST-EXPOSURE PROPHYLAXIS	84
ANNEX 3:	HIV COUNSELLING FORM CHECKLIST.....	85
ANNEX 4:	POSITION DESCRIPTION	87
ANNEX 5:	HOW TO MAKE AN ALCOHOL HANDRUB.....	88
ANNEX 6:	HOW TO PREPARE SODIUM HYPOCHLORITE SOLUTION FOR DISINFECTION	89
ANNEX 7:	EQUIPMENT LIST FOR ISOLATION ROOMS AND WARDS.....	90

FOREWORD

Infection prevention and control (IP&C) strategies, from systematic hand washing or sanitising and proper waste handling to patient isolation or personal protective equipment use, allow us to limit or avoid many common infections in health-care settings and deal with existing or re-emerging outbreaks like diarrhoeal diseases or measles. IP&C measures are crucial in many epidemic situations.

These measures were re-emphasised during the SARS¹ epidemic in 2003, where about half of the cases were due to transmission in health-care settings. With epidemiology helping us to understand the major routes of transmission, IP&C measures are our first weapon against epidemics of lethal diseases like those causing hemorrhagic fevers, or when we face an unknown emerging disease with severe potential.

While most of the Pacific Islands do not directly face such threats, intercontinental air travel allows anybody from nearly any remote place on the planet to travel to our islands in a couple of days – fast enough for someone infected by an emerging or re-emerging epidemic disease to initiate travel without any symptoms while incubating the disease and become sick while flying to our shores or after arrival. To summarise, we are living in an interconnected world, which allows any disease to quickly travel with people around the planet.

During the first wave of pandemic influenza A (H1N1) 2009, IP&C was clearly at the forefront of the fight, along with other non-pharmaceutical public health measures, including respiratory hygiene and cough etiquette, contact quarantine and home isolation of sick patients, early triaging and use of personal protective equipment (masks in particular). These measures aimed at minimising the spread of influenza A (H1N1) among the susceptible population and in particular patients and health care workers at health care facilities.

Infection control is one of the five key areas identified in the Asia–Pacific Strategy for Emerging Diseases, in line with the new World Health Organization (WHO) International Health Regulations 2005, and expert colleagues from WHO have also contributed to improving the present document.

Although IP&C practices are well in place in some Pacific Island countries and territories (PICTs), they need to be further strengthened in others. To make the sharing of resources easier and stimulate the systematic development of IP&C practices in a sustainable way, the Pacific Infection Control Network (PICNet) was launched in 2006 following recommendations by PICT representatives during after-SARS Pacific Public Health Surveillance Network (PPHSN) meetings. These PPHSN Infection Prevention and Control Guidelines are part of this initiative: they include updated information on IP&C and can be adapted by any PICT wishing to do so.

From the point of view of health service delivery, IP&C extremely important, as health systems must protect their patients and health care workers from diseases they are supposed to combat. Each health system MUST have an IP&C programme, with an IP&C committee for coordinating, monitoring and evaluating the programme, a designated person (e.g. Infection Control Nurse) in each health care facility responsible for implementing infection prevention policies and activities, and guidelines accessible to health staff.

Dr Tom Kiedrzyński

Epidemiologist

Public Health Surveillance and Communicable Disease Control Section

Public Health Division, Secretariat of the Pacific Community

1. severe acute respiratory syndrome



ACKNOWLEDGEMENTS

This regional Infection Prevention and Control Guidelines is the first such set of guidelines produced by the Secretariat of the Pacific Community (SPC) for Pacific Island countries and territories. Ms Peta-Anne Zimmerman — short-term infection control specialist for SPC (from the end of 2005 through the beginning of 2006) — initiated the first draft of the guidelines within the framework of the Pacific Public Health Surveillance Network (PPHSN).

The guidelines have been kept simple and practical, and it is envisaged that they will be used as a reference for countries to develop infection prevention and control guidelines that are tailored to suit their unique healthcare environments.

SPC is grateful to Fiji's Ministry of Health for the use of their Infection Control Manual for Health Facilities 2002. In addition, many of the sections in these guidelines are based on the Fiji Guidelines for Infection Control (2002) and other key documents from relevant health authorities, as listed in the reference list.

I would like to thank Dr Tom Kiedrzyński for providing me with constant feedback throughout the writing process of this document.

I also wish to acknowledge Boris Pavlin (WHO, Pohnpei), Maggy Tomkins (Albion street centre), and Axel Wiegandt and Gary Rogers (SPC) who provided valuable comments on the document.

SPC's appreciation is extended to AusAID and NZAID, the main funders of the Pacific Regional Influenza Pandemic Project (PRIPPP) through which this guideline was further developed.

Margaret Leong

Infection Control Officer for the PRIPP project

LIST OF ABBREVIATIONS

AIDS	acquired immunodeficiency syndrome
BCG	Bacille Calmette–Guerin
HBV	hepatitis B virus
HBsAB	hepatitis B surface antibody
HBsAg	hepatitis B surface antigen
HBeAg	hepatitis B “e” antigen
HBIG	hepatitis B immunoglobulin
HCV	hepatitis C virus
HCW	healthcare worker
HIV	human immunodeficiency virus
HLD	high-level disinfection
MDR-TB	multi drug resistance tuberculosis
MRSA	multi resistant staphylococcus aureus
N95 mask	particulate respirator that filters more than 94% of airborne particles
PEP	post-exposure prophylaxis
PICNet	Pacific regional Infection Control Network
PPE	personal protective equipment
PPHSN	Pacific Public Health Surveillance Network
SARS	severe acute respiratory syndrome
SPC	Secretariat of the Pacific Community
SVM	spiritus vini methylatus (methylated spirits, denatured alcohol)
TB	tuberculosis
WHO	World Health Organization

GLOSSARY

Additional precautions (transmission-based):	Additional or transmission-based precautions are designed for use with patients who are diagnosed with, or are suspected to have, a specific infectious pathogen whose transmission cannot be prevented through standard precautions alone. There are three types of transmission-based precautions: airborne precautions, droplet precautions, and contact precautions.
Airborne transmission:	Transfer of particles containing infectious agents that are disseminated in the air. Micro-organisms carried this way can be widely dispersed via air currents and can remain infectious in the environment for long periods before being inhaled by or deposited onto the susceptible host.
Alcohol hand rub:	A waterless alcohol-based product appropriate for rapid hand decontamination between patient contacts. It is recommended for use when hands are not visibly soiled or contaminated with blood and body fluids.
Avian influenza:	Avian influenza is an infectious disease of birds and is caused by type A strains of the influenza virus.
Contact transmission:	The transmission of infectious agents can be divided into two subgroups: direct contact transmission and indirect contact transmission: <ul style="list-style-type: none"> • Direct contact transmission involves direct physical transfer of micro-organisms from an infected or colonised person to a susceptible host. • Indirect contact transmission involves a susceptible person coming in contact with a contaminated (usually inanimate) object, such as a contaminated instrument or piece of equipment.
Decontamination:	Cleaning an object by either chemical or physical means to reduce the number of micro-organisms on it.
Droplet transmission:	Transfer of infectious agents in the droplets that are generated during coughing, sneezing or talking, and during the performance of certain clinical procedures such as suctioning and bronchoscopy.

Disinfection:	A process that kills or destroys most disease-producing organisms, but rarely kills spores. Disinfectants are used on inanimate objects as opposed to antiseptics, which are used on living tissue.
Hand hygiene:	Refers to hand washing with soap and water, use of alcohol hand rub and antiseptic solutions.
N95 Mask:	A disposable filter mask designed specifically to protect the wearer from exposure to airborne (small particle) infectious diseases such as TB by sealing tightly to the face. It has the capacity to filter 95% of airborne infectious particles from the air.
Nosocomial infection:	(Also known as hospital-acquired infection.) An infection that is acquired during hospital admission as a result of health care interventions.
Occupational exposure:	An incident that occurs during the course of a person's employment and involves contact with blood or body substances. Occupational exposure includes: <ul style="list-style-type: none"> • percutaneous injuries or cuts caused by used instruments, such as needles or scalpel blades, and involving blood or other body substances; • contamination of fresh cuts or abrasions with blood or other body substances; and • contamination of the eyes or other mucous surfaces with blood or other body substances.
Personal protective equipment (PPE):	Gloves, masks, eye protection, gown, caps and aprons worn to protect the wearer from contact with infectious agents.
Surgical mask:	A disposable mask designed to protect the wearer against splashes of bodily fluids, and sprays and droplets generated by coughing and sneezing.
Sterilisation:	A process that destroys all forms of microbial life, including bacteria, viruses, spores and fungi. This method is used for all items that contact normally sterile areas of the body.
Standard precautions:	Precautionary measures designed to reduce the risk of transmission of micro-organisms from both recognised and unrecognised sources of infection in hospitals. Standard precautions involve safe work practices and include the following: hand hygiene, respiratory hygiene/cough etiquette, personal protective equipment, appropriate handling of laundry and appropriate handling of used patient equipment.
Sharps:	Needles, intravenous spikes, lancets, broken ampoules, scalpel blades and any other sharp object that is capable of causing an injury.

1 INTRODUCTION

1.1 Background

Infection control has an integral role in the provision of a safe healthcare environment for both patients and healthcare workers (HCWs) across the continuum of care. Lack of adherence to safe practices or inadvertent exposure to pathogens, including HIV, in the healthcare environment can lead to significant morbidity and mortality in patients and HCWs alike. A safe working environment in the healthcare setting includes the provision of a safe physical environment, the use of safe clinical practices, the availability of adequate resources, the provision of safe equipment and consumable items, and a culture of safety for all. Safety in healthcare also includes mechanisms for reporting events that result from an unsafe environment or practice.

Infection control and prevention, particularly in healthcare facilities, is a critical element in interrupting the transmission of priority infectious diseases in the region. Communication, accessibility of expertise, and technical advice are recognised as areas in need of improvement in facilitating infection control response to infectious disease threats.

1.2 Purpose

The membership of the Pacific regional Infection Control Network (PICNet), under the auspices of the Pacific Public Health Surveillance Network (PPHSN) of the Secretariat of the Pacific Community (SPC), has come together to produce guidelines for the prevention and control of infections in healthcare settings, with a particular focus on the needs of SPC's member states.

These guidelines are based on the Fiji Ministry of Health infection control manual for health facilities (2002) and other key documents from relevant health authorities, as listed in the reference list.

1.3 Objectives

The overall objective of these guidelines is to provide healthcare administrators and HCWs with a framework to prevent and control the transmission of infectious pathogens within, from, or to the healthcare setting, to patients, HCWs and the community alike.

More specifically, these guidelines cover:

- infection control programme management;
- infection control practices to prevent and control the transmission of infectious pathogens through the use of standard and transmission-based precautions;
- environmental management practices to prevent and control transmission on infectious pathogens; and
- protection of HCWs from infectious pathogens.

1.4 *Guidelines use*

These guidelines are generic and should be used in every healthcare facility in the region. As with any generic guidelines, these must be adapted to suit the local situation, whether at a national or local healthcare facility. People responsible for infection prevention and control activities in each member state should visit the PICNet website (<http://www.spc.int/phs/PPHSN/Activities/PICNet.htm>) regularly to stay apprised of updates, particularly with regards to emerging infectious disease threats or changes in practice or research.

2 INFECTION CONTROL PROGRAMME

2.1 *What is an infection control programme?*

An infection control programme is the collective organised activities related to the prevention and control of infectious diseases. An infection control programme can be organised at multiple levels, including the regional, national, state, provincial or local level.

Infection control programmes have proven to be successful in lowering the incidence and spread of infectious diseases provided the programmes are comprehensive, and include surveillance and prevention activities and staff training. It is imperative that support is provided from administrative and authoritative bodies from local to national and regional levels.

The World Health Organization (WHO), in a 2002 report, suggests that an infection control programme should:

- set relevant national objectives consistent with other national healthcare objectives;
- develop and continually update guidelines for recommended healthcare surveillance, prevention, and practice;
- develop a national system to monitor selected infections and assess the effectiveness of interventions;
- harmonise initial and continuing training programmes for healthcare professionals;
- facilitate access to materials and products essential for hygiene and safety; and
- encourage healthcare establishments to monitor healthcare associated infections and to provide feedback to the professionals concerned.

Each healthcare facility is required to:

- develop an infection control programme to ensure the well being of both patients and staff;
- formulate an annual work plan to promote good healthcare, appropriate isolation, sterilisation and other practices, staff training and epidemiological surveillance; and
- provide sufficient resources to support the infection control programme.

The objectives of an infection control programme should be to:

- reduce the incidence and risk of preventable healthcare associated infection;
- prevent infection transmission within healthcare facilities and the community; and
- formulate an organisational framework that assists with the effective use of resources to delivering healthcare in a safe, cost effective and scientifically valid manner.

The components of the infection control programme should include:

- basic measures for infection control (i.e. standard and additional transmission-based precautions);
- education and training of HCWs;
- protection of HCWs;
- identification of hazards and minimising risks;
- routine practices essential to infection control (e.g. aseptic techniques), use of single use

devices, proper reprocessing of instruments and equipment, judicious antibiotic usage, management of occupational exposures to blood and body substances, and safe handling and use of blood and blood products;

- effective work practices and procedures (e.g. environmental management practices such as management of healthcare related waste, support services such as food and linen, use of therapeutic devices);
- surveillance;
- incident monitoring;
- outbreak investigation;
- infection control in specific situations; and
- research

2.2 *Monitoring and evaluating an infection control programme*

Routine monitoring and evaluation of the infection prevention process is important for measuring the programme's effectiveness. Monitoring should be done to answer the following questions:

- Are recommended methods being followed?
- Are needed equipment and supplies available in the hospital or clinic?
- If equipment is available, is it being used correctly?
- Was a training programme effective?
- Are more patients becoming infected?

Monitoring results should be shared with healthcare staff. If the activity was done correctly, then staff should be congratulated. Staff must not be made to feel bad if they have done something wrong. If an activity was not done correctly, then possible reasons should be discussed to see what can be done. It is important to discuss results in the light of the local situation. Consider the available budget for infection control practices and equipment and supplies.

Monitoring and evaluation should be performed every two months via internal audits and reviews of antibiotic resistance reports, reports of suspected nosocomial (hospital-derived) infections, and other reports. Report findings should be presented to national and local infection control committees.

2.3 *Organising an infection control programme*

2.3.1 Infection control committee

Responsibility for coordinating, monitoring and evaluating the infection control programme is delegated by the hospital or healthcare facility management to a group of relevant staff who form an infection control committee. An infection control committee should be formed at all hospitals, as well as at the national level.

The purpose of the infection control committee is to:

- implement and support the use of recommended infection prevention practices;
- develop policies, guidelines and procedures relating to infection control and ensuring their currency and accessibility to staff;
- review problems that may cause infection, and identify areas for intervention by using surveillance and other data;

- assess and promote improved practice at all levels of the healthcare facility;
- ensure appropriate staff training in infection control and safety management, provision of safety materials such as personal protective equipment and products;
- train HCWs;
- ensure that there is a defined programme for healthcare-associated infection surveillance that includes collection, analysis and reporting back of data to departments and clinicians;
- ensure that reports on the occurrence of healthcare-associated infections are received and that actions resulting from these reports are determined and monitored;
- provide guidance, advice and support is given to the infection control nurse; and
- ensure that resources are used efficiently and cost effectively.

Members of the committee should include staff from a variety of departments. For example, the committee might include some or all of the following:

- infection control nurse
- nurse
- doctor
- midwife or doctor working in obstetrics
- administrator
- housekeeper
- operating room staff responsible for sterilisation
- laboratory technician.

The infection control committee should not have more than five to ten members or it becomes unmanageable. However, specialists from various departments (for example, the pharmacist or laundry manager) can be called to meetings when a problem arises in their department, or when they can offer specialised information.

The infection control committee should meet on a routine basis (at least every two months) to discuss infection prevention activities, and to solve problems. In the event of a critical incident or outbreak situation, the committee should be able to convene promptly.

The committee should establish and document “terms of reference” and have these approved by an appropriate authority, such as a senior healthcare administrator or director of health services.

The committee should appoint a secretary and keep records of its activities. An agenda should be prepared and distributed prior to each meeting. Minutes of the previous meeting should be distributed with the agenda.

The agenda should include a:

- review of monitoring activities;
- report on actions taken on problems identified at the last meeting;
- report on training activities and needs;
- list of new problems; and
- set of recommendations for change, if needed, and a list of who will be responsible.

For each agenda item, a designated person should be responsible for preparing a report, and for applying the recommendations for change. At each meeting, the designated person (or people) should report on progress made toward specific goals.

Meeting minutes should adopt a consistent format such as the one below.

1. Present:	List all those present at the meeting
2. Apologies:	List apologies received
3. Minutes of previous meeting:	Confirmation of the minutes of the previous meeting as a true and correct record of proceedings. (Once confirmed, minutes should be signed off by the Chairperson.)
4. Matters arising:	Discussion on any matters arising from previous minutes
5. Reports:	Consideration of reports as circulated or presented to meeting
6. General business:	New business as listed on the agenda or any other matters raised at the meeting
7. Date and time of next meeting:	Enter the agreed upon meeting date and time
8. Meeting closed:	Note the time the meeting closed
9. Signature block:	For the Chairperson to sign once minutes have been confirmed

Meeting minutes should include the following information.

- A brief (few sentences) summary of each agenda item's discussion.
- Recommendations of tasks or actions to solve a problem (e.g. training programme, buying equipment, making posters).
- The name of the person to be responsible for applying the changes recommended, and the date (deadline) by which the person or task group should have carried out the assigned task.
- The results of the actions taken to solve a problem.

Other information to note includes: Was the goal accomplished? If there were problems, were they identified and solved? How were problems solved (e.g. staff were trained in infection control procedures, supplies were purchased)?

Keeping a record of this information will make it easier to solve a similar problem later. Minutes should be written as soon as possible after the meeting.

The committee secretary should maintain the master set of minutes. Minutes should be kept in a folder. Care is needed when handling folders to ensure that pages are not lost.

The infection control committee should decide how infection prevention practices can be applied based on the amount of available equipment. It is important to make decisions that are practical and standard.

Good communication and exchange of ideas with staff can improve work habits and attitudes. Staff should be informed about the infection control committee and the purpose of the programme. Hospital management should share ideas and materials with staff, and be ready to listen to their perspective.

Good communication at all staff levels is the key to a successful infection prevention programme.



2.4 Infection control nurse

Each hospital or healthcare facility should have a designated person responsible for implementing infection prevention policies and activities, and developing methods for reviewing practices to minimise the incidence of infection. This person may be a nurse but may also be any other person with knowledge of infections (e.g. laboratory staff, medical officer). Ideally, this person would have received specialist training in infection control and prevention.

The infection control nurse must be a member of the infection control committee. The infection control nurse's role is to work with all departments to provide an environment free of infection for patients and staff.

The infection control nurse's responsibilities are to:

- coordinate and conduct training activities;
- carry out surveillance activities;
- develop and disseminate infection control policies;
- observe infection control practices and make suggestions for improvement;
- help identify problems and assist in problem-solving; and
- report to the infection control committee at every meeting.

It is generally recommended that there be one full-time equivalent infection control nurse per 125 hospital beds (see sample position description in Annex 4).

2.5 Infection control guidelines

Infection control guidelines assist healthcare staff in preventing the transmission of healthcare associated infections. Sections of the regional guidelines may be adapted to local situations. In such cases, an infection control nurse — in collaboration with an infection control committee — develops the guidelines for the local healthcare facility.

After approval by the infection control committee, the guidelines must be distributed to each department in the facility. The guidelines must be reviewed on an annual basis and changes made in accordance with available evidence-based practice research and information.

2.6 Education and training of healthcare workers, patients and visitors

An infection prevention programme can be successful only when everyone is involved. People are usually willing to change bad habits to good ones when they understand the reasons and the importance of each procedure. Therefore, each healthcare facility should plan frequent in-service education programmes for staff, patients and visitors. In-service training is an ongoing process. In-service training should be used to teach good practices, change bad habits, and demonstrate new equipment or procedures.

Every level of staff (i.e. nurses, doctors, housekeepers, cleaners, students) need to learn the importance of infection prevention. Even workers who have little contact with patients, such as pharmacy or kitchen staff, should be included. All staff are important in preventing infections in the healthcare facility.

All HCWs should:

- understand how infection spreads in the healthcare facility;
- know the important role each staff member plays in preventing infection; and
- be able to describe or demonstrate various methods of preventing the spread of micro-organisms, such as hand hygiene.

The training programme should be made as interesting as possible by using discussion, audio-visual aids, posters, role playing and games. The following programmes should be established.

2.6.1 Orientation

Orientation is a basic programme for all new staff, and should include the principles and methods of preventing the spread of infection within staff members' unit or department. The new employee should have their responsibility in preventing infection explained to them.

2.6.2 In-service education

A programme of frequent in-service education should be planned for all staff, beginning as soon as the infection control guidelines are introduced. Regularly scheduled in-service education workshops can be used to identify and solve problems, introduce new techniques, and provide general reminders about the importance of safe practices to prevent the spread of micro-organisms.

2.6.3 Patient teaching

It is the HCW's responsibility to instruct patients about their role in the prevention of infection or the spread of infection. For example, a HCW may teach patients with respiratory illnesses to cough into a handkerchief, or teach patients with enteric disease to thoroughly wash their hands before and after using the toilet, or teach a patient with a wound to keep it clean and dry.

2.6.4 Visitor teaching

Visitors should be made aware of the risks they pose by spitting in halls, using toilets improperly, crowding around patients, and handling intravenous sets, catheters and other patient care equipment. Every opportunity should be used to give one-on-one education in order to increase visitors' knowledge about infection prevention. An excellent time to educate visitors is when they are waiting in the hospital or clinic. For example, small classes on infection prevention can be given using a video player (if available).

2.6.5 Steps to a successful training programme

In-service education programmes can be short, simple and interesting. In addition, HCWs can be a role model for other staff and patients. Staff and others should be reminded to wash their hands frequently, and perform tasks correctly. A training programme should:

- Clearly identify the group that is being trained (e.g. nurses, community health workers, cleaners, laboratory technicians);
- Be carefully planned. It will be necessary to decide on:
 - **what** will be taught,
 - **how** it will be taught (what teaching aids and supplies are needed),



- **when** it will be taught (making use of a schedule), and
- **where** it will be taught (e.g. in a classroom, on the ward);
- Describe clearly the tasks that staff need to learn at the beginning of the session;
- Determine what they know before you start (it may be more or less than you expect);
- Be realistic: train people to use facilities that are available;
- Give necessary information about the reason for certain procedures and about the consequences of not carrying them out (e.g. infection or even death);
- Make learning interesting by:
 - encouraging discussion,
 - linking information about caring for patients and cleanliness in healthcare facilities with local tradition and beliefs, and
 - using teaching aids such as posters, field trips, role playing, and audio-visual aids;
- Select a teaching method that is best for the specific audience;
- Provide information, examples and training skills;
- Teach skills using practice session of tasks;
- Use case presentations to identify problems, and exchange ideas on how to better handle a given situation;
- Give learners feedback on their practice (in a respectful way) so they will know how well they are doing;
- Evaluate the training by watching learners do the tasks on the job or issue a survey; and
- Use the results of the evaluation to improve training.

3 GUIDELINES FOR MANAGING OCCUPATIONAL EXPOSURE TO BLOOD AND BODY SUBSTANCES FOR HIV AND HEPATITIS B

3.1 Introduction

HCWs are at risk of exposure to blood and body substances, and to infectious diseases. Implementation of preventative measures against infectious diseases, and managing occupational exposure to blood and body substances, will assist in the maintenance of staff health.

The infection prevention issues for HCWs described in this section include:

- human immunodeficiency virus (HIV)
- hepatitis B virus (HBV)
- hepatitis C virus (HCV)
- tuberculosis (TB)
- meningococcal meningitis
- tetanus
- work restrictions
- guidelines for managing occupational exposure to blood and body substances for HIV and hepatitis B.

3.2 HIV

HIV is transmitted from person to person via sexual contact, sharing of needles contaminated with HIV, infusions contaminated with HIV, and transplantation of organs or tissues infected with HIV. The risk of a HCW acquiring HIV after a needle stick or other sharp injury is significantly low, less than 0.5% (1 in 200).

There are no confirmed effective methods of treatment and no cures for HIV, hence the focus must be on preventing exposure to HIV through safe infection control work practices, such as standard precautions, ongoing education and training, safe management, proper disposal of healthcare-related waste and sharps, and use of personal protective equipment. There is no vaccine for HIV.

3.3 Exposure to hepatitis B virus

The transmission route of hepatitis B is through blood and other body substances such as blood products, saliva, cerebrospinal fluid, peritoneal, pleural, pericardial and synovial fluid, amniotic fluid, semen and vaginal secretions.

HBV is one of several viruses that may be transmitted by significant exposure to blood or other body substances. HBV, like HIV, cannot be cured and often results in severe liver damage or death. There is a highly effective vaccine for HBV.



3.3.1 Hepatitis B immunisation

Immunisation is the best way of preventing HBV transmission to healthcare staff, and should be offered to all HCWs.

Hepatitis B immunisation is a series of three injections: an initial injection, an injection given one month after the initial injection, and one given six months after the initial injection.

3.3.2 Antibody testing

Post-immunisation testing for seroconversion should be done three months after the third immunisation dose. All HCWs should be responsible for knowing their immune status.

3.4 Exposure to hepatitis C virus

In the healthcare setting, the transmission route of HCV is largely parenteral (through the skin, through — for example — a needle stick), through exposure to blood and body substances. Sexual transmission does occur, but is far less frequent. As with HIV, there are no confirmed effective methods for treating HCV, hence the focus must be on preventing exposure to HCV through safe infection control work practices (e.g. standard precautions, ongoing education and training, safe management and disposal of healthcare-related waste and sharps, and use of personal protective equipment). There is no vaccine for HCV.

3.5 Tuberculosis

Tuberculosis (TB) is usually transmitted by exposure to airborne particles produced by individuals with pulmonary disease while coughing and/or sneezing. Prolonged close contact with such individuals increases the risk of transmission. The aerosol droplets are very small, less than 5 \times m in diameter, and can stay infectious for long periods in the air, making transmission possible when they are inhaled and settle into the lungs.

General infection control recommendations include the following.

- Bacille Calmette–Guerin (BCG) is given as a childhood vaccination schedule in most nations to prevent severe forms of TB in children; it likely has little protective effect in adults.
- Ongoing education should be provided to all healthcare personnel regarding the recognition, transmission and prevention of TB.
- HCWs working in TB wards, intensive care units, medical nursing staff, mortuary staff, radiographers, physiotherapists, maids and laboratory staff working with TB specimens should be offered baseline Mantoux (PPD / TST / TB skin test) testing and chest x-rays.

Mantoux negative HCWs should be periodically screened and monitored by a TB or respiratory expert. Refer to Section 14 for more information on TB.

3.6 Meningococcal meningitis

Neisseria meningitidis is transmitted via direct contact, particularly by respiratory droplets from the nose or throat of colonised or infected people. Individuals with meningococcal septicaemia (blood poisoning) or meningitis are usually not infectious after 24 hours of appropriate antibiotic therapy.

The risk of transmission is high for HCWs who have been in direct prolonged contact with the patient and have not been wearing personal protective equipment (i.e. masks), or have been involved in mouth-to-mouth resuscitation, intubation or bronchoscopy of infected patients. Antibiotic prophylaxis (treatment to prevent developing symptoms) should be made available to HCWs in these situations if the risk of exposure has been deemed to be significant. No prophylaxis can be considered 100% effective; prevention of exposure should therefore be aimed for.

3.7 Tetanus

Tetanus enters the body through wounds contaminated with soil, human and animal faeces, and street dust. Tetanus vaccinations are given as a childhood vaccination schedule in most nations. A booster vaccination is required every 10 years. Tetanus status should be reviewed in the event of an occupational exposure to blood or body substances, particularly those involving used or discarded sharps or needles, or for deep or dirty wounds. People who haven't had a recent booster should be re-vaccinated.

3.8 Work restrictions

Table 3.1: Work restrictions for healthcare workers exposed to, or infected with, selected infectious diseases

Disease/pathogen	Relieve from direct patient contact	Partial work restriction	Duration
conjunctivitis infectious	Yes		Until discharge ceases
cytomegalovirus Infectious	No		
Diphtheria	Yes		Exclude exposed staff and those identified as asymptomatic carriers from duty until antimicrobial therapy is completed and results of two nasopharyngeal cultures obtained at least 24 hours apart are negative.
gastroenteritis Acute	Yes		Until symptoms resolve and infection with Salmonella is ruled out.
group a streptococcus infections	Assess		Do not routinely exclude personnel unless it is shown epidemiologically that they are responsible for disseminating the organism in the healthcare setting.
hepatitis a	Yes		Until 7 days after onset of jaundice
hepatitis b acute symptoms	Assess		Refer to specialist
chronic antigenemia	Assess	May be restricted from performing exposure prone procedures.	Refer to specialist

Table 3.1: Work restrictions for healthcare workers exposed to, or infected with, selected infectious diseases (continued)

Disease/pathogen	Relieve from direct patient contact	Partial work restriction	Duration
hepatitis c	Assess	May be restricted from performing exposure prone procedures.	Refer to specialist
herpes simplex orofacial or genital	Assess		Assess the potential for transmission to high-risk patients (neonatal intensive care unit patients, patients with severe burns or eczema, and severely immunocompromised patients) and the need for exclusion from the care of such patients. Counsel to cover and not touch the infected lesions, hand hygiene, do not allow the lesions to touch patients with dermatitis.
herpetic whitlow (fingers and hands)	Yes		Exclude until lesions are healed
herpes zoster shingles	Yes	Restrict immunocompetent personnel with localised zoster from the care of high-risk patients until lesions are crusted; allow them to care for other patients with lesions covered.	Restrict immunocompromised personnel with zoster from contact with patients until lesions are crusted. Restrict susceptible personnel exposed to zoster from patient contact from the 10 th day after the first exposure through the 21 st day after the last exposure.
HIV	Assess	May be restricted from performing exposure prone procedures.	Refer to specialist
influenza and other viral respiratory illness including the common cold	Yes		Consider excluding personnel with acute febrile respiratory infections from the care of high risk patients (e.g. neonates, young infants, patients with chronic obstructive lung disease and immunocompromised patients) during community outbreaks of influenza or respiratory syncytial virus (RSV) infections.
measles active	Yes		Until 7 days after the rash appears or for the duration of their acute illness, whichever is longer.
post exposure (susceptible personnel)	Yes		From the 5 th through the 21 st day after the last exposure OR 7 days after the rash appears or for the duration of their acute illness, whichever is longer.

Table 3.1: Work restrictions for healthcare workers exposed to, or infected with, selected infectious diseases (continued)

Disease/pathogen	Relieve from direct patient contact	Partial work restriction	Duration
meningococcal disease	Yes		Exclude personnel with <i>N. meningitidis</i> infections from duty until 24 hours after the start of effective antibiotic therapy. Do not routinely exclude personnel from duty who only have nasopharyngeal carriage of <i>N. meningitidis</i> .
Mumps	Yes		Exclude susceptible personnel who are exposed to mumps from duty from the 12 th day after the first exposure through the 26 th day after the last exposure or, if symptoms develop, until 9 days after the onset of parotitis.
Pertussis	Yes		Exclude personnel in whom symptoms develop (cough ≥ 7 days, particularly if accompanied by paroxysms of coughing, inspiratory whoop, or posttussive vomiting) after known exposure to pertussis from patient care areas until 5 days after the start of appropriate therapy.
Rubella	Yes		Exclude susceptible personnel who are exposed to rubella from duty from the 7 th day after the first exposure through the 21 st day after the last exposure. Exclude personnel who acquire rubella from duty until 7 days after the beginning of the rash.
scabies and pediculosis	Yes		Exclude personnel with confirmed scabies from the care of patients until they have received appropriate treatment and have been shown, by medical evaluation, to have been effectively treated. Exclude personnel with confirmed or suspected louse infestation from contact with patients until after they receive appropriate initial treatment and are found to be free of adult and immature lice.
staphylococcal infection or carriage	Assess		Do not routinely exclude personnel unless it is shown epidemiologically that they are responsible for disseminating the organism in the healthcare setting.
tuberculosis lung or larynx	Yes		Exclude personnel with infectious pulmonary or laryngeal TB from the workplace until the facility has documentation from their healthcare provider that they are receiving adequate therapy, their coughs have resolved, and that they have had three consecutive sputum smears collected on different days with negative results for acid fast bacilli (AFB). After personnel return to work, obtain periodic documentation from their healthcare provider that effective drug therapy has been maintained for the recommended period and that sputum smear results AFB negative.

Table 3.1: Work restrictions for healthcare workers exposed to, or infected with, selected infectious diseases (continued)

Disease/pathogen	Relieve from direct patient contact	Partial work restriction	Duration
other sites	Assess		Do not exclude personnel from the workplace who have TB only at sites other than the lung or larynx.
Varicella	Yes		Exclude personnel from work who have onset of varicella until all lesions have dried and crusted. Exclude from duty after exposure to varicella personnel who are not known to be immune to varicella (by history or serology), beginning on the 10 th day after the first exposure until the 21 st day after the last exposure.

Source: CDC 1998

3.9 *Guidelines for managing occupational exposures to blood and body substances, including HIV prophylaxis in healthcare settings*

Occupational exposure is defined as an incident that occurs during the course of a person's employment and involves contact with blood or body substances. Such exposure may put the person at risk of acquiring a bloodborne infection.

Adherence to standard infection control practices remains the first line of protection for HCWs against occupational exposure to HIV, HBV and HCV.

These guidelines are for governments and other agencies involved with the delivery of healthcare and tasked with the responsibility for health and safety at work.

Policies should cover all people in a healthcare setting, including all staff and visitors such as clinical staff, non-clinical staff (e.g. administrators, house keeping and laundry staff, maintenance workers), laboratory staff, volunteers, private contractors and consultants.

3.9.1 **Prevention of occupational exposure**

Preventing exposure — through safer practices, barrier precautions, safer needle devices and other methods — remains the most effective strategy for reducing the risk of infection with HIV and other bloodborne pathogens in healthcare settings.

Two significant prevention priorities are that all 1) HCWs should be trained in, and be able to demonstrate competency in, standard precautions; and 2) staff should be provided with the necessary materials and protective equipment.

Staff should also be knowledgeable about the risks of acquiring HIV and other blood borne pathogens sexually, and should have ready access to condoms and confidential sexually transmitted infection treatment services.

The following measures aimed at reducing the incidence of occupational exposures should be taken.

- Never recap needles.
- Do not disconnect needles from the syringe.
- Always transport (or pass to another person) sharp objects in a kidney dish or puncture-proof container.
- Sharps should be disposed of in puncture-proof containers.
- Take care with all blood contaminated equipment.

All employers must ensure that the following management strategies are implemented.

- An efficient system for reporting and managing potential exposures of HCWs to blood and body substances;
- Confidentiality of injured HCWs is maintained;
- Expert advice is available to all HCWs 24 hours a day, and that processes are in place to facilitate ready access to appropriate treatment;
- Rapid assessment of HCWs is available to ensure timely administration of specific prophylaxis, if appropriate; and
- All occupational exposures are fully documented to meet regulatory requirements.

3.9.2 Definition and reporting of occupational exposure

Occupational exposure includes:

- percutaneous injuries or cuts with used instruments, such as needles or scalpel blades, and involving blood or other body substances;
- contamination of fresh cuts or abrasions with blood or other body substances; and
- contamination of the eyes or other mucous surfaces with blood or other body substances.

Procedures for reporting occupational exposures are as follows:

- The HCW should IMMEDIATELY report the exposure to their supervisor or manager (24 hours per day).
- The supervisor should arrange immediate medical assessment (24 hours per day) of the HCW and the patient who is the “source” of the exposure.
- Complete an exposure report. An exposure report should contain the following information:
 - The name of the staff member involved.
 - Area where the incident occurred such as the ward, operating room or emergency room.
 - A description of the incident.
 - The name of the source person whose blood or body substances were involved in the incident.
 - If the source of the blood is unknown this must also be documented.

As soon as possible (within one day), a copy of the incident form should be sent to the infection control nurse (or equivalent) and the exposed HCW’s supervisor, so that they can be aware of any standard precaution procedural risks or lapses, in a confidential, sensitive and non-judgmental way.

3.9.3 Medical assessment

A medical risk assessment involves taking and recording the history and details of the occupational exposure and assessing the risk for HIV, HBV and HCV from the source person and the exposed person. This assessment should be undertaken by a trained person IMMEDIATELY



after first aid is given, REGARDLESS OF WHAT TIME OF DAY THE OCCUPATIONAL EXPOSURE OCCURS. Information to be examined during the assessment includes:

- date, time and location of the exposure;
- duty being performed at time of exposure;
- how exposure occurred;
- protective clothing such as gloves being worn at time of incident;
- nature of exposure such as percutaneous, mucous membrane non-intact skin;
- type and volume of blood and/or body substances exposed to;
- duration of contact with blood and/or body substances;
- if a sharps injury: type of implement involved, whether it was visibly contaminated with blood, depth of injury, if bleeding occurred;
- if a needle stick injury: needle gauge, syringe size, purpose for which needle had been used;
- if non-intact skin: condition of skin;
- HIV, HBV and HCV status of the source (if known); and
- HBV immunity and vaccination history of the exposed person.

3.9.4 Exposure and source patient

Exposure should be assessed for its potential to transmit a bloodborne pathogen (based on body substance and severity of exposure). Source identification and testing is only necessary if the results will change the clinical management of the exposed worker. If the exposure is assessed as having no or low risk of HIV transmission, then post exposure prophylaxis for HIV should not be prescribed. This is regardless of whether the source person is known to be HIV positive or not. In low risk exposures, testing the source patient is not required or necessary. If testing a source patient of unknown status is required, it should only occur after obtaining informed consent, and should include appropriate pre-test counselling and a referral plan for care, treatment and support. Confidentiality must be maintained throughout the process.

Medical assessment constitutes an emergency for the exposed HCW. Assessment should include “baseline tests” on a venous blood specimen from the HCW.

Baseline testing is done at this time to ascertain whether the exposed person has been infected from a previous exposure at the time of the incident. Some guidelines follow.

- Baseline testing should occur immediately (after first aid has been completed) following exposure, but at least within 72 hours.
- Baseline tests are usually HIV antibody, hepatitis B surface antigen (HbsAg) and hepatitis B and C antibodies.
- The HCW’s tetanus immunisation status should be considered.
- Pre-test counselling for HIV should occur before any blood is taken for testing (but blood drawing should not be delayed if an appropriate counsellor cannot be located right away).
- Follow-up retesting for HIV, HBV and HCV should occur at six weeks and three months. There is also a six-month follow up for HIV and HCV only.

Clinical evaluation and baseline testing of the exposed HCW, which should proceed only after pre-test counselling and after obtaining informed consent, should always include a/an:

- explanation of privacy and confidentiality;
- review and, if necessary, further explanation of HIV, HBV and HCV infection and its consequences;
- explanation of testing, possible results and confirmatory testing;
- assessment of risk related to past and current sexual and other behaviour;

- assessment of risk related to the occupational exposure in question;
- explanation of low transmission risk associated with occupational exposure;
- assessment of anxiety level and coping mechanisms;
- informed consent for testing;
- informed consent for pregnancy test (if indicated);
- plan for precautions while awaiting test results (and while on PEP, if indicated): adverse effects of antiretrovirals (ARVs), safer sexual practices or abstinence, cessation of breast feeding if lactating'
- list of any other risks identified by sexual and behavioural history;
- mechanism for support while patient waits for test results, and while on PEP if indicated; and
- review of the sequence of events that preceded the exposure, and provide exposure risk reduction education in a sensitive and non-judgmental way.

3.9.5 Risk of HIV and other infections following occupational exposure

Data from several studies of HCWs exposed to HIV in the work place suggest that the risk of HIV transmission after percutaneous exposure to HIV-infected blood is approximately 0.3% (95% confidence interval [CI] 0.2 to 0.5%).

Risks towards the higher range are associated with exposures such as:

- a deep injury;
- visible blood on the “sharp” device causing the injury;
- a hollow-bore needle (as opposed to a solid one);
- injury by a needle that was previously used in the patient’s vein or artery; and
- a high viral load on the part of the patient (either acute or late-stage HIV infection or, if being managed at a specialist centre overseas, a known high viral load).

The risk of transmission from a “sharp” object contaminated with other infected body fluids or tissues is believed to be lower than for exposure to infected blood.

After a mucous membrane (eye, nose or mouth) exposure to HIV-infected blood, the risk is approximately 0.09% (95% CI 0.006 to 0.5%).

For a person unvaccinated against hepatitis B, the risk after percutaneous exposure is 23–37% if the source person is HBeAg negative, and 37–62% if the source person is HBeAg positive. Infection with hepatitis B is possible following mucous membrane exposure but has not been quantified.

The risk for hepatitis C infection after percutaneous exposure to infected blood is approximately 1.8%. Infection with hepatitis C following mucous membrane exposure has not been quantified but is thought to be rare.

Post-exposure prophylaxis (PEP) is treatment to reduce the likelihood of HIV, HBV and tetanus infection in HCWs after possible occupational exposure. There is no PEP available for HCV.

3.9.6 Annual review of personal protection equipment guidelines

Due to the rapidly evolving nature of all aspects of HIV/AIDS and other bloodborne pathogens (e.g. diagnosis, treatment and care), these guidelines should be reviewed annually by the HIV/AIDS clinical team in the healthcare facility.



3.9.7 HIV personal protection equipment

If there is a significant risk of transmission of HIV, PEP should be initiated immediately without waiting for the results of HIV testing of the exposure source. PEP for HIV should be provided using a combination of two ARV drugs as soon as possible after exposure to a source person with confirmed HIV (or it is medically likely that the source person is infected with HIV). When the injury involves an increased risk of infection — such as with an injury caused by a large-bore needle, associated with a deep puncture, or caused by a device visibly contaminated with blood or a device in a patient’s artery or vein — the regimen should be expanded to include a third drug.

Tables 3.2 and 3.3 summarise current indications³ for PEP.

Table 3.2: Indications for prophylaxis against HIV infection after percutaneous injury or mucosal exposure, according to infection status of the source person

Risk posed by exposure†	Infection Status of Source Person‡				
	HIV-Positive, Class 1	HIV-Positive, Class 2	Unknown status	Unknown Source Person	HIV-Negative
Lower	Basic 2- drug prophylaxis recommended	Expanded (3-drug) prophylaxis recommended	Generally, prophylaxis not warranted, but basic 2-drug prophylaxis can be considered if source person has risk factors for infection§	Generally, prophylaxis not warranted, but basic 2-drug prophylaxis can be considered in settings where exposure to HIV- infected persons is likely	Prophylaxis not warranted
Higher	Expanded (3-drug) prophylaxis recommended	Expanded (3-drug) prophylaxis recommended	Generally, prophylaxis not warranted, but basic 2-drug prophylaxis can be considered if source person has risk factors for infection§	Generally, prophylaxis not warranted, but basic 2-drug prophylaxis can be considered in settings where exposure to HIV- infected persons is likely	Prophylaxis not warranted

† Injuries caused by solid needles and superficial injuries pose a lower risk of infection; those involving a large-bore hollow needle, a deep puncture, a device visibly contaminated with blood, or a needle used in a patient’s artery or vein pose a higher risk of infection. PEP with ARV drugs is **not** indicated for contact between **intact skin** and blood or other body fluids contaminated by HIV.

‡ Class 1 HIV positive status is defined by asymptomatic HIV infection or, if the patient is being managed overseas, a low viral load (e.g. <30,000 copies per ml); Class 2 HIV positive status is defined by symptomatic HIV infection, WHO Stage IV disease (i.e. AIDS), acute seroconversion illness, or a high viral load.

§ If the “source” person has risk factors for HIV infection, prophylaxis is optional and should be based on an individualized decision made jointly by the exposed HCW and the treating doctor.

The Pacific Islands Regional Global Fund Project has made the following ARVs available for PEP in healthcare settings.

Zidovudine (ZDV) — 2 x 60-tablet packs of 300 mg tablets

Lamivudine (3TC) — 2 x 60-tablet packs of 150 mg tablets

Efavirenz (EFZ) — 1 x 30-tablet pack of 600 mg tablets (or 3 x 30-tablet packs of 200 mg tablets)

Nelfinavir (NFV) — 1 x 270-tablet pack of 250 mg tablets.

Following occupational exposure in a HCW that meets the criteria in Table 3.2, ARVs for PEP may be provided according to the regimens prescribed in Table 3.3.

3. United States Public Health Service (available at <http://www.cdc.gov/mmwr/preview/mmwrhtml/rr5011a1.htm>)

Table 3.3 Basic and expanded regimens of antiretroviral drugs for post-exposure prophylaxis against HIV infection

Regimen [†]	Doses	Principal adverse effects
Basic PEP (for lower risk exposure)		
Zidovudine	(ZDV) 1 x 300 mg tablet twice daily for four weeks	Anaemia, neutropenia, nausea, headache, insomnia, muscle pain, weakness
<i>plus</i>		
Lamivudine	(3TC) 1 x 150 mg tablet twice daily for four weeks	Abdominal pain, nausea, diarrhoea, rash, pancreatitis)
Expanded PEP (for NON-PREGNANT individual; higher risk exposure)		
Basic two-drug regimen <i>plus</i>		
Efavirenz (EFZ)	1 x 600 mg tablet (or 3 x 200 mg tablets) at bed time for four weeks	Rash (including Stevens-Johnson syndrome), insomnia, somnolence, dizziness, trouble concentrating, abnormal dreaming; potentially teratogenic in 1 st trimester of pregnancy
Expanded PEP (for PREGNANT individual; higher risk exposure)		
Basic two-drug regimen <i>plus</i>		
Lopinavir/Ritonavir	400 mg/100 mg twice daily for four weeks	Diarrhoea, nausea, abdominal pain, weakness, rash

[†] Nevirapine (NVP) should not be used for PEP due to concerns about short- and medium-term skin and liver toxicity in immunocompetent individuals (i.e. those with normal CD4 cell counts).

PEP should be started as soon as possible after the injury or exposure: no later than 72 hours after exposure and, if possible, within 4 hours of exposure. In general, it is not recommended to start PEP when the exposure occurred more than 72 hours ago (except for exposures that carry a very high risk of transmission).

Routine use of three drugs is not recommended for all exposed individuals because adding a third drug increases the probability that adverse effects will occur, and will further complicate ARV adherence (i.e. that the full four-week course of PEP will not be completed).

If prophylaxis is commenced and the source person is subsequently determined to be HIV negative, ARVs should be discontinued.

3.9.8 Hepatitis B virus personal protection equipment

Childhood vaccination against hepatitis B is included in the expanded programme on immunisation. Management of possible exposure to hepatitis B should follow existing national guidelines and protocols but ideally, all HCWs should already be immune to hepatitis B. Hepatitis B immunoglobulin (HBIG) is available, and vaccination should be given to exposed individuals who have not been previously vaccinated Table 3.4 and Annex II summarise the recommended actions to protect HCWs against occupationally acquired hepatitis B.

3.9.9 Tetanus personal protection equipment

Tetanus prophylaxis should be recommended depending on the type of exposure and the exposed person's past history of tetanus immunisation.

- If less than five years since immunisation, then no tetanus immunoglobulin or tetanus toxoid is necessary.
- If 5–10 years since immunisation, a tetanus toxoid booster is recommended.
- If more than 10 years since immunisation, both tetanus immunoglobulin and tetanus toxoid is recommended.

3.9.10 Hepatitis C virus personal protection equipment

There is no HCV prophylaxis to offer HCWs at this time. Immunoglobulin is ineffective for HCV. For hepatitis C, PEP agents (e.g. ribavirin, interferon) are not currently covered by the Global Fund Project as they are expensive and potentially very toxic. Prevention remains the best way to avoid hepatitis C.

3.9.11 Obtaining advice or additional supplies

If exposure to drug-resistant HIV may have occurred (e.g. if the source patient is on second-line ARVs) or if there are concerns about other aspects of PEP, an expert should be consulted. In such cases, the PEP regimen will be decided on the basis of drugs taken previously by the source patient, their known or possible resistance to different drugs, and the ARVs available in-country at the time.

Initiation of prophylaxis should not be delayed pending such consultation. In the absence of known resistance to ZDV or 3TC in the source patient, the combinations and recommended doses in Table 3.3 should be followed.

Confidential expert advice can be obtained from:

HIV Focal Point, WHO South Pacific Office

Suva, Fiji

Tel +679 330 4600

Email: sengs@sp.wpro.who.int

SPC HIV/STI Section

Noumea, New Caledonia

Tel +687 262 000

Email: denniei@spc.int

Pacific HIV Network (a technical advisory network for HCWs caring for HIV positive individuals in Pacific Island countries)

Email: pacific_HIV@yahoogroups.com

Albion St Centre (International Health Services)

Sydney, Australia

Tel +61 2 9332 9691 or 9332 9692

Regional HIV Pharmacist, Fiji Pharmaceutical Services

Tel +679 338 8000 ext 110;

Email: avosanibola@health.gov.fj

Note: For replenishing ARV stocks for PEP, please notify the project's regional HIV pharmacist as soon as the HCW has been provided with treatment or when current stocks reach two months before their expiry date.

3.9.12 Clinical follow-up and counselling

In addition to HIV antibody testing at the time of the injury, exposed HCWs should also undergo repeat testing at six weeks, three months and six months after exposure.³

If the HCW seroconverts (acquires HIV infection), this will usually occur two to six weeks after exposure, accompanied by a symptomatic acute retroviral syndrome: an acute mononucleosis-like illness with fevers, sweats, malaise, lethargy, anorexia, nausea, myalgia, arthralgia, headache, sore throat, diarrhoea, lymphadenopathy and rash.

HCWs on PEP should practise safer sex (or abstain from sex) until serology is negative at three months post-exposure. Female HCWs who are lactating should consult a specialist regarding cessation of breast feeding while they are taking ARVs.

Occupational exposure to HIV can be a frightening experience and some psychological morbidity (e.g. anxiety, depression, insomnia) and even post-traumatic stress disorder are relatively common among HCWs following such an exposure. Early and frequent follow-up appointments for counselling and clinical review are essential.

Should HCWs become HIV positive, clinical management should follow existing national and regional guidelines⁴ and ongoing counselling and support maintained. International guidelines and recommendations for the management of HIV positive HCWs are also available.⁵

3.9.13 Effectiveness of personal protection equipment in preventing HIV infection following occupational exposure

Factors affecting the likelihood of HIV transmission include the quantity of virus inoculated, the interval between viral inoculation and treatment initiation, treatment duration, and the choice of ARV drugs. Current understanding of the pathogenesis of HIV infection suggests that ARVs should be capable of further reducing the already low rate of infection following occupational exposure provided treatment is initiated early enough.⁶

Clinical trials of ARV use for the prevention of mother-to-child transmission of HIV consistently demonstrate good efficacy following peri-natal exposure, even in neonates who do not receive treatment until after birth. Although these results are encouraging, protection of neonates is not absolute and the relevance of this situation to occupational exposure cannot be guaranteed.

3 If hepatitis C testing is available and if the exposed HCW acquired hepatitis C at the time of the injury, HIV serology should also be repeated at 12 months as hepatitis C virus infection may delay HIV seroconversion.

4 See for example: the National Drugs and Therapeutics Committee. National antiretroviral therapy guidelines, 1st edition. Suva, Fiji: Ministry of Health. 2004.

5 AIDS/TB Committee of the Society for Healthcare Epidemiology of America. Management of healthcare workers infected with hepatitis B virus, hepatitis C virus, human immunodeficiency virus, or other bloodborne pathogens. *Infection Control and Hospital Epidemiology* 1997; 18:349–363.

6 Gerberding JL. Occupational exposure to HIV in healthcare settings. *New England Journal of Medicine* 2003; 348: 826–833.



3.9.14 Special considerations

Where the source person is already on ARVs (especially a second-line or other drug combination), the possibility of HIV drug resistance should be considered. In this situation, seek expert advice through one of the focal points listed in Section 3.9.11 as soon as possible.

Figure 3.1: United States Centers for Disease Control and Prevention algorithm for evaluating the risk of HIV transmission following occupational exposure

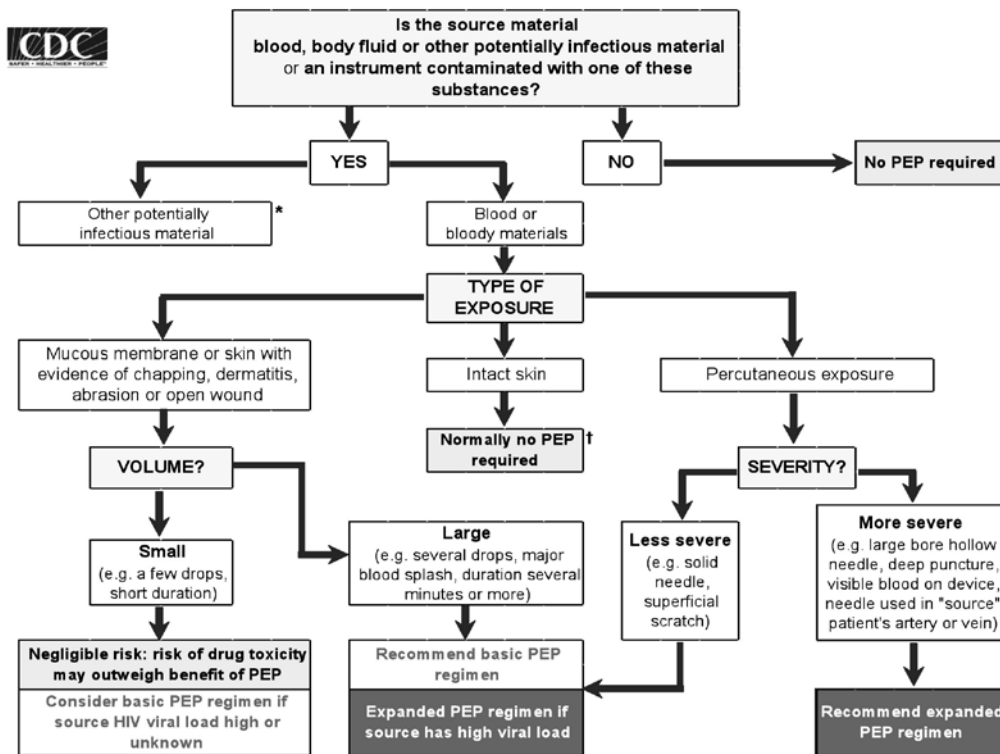

* Other potentially infectious materials include semen; vaginal secretions; cerebrospinal, synovial, pleural, peritoneal, pericardial or amniotic fluid; and tissue. These body substances generally carry a low risk of infection in healthcare settings. Unprotected contact with concentrated HIV requires clinical evaluation to determine the need for PEP.

† Consider PEP if an extensive area was exposed or if prolonged contact with blood occurred.

Table 3.4 Post-exposure prophylaxis against hepatitis B infection where serological testing and hepatitis B immunoglobulin are available

	SOURCE PATIENT	
	HBSAg+	Unknown
Healthcare worker		
Unvaccinated		
	HBIG x 1 dose <i>plus</i> hepatitis B vaccine x 3 doses	hepatitis B vaccine x 3 doses
Vaccinated		
Serological “responder” (anti-HBs \geq 10 mIU/ml)	No treatment	No treatment
Serological “non-responder” (anti-HBs <10 mIU/ml)	HBIG x 1 dose <i>plus</i> hepatitis B vaccine x 3 doses	If higher risk exposure: HBIG x 1 dose <i>plus</i> hepatitis B vaccine x 3 doses
Antibody status unknown	Test for anti-HBs if available If anti-HBs \geq 10 mIU/ml: No treatment If anti-HBs <10 mIU/ml: HBIG x 1 dose <i>plus</i> hepatitis B vaccine x 1 doses	Test for anti-HBs if available If anti-HBs \geq 10 mIU/ml: No treatment If anti-HBs <10 mIU/ml: hepatitis B vaccine x 3 doses

4 Infection Control Practices

Infection control precautions are divided into two distinct groups: standard precautions and additional (transmission based) precautions.

Standard precautions are designed for the care of all patients, regardless of their diagnosis or presumed infection status. These precautions apply to blood, all body fluids, secretions and excretions regardless of whether or not they contain visible blood, non-intact skin and mucous membranes. These general methods of infection prevention are designed to reduce the risk of transmission of micro-organisms from both recognised and unrecognised sources of infection in hospitals. Standard precautions involve safe work practices and include the following:

- hand hygiene
- respiratory hygiene/cough etiquette
- personal protective equipment (PPE)
- appropriate handling of laundry (see Section 8)
- appropriate handling of used patient equipment (see Section 9).

4.1 Hand hygiene

Hand hygiene is the single most important technique to prevent and minimise the spread of infection within hospital environments. Hand hygiene prevents the spread of infection by removing dirt and most micro-organisms carried on the hands of both staff and patients, and includes both hand washing with soap or antimicrobial soap and water, and alcohol-based products (gels, rinses, foams) that do not require the use of water. Alcohol hand rubs may also be prepared by a hospital pharmacy (see Annex 5). It is important to note that when hands are visibly soiled, they must be washed with soap and water; if hands are not visibly soiled, then an alcohol hand rub may be used.

Vigorously scrubbing with soap and water helps to loosen dirt and micro-organisms. Using antiseptics helps to destroy or inhibit micro-organisms on the skin.

Hands should be cleansed after touching blood, body fluids, secretions, excretions and contaminated items, whether or not gloves are worn. Hands should be washed immediately after removing gloves, between patient contacts, and when otherwise indicated to avoid transfer of micro-organisms to other patients or environments.

Washing with plain soap and water or antimicrobial agent, such as an alcohol-based hand rub or waterless antiseptic agent, should be used in the following situations:

- After handling any blood, body fluids, secretions, excretions and contaminated items.
- Between contact with different patients.
- Between tasks and procedures on the same patient to prevent cross-contamination between different body sites.
- Immediately after removing gloves.

A culture of hand hygiene should be encouraged not only among healthcare staff but also in patients and visitors to a facility and the general community at large.

Compliance with hand hygiene is usually sub-optimal. Reasons for poor compliance include:

- lack of appropriate equipment;
- low staff to patient ratios;
- allergies to hand hygiene products;
- insufficient knowledge among staff of risks and procedures;
- time required; and
- casual attitude among staff towards infection control.

There are several types of hand hygiene.

4.1.1 Hand washing

Hands and wrists are washed for 40–60 seconds with soap and water. Hands are dried with a paper towel or, if unavailable, a single-use hand towel. This type of hand hygiene is suitable for all routine procedures.

4.1.2 Hand antiseptics/decontamination

Hand antiseptics remove or destroy transient micro-organisms and confer a prolonged effect. This should be carried out before aseptic procedures. It can be carried out in one of two ways:

- Washing hands and forearms with antimicrobial soap and water, for 40–60 seconds (following manufacturer's instructions). Hands are dried with a hand towel.
- Decontaminating hands with a waterless, alcohol-based hand rub for 20–30 seconds. This is appropriate for hands that are not soiled with protein matter or fat, or otherwise visibly dirty.

Immersing hands in bowls of antiseptics is not recommended.

4.1.3 Surgical hand antiseptics

Surgical hand antiseptics remove or destroy transient micro-organisms and confer a prolonged effect. Hands and forearms are washed thoroughly with an antiseptic soap for a minimum of 3–5 minutes. Hands are dried using a sterile towel. This should be carried out before all invasive procedures.

4.1.4 Hand drying

Hands must be properly dried because micro-organisms transfer more effectively from wet surfaces. Cloth towels are commonly available, but these towels should not be used after they have become damp because they can be a potential source of infection. It is therefore recommended that single-use cloth towels or paper towels be used.

Hand hygiene techniques

Plain soap

Plain soap is used for routine hand washing. Plain soap comes in the form of bar soap, powder and liquid soap.

Antiseptic soap

Antiseptic soaps (antimicrobial soaps) are used for hand washing in "high risk" areas, such as the operating theatre, intensive care unit, labour and delivery unit, nursery or isolation area. Examples of antiseptic soaps include Povidone Iodine surgical scrub (Betadine), which is 60–90% alcohol with glycerine (if applicable).

Alcohol-based hand rub

Alcohol hand rubs are appropriate for rapid hand decontamination between patient contacts, and is recommended when hands are not visibly soiled or contaminated with blood and body fluids. If hands are visibly soiled, then hand washing with soap and water must be done.

Running water

To encourage hand washing, make every effort to provide a continuous supply of fresh water, either from a tap or a bucket. To avoid contamination of bucket water, hands should never be placed directly in the water bucket (rather, water from the bucket should be poured onto hands).

Clean dry towel

Always use a clean, dry towel for drying hands. Individual or paper towels are best. Wet and dirty towels can spread germs. Disposable towels, reusable single-use towels, or roller towels which are suitably maintained should be available. If there is no clean, dry towel, it is best to air dry your hands by simply waving them in the air. Do not dry your hands on your clothing.

Hand hygiene facilities should be located in areas where they can be used easily and frequently.

Hand hygiene techniques (WHO 2005)

1. When using an alcohol-based hand rub, apply about 3 ml (about the size of a dime) of the product to the palm of one hand and rub hands together covering all surfaces of the hands and fingers until hands are dry (about 20–30 seconds; if hands are dry in 10–15 seconds, not enough hand rub was used). When washing hands with soap and water, wet hands with water and apply the amount of product necessary to cover all surfaces. Vigorously perform rotational hand rubbing on both palms and interlace fingers to cover all surfaces. Pay particular attention to the fingernails and nail beds. Rinse hands with water and dry thoroughly with a single-use towel.
2. Use clean running water whenever possible.
3. Use towel to turn off faucet.
4. Make sure hands are dry. Use a method that does not re-contaminate hands. Make sure towels are not used multiple times or by different people.
5. Avoid using hot water, as repeated exposure to hot water may increase the risk of dermatitis.
6. Liquid, bar, leaflet or powdered forms of plain soap are acceptable when washing hands with a non-antimicrobial soap and water. When bar soap is used, small bars of soap in racks that facilitate drainage should be used.

Figure 4.1: Steps for hand washing



Source: SPC 2008

4.2 Respiratory hygiene and cough etiquette

Respiratory hygiene and cough etiquette procedures should be used by all patients with respiratory symptoms (e.g. coughing, sneezing).

People with respiratory infections should be educated to:

- cover their mouth and nose with a tissue when coughing, and dispose of used tissue in waste and/or garbage containers. If no tissues are available, cough or sneeze into the hands then wash immediately;
- spit into tissue if spitting is necessary and dispose of tissue into waste and/or garbage bin;
- perform hand hygiene (use an alcohol-based hand rub or wash hands with soap and water) each time after contact with respiratory secretions;
- wear a mask (if available) if you are coughing in order to protect other people in the waiting area.

Healthcare facilities should promote respiratory hygiene and cough etiquette by:

- ensuring that appropriate materials are available for patients to adhere to respiratory hygiene and cough etiquette;
- promoting the use of disposable tissues (if available) as opposed to using handkerchiefs;
- making masks available in waiting areas to reduce the risk of infection transmission;
- making hand hygiene (e.g. dispensers of alcohol-based hand rubs) with instructions on how to use it available in waiting areas during an influenza outbreak;
- educating patients, family members, and visitors on the importance of covering their mouths and noses with a tissue to help prevent the transmission of influenza and other respiratory viruses;
- making appropriate garbage bins (pedal operated) or open bins available in waiting areas for disposal of used tissues;
- posting signs requesting that patients and family members with acute febrile respiratory illness use respiratory hygiene and cough etiquette;
- ensuring that all staff have access to and are trained in using PPE.

4.3 Personal protective equipment

PPE is an important component in the prevention and control of infectious diseases. PPE also reduces the risk of occupational exposure to a variety of infections, such as avian influenza and SARS. Depending on circumstances, PPE can range from a simple mask to complete body coverage. PPE cannot be used on its own and must be used simultaneously with standard and additional precautions. It is important to use PPE effectively, correctly and at all times where contact with blood, body fluids, excretions and secretions may occur. The use of comprehensive PPE is mandatory if direct, close contact with patients suffering from highly pathogenic airborne viruses such as avian influenza A (H5N1) in humans and SARS is anticipated. When caring for patients with pandemic influenza, HCWs should take extra care to avoid touching their eyes, nose or mouth with contaminated hands (gloved or ungloved). Careful removal of PPE is also very important and healthcare workers should receive training in how to remove PPE. Additional specialised training should be obtained prior to working with these and other highly pathogenic organisms.

PPE may include a combination of the following:

- Gloves
- Eye protection (goggles/shields)
- Mask (surgical, procedure particulate respirators such as NIOSH-certified N95)
- Apron
- Gown
- Boots/shoe covers
- Hair covers

4.3.1 Gloves

Gloves should be worn when touching blood, body fluids, secretions, excretions and contaminated items or surfaces. Clean gloves should be used before touching mucous membranes and non-intact skin. Gloves should be removed after use, before touching non-contaminated items and environmental surfaces, and before tending to another patient or when performing separate procedures on the same patient. Gloves must be changed as soon as they are torn or punctured. Hands should be washed after removing gloves. Using gloves does not eliminate the need for hand hygiene.

4.3.2 Masks, eye protection and face shields

Masks, eye protection and face shields should be worn to protect mucous membranes of the eyes, nose and mouth during procedures and patient care activities likely to generate splashes or sprays of blood, body fluids, secretions or excretions. It is also important to select the right type of mask because surgical or procedural masks (designed to protect against large droplets) differ significantly from particulate masks, which are designed specifically to protect the wearer from exposure to airborne (small particle) infectious diseases such as TB by sealing tightly to the face and filtering infectious particles from the air. Surgical or procedural masks do not provide protection against small particle aerosols. At the same time, N95-type respirator masks are unnecessary and should not be used for activities that do not involve exposure to airborne infectious diseases (e.g. routine surgery, cleaning).

4.3.3 Fluid resistant gowns, aprons, shoe covers and hair covers

Fluid resistant gowns, aprons, shoe covers and hair covers protect skin and hair, and prevent contamination of clothing during procedures and patient care activities likely to generate splashes or sprays of blood, body fluids, secretions or excretions. Clean, non-sterile long-sleeved gowns should be used (fluid resistant, if available). If cloth gowns are used, a waterproof apron should be used if splashing of blood, body fluids, excretions or secretions is anticipated.

Figure 4.2 Sequence for putting on personal protective equipment

Sequence for putting on personal protective equipment (PPE)

Before procedure perform hand hygiene using soap and water or alcohol hand rub

1. Gown

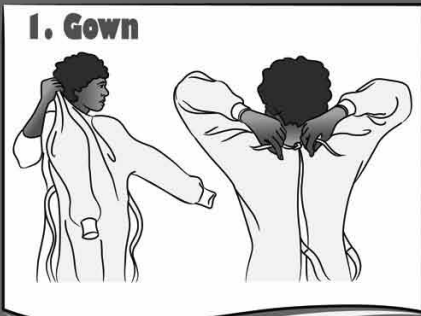

- Long sleeves down to wrist
- Length of gown down to knees
- Ties at back of neck and waist

2. Mask or respirator



- Place mask over nose and mouth and below chin
- Tie strings
- Pull elastic bands over head – upper band above ear line, lower band below ear line
- Fit-check respirator by moulding nose strip over bridge of nose to get a snug fit

3. Goggles or eyeshield



- Put on goggles or eyeshield

4. Gloves



- Put gloves on
- Pull over wrist of isolation gown

Safety precautions

- Avoid adjusting PPE once you enter isolation area
- Avoid touching your face
- Minimise contact with environmental surfaces

Adapted with permission from the CDC's Sequence for Donning Personal Protective Equipment (PPE). <http://www.cdc.gov/>

SPC
Secretariat
of the Pacific
Community
Contact: SPC's Public Health Surveillance
& Communicable Disease Control Section,
Public Health Programme -
Email: phs.cdc@spc.int

With financial assistance from
Australian Government
nzaid

© Illustration: JPR Le Sun

Source: SPC 2008

Figure 4.3 Sequence for removing personal protective equipment

Sequence for removing personal protective equipment (PPE)

- 1 Remove PPE at doorway or in anteroom.
- 2 Remove respirator mask after leaving isolation room and closing door.

1. Gloves



- Grasp outside of first glove with opposite gloved hand and peel off
- Hold removed glove in gloved hand
- With ungloved hand slide finger just under wrist of gloved hand
- Roll off over first glove
- Discard in waste bin

2. Goggles or eyeshield

(front of goggles/eyeshield is contaminated!)

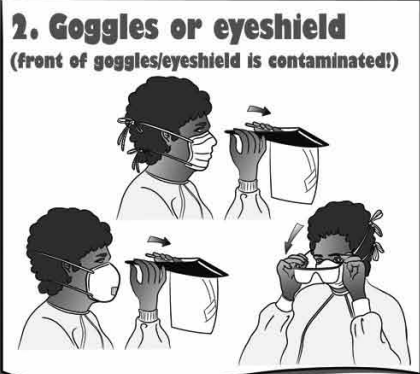

- Do not touch front of goggles or eyeshield
- Hold earpieces of goggles or headband of eyeshield and remove
- Place in container for cleaning and disinfection

3. Gown

(front of gown is contaminated!)



- Do not touch outside of gown
- Undo ties at neck and waist
- Roll off from neck and shoulders, turning gown inside out
- Discard in waste bin

4. Mask or respirator

(front of mask/respirator is contaminated!)



- Do not touch front of mask or respirator
- For respirator mask: grasp top tape and then bottom tape with your hands
- Lift carefully over head and remove
- For surgical mask: untie straps and lift away from face
- Discard in waste bin
- Perform hand hygiene immediately with soap and water or alcohol hand rub



SPC
Secretariat
of the Pacific
Community

Contact: SPC's Public Health Surveillance
& Communicable Disease Control Section,
Public Health Programme -
Email: phs.cdc@spc.int

With financial assistance from



Australian Government
nzaid

Adapted with permission from the CDC's Sequence for Donning Personal Protective Equipment (PPE). <http://www.cdc.gov/>

Source: SPC 2008

4.4 Additional (transmission-based) precautions

Additional or transmission-based precautions are designed for use on patients who are diagnosed with, or suspected to have, a specific infectious pathogen whose transmission cannot be prevented through standard precautions alone. There are three types of transmission-based precautions: airborne precautions, droplet precautions, and contact precautions.

These precautions may be used separately from each other or in combination, depending on the disease involved. Whether used singularly or in combination they are always used in addition to standard precautions. Table 4.1 provides a list of diseases that require these additional precautions.

4.4.1 Airborne precautions

Particles containing the infectious agent are disseminated in the air. Micro-organisms carried this way can be widely dispersed via air currents and can remain infectious in the environment for long periods before being inhaled by or deposited onto the susceptible host. Patients requiring airborne precautions should be placed in a negative pressure isolation room (e.g. infectious TB patients should not be housed on general medical wards).

The following airborne precautions should be implemented:

- Standard precautions.
- Patients should be placed in a negative pressure room with doors closed. If a negative pressure room is unavailable, then place them in a single room (doors closed) with open windows for natural ventilation, and use a fan (blowing outward) to control the direction of air flow.
- Particulate masks (N95) should be worn by HCWs and visitors upon entry into the room.
- Patients should be moved as little as possible out of the room, but if movement is necessary, the patient should wear an N95 mask to minimise dispersion of airborne nuclei.
- A sign should be placed on the patient's door explaining the necessary precautions.

4.4.2 Droplet precautions

Droplets are large liquid particles that are generated during coughing, sneezing, talking, and during the performance of certain clinical procedures such as suctioning and bronchoscopy. Transmission occurs when droplets containing micro-organisms come in contact with the conjunctivae of the eye, nasal mucosa, or mouth of a susceptible person. Droplets distribution is limited by the force of expulsion and gravity (not air movement), usually one metre or less.

The following precautions should be implemented:

- Standard precautions
- Patients should be kept in a single room with the closed door.
- Surgical masks (not N95) should be worn by healthcare workers and visitors upon entry into the room.
- If the patient is transported out of the room, then they should wear a surgical mask.
- A sign should be placed on the patient's door explaining the necessary precautions.

4.4.3 Contact precautions

Diseases that require contact precautions include enteric infections, skin infections and colonisation, and infections from antimicrobial resistant micro-organisms. The most important and frequent means of infection transmission can be divided into two subgroups: direct contact transmission and indirect contact transmission.

- **Direct contact** transmission involves direct physical transfer of micro-organisms from an infected or colonised person to a susceptible host.
- **Indirect contact** transmission involves a susceptible person coming in contact with a contaminated (usually inanimate) object, such as a contaminated instrument or equipment.

The following precautions should be implemented:

- Standard precautions.
- The patient should be kept in a single room with the closed door or with another patient infected with the same pathogen.
- The HCW must wear a clean, non-sterile disposable gown and clean non-sterile gloves when they are in contact with the patient, environmental surfaces and patient care items and equipment in the patient's room.
- A sign should be placed on the patient's door explaining the necessary precautions.

4.4.4 Patient placement

Isolating patients who require additional precautions is very important in preventing the transmission of infection.

There should be 1–2 meters space between hospital beds to reduce the risk of cross infection. If single rooms are not available, patients with the same pathogen should be kept together in either a room or a ward. The room or ward should be in a well-defined area that is clearly separated from other patient care areas used for uninfected patients.

4.4.5 Preparation of the isolation room/ward (see also Annex 7)

- A sign should be placed on the patient's door explaining the necessary precautions.
- Remove unnecessary furniture and keep only the necessary furniture that can be easily cleaned.
- Stock linen.
- Stock hand hygiene products (e.g. liquid soap, alcohol-based products, paper towels)
- PPE should be available.
- Sharps container should be placed inside the isolation room.
- Garbage bags and bins should be placed in the isolation room.
- Trolley to hold PPE.
- Container for collection of used eye shields to be decontaminated.
- Recording sheet should be placed at the entrance of the isolation room so that staff can record the names and contacts of visitors that enter the isolation room so that contact tracing is possible if necessary.

Table 4.1: Recommended infection control precaution guideline

Isolation Type	Standard precautions	Airborne precautions	Droplet precautions	Contact precautions
Diseases (examples)	All patients All blood, body fluids, secretions (except sweat), excretions and contaminated items	<ul style="list-style-type: none"> • TB suspect/confirmed • measles • varicella (chickenpox) • SARS • MDR TB • influenza (when performing procedures that are aerosol generating) 	<i>Haemophilus influenzae</i> meningitis/epiglottitis <i>Neisseria meningitidis</i> septicaemia/meningitis diphtheria (pharyngeal) mycoplasma (pneumonia) pertussis influenza parainfluenza mumps parvovirus B19 rubella pneumonic plague Group A streptococcal infections in infants and young Group A Streptococcal pneumonia, scarlet fever in all groups <ul style="list-style-type: none"> • viral haemorrhagic fever (e.g. Ebola) 	<ul style="list-style-type: none"> • Resistant bacteria (MRSA, VRE, <i>C.difficile</i>, RSV) • Herpes simplex (neonatal or mucocutaneous) • Highly contagious skin infections (e.g. scabies, lice, impetigo) • Herpes zoster (shingles), localised and disseminated • Infants/young children (<6 years old), or any patient inconsistent with: <ul style="list-style-type: none"> - Enterovirus - Hepatitis A - Rotaviral enteritis; - shigella, giardia, other forms of gastroenteritis. • Viral haemorrhagic fever (e.g. Ebola) • Influenza
Single room	No	Yes-keep door closed; If unavailable, may cohort with patients with same organism	Yes-keep door closed If unavailable, may cohort with patients with same organism	Use if possible, or cohort with patient with similar condition
Negative pressure room	No	Yes	No	No
Hand hygiene	Yes	Yes	Yes	Yes
Gloves	For body substances	See standard precautions	Yes	Yes
Gown	If soiling likely	See standard precautions	Yes	Yes
Mask	Protect face if splash likely	Yes (particulate mask N95)	Yes	See standard precautions
Goggles/face shields	Protect face if splash likely	See standard precautions	See standard precautions	See Standard Precautions
Special handling of equipment	Gloves for handling equipment contaminated with blood and body fluids	See standard precautions	See standard precautions	Single use if possible
Transport of patients	Cover all patient's open wounds	Mask for patient; Notify area receiving Patient	Regular mask for patient; Notify area receiving patient	Notify area receiving patient
Room cleaning	Standard cleaning protocol	May require additional cleaning depending on micro-organism See infection control nurse	May require additional cleaning depending on micro-organism See infection control nurse	May require additional cleaning depending on micro-organism See infection control nurse

5 SAFE HANDLING AND DISPOSAL OF SHARPS

5.1 Introduction

The most common way in which HCWs are at risk to HIV, hepatitis C and hepatitis B viruses at the workplace is through accidental injury with sharp objects. The potential for transmission of bloodborne diseases is greatest when needles and other sharp instruments or devices are used. Special care should be taken to prevent injuries when cleaning reusable sharp instruments and disposing of sharps.

5.2 Responsibility for sharps

All HCWs who use sharps are responsible for their safe disposal into “sharps containers”.

Safe practices when handling sharps include the following.

- Sharps should not be passed by hand between a health care worker and any other person; a puncture resistant tray or kidney dish must be used to transfer sharps.
- Needles should never be recapped.
- Do not bend needles, lancets or other sharp after use.
- Sharps should never be forced into a sharps container.

5.3 Sharps containers

Official sharps containers should be ordered well in advance of their anticipated need to prevent shortages. If absolutely necessary, a puncture-proof container can be made from thick plastic, cardboard or metal. Use locally available items such as a heavy plastic bottle or a milk tin if there are no special sharps containers available.

- Dispose of all sharp objects in puncture-proof containers.
- Sharps containers must be puncture resistant and must be labelled “sharps”.
- The container should have an opening that is wide enough to allow the sharps to be dropped into it.
- The container should never be overfilled and should be replaced when it is three-quarters full. When it is three-quarters full, close the lid or cover with tape.
- Sharps containers should be placed as close as practical to the point of use. For example, containers should be placed on the medicine trolley, and in the treatment or immunisation room.
- Sharps containers should not be placed in a place where they are easily accessible to children.
- Sharps containers should be incinerated and then buried. They should not be disposed of in a regular municipal waste facility.

5.4 Needle stick injuries

Needle stick injuries should be reported in accordance with the healthcare facility’s policy on “Management of Occupational Exposures” (see Section 3.9).



6 ENVIRONMENTAL MANAGEMENT PRACTICES

6.1 Introduction

A clean environment plays an important role in the prevention of a healthcare associated infection. Many factors can significantly influence the transmission of a healthcare associated infection, including the design of patient care areas, operating rooms, water supply, cleaning, disinfection and sterilisation, healthcare waste management, food safety and laundry services.

6.2 Water

Each healthcare facility must have a safe, adequate water supply that is free of physical and microbiologic pollution, free from toxic substances, and clear, colourless, odourless and drinkable.

There should be enough water for:

- drinking, bathing and washing patients;
- operating excreta disposal systems;
- washing hands and equipment after contact with patients; and
- other cleaning activities to maintain a healthy environment.

6.3 Ensuring a safe and adequate water supply

The quality and safety of the water supply in healthcare facilities should be checked to ensure it is 1) protected as much as possible from contamination; 2) stored in a clean manner, free from contamination; and 3) in sufficient quantity for meeting the healthcare facility's needs.

If the water supply is likely to be contaminated, then the water must be disinfected and/or the water source must be better protected. It is cheaper and easier to protect the water source. Disinfection of water sources by healthcare facilities is normally only carried out in emergencies caused by sudden outbreaks of waterborne diseases. When outbreaks of waterborne diseases do occur, the water supply source should be checked and chemically disinfected until the cause of the contamination has been removed. Boiling water for at least 10 minutes is an alternative way of making water safe for drinking.

In some areas, rainwater catchment systems and wells that are well protected from sources of pollution can provide an adequate supply of safe water without any need for further treatment.

6.4 Water disinfection

In emergencies caused by outbreaks of waterborne diseases, the necessary equipment and procedures for disinfecting small quantities of water by chlorination are as follows.

- Plastic bucket for mixing solution.
- Plastic containers, with cover, for storage of solution.
- Large plastic closed bucket with a tap or a pot.

- Tablespoon or measuring cup for measuring.
- Large stick for mixing.

Procedures for disinfecting water are as follows.

1. Prepare a stock solution of 1% concentration according to the table below.
2. Mix and wait for 30 minutes.
3. Pour the clear chlorine stock solution into another container for storage and use.
4. Always keep the stock solution in a cool, dark place.
5. To disinfect water that is clear and has a light colour, add 3 drops of the stock solution to each litre of water. If the water to be disinfected is clear, but is like the colour of tea, add 6 drops of the stock solution to each litre of water. If the water is cloudy, it must be filtered before chlorine can be effective.
6. After adding the chlorine solution to the water, mix the water thoroughly and wait for 30 minutes before using the water.
7. Use clean containers that have a tap for storing disinfected water. Wash the containers once a week, or more often if they get dirty. Wash the containers using boiled water, or water that has 6 drops of chlorine stock solution to each litre of water.

Note: Stock solution must be freshly prepared each time it is used. Stock solution that is left standing will quickly lose its disinfecting ability.

Table 6.1: Ingredients for making a stock solution of chlorine (1% concentration by weight of available chlorine)

Product (Per cent concentration by weight of available chlorine)		Amount (Add to 1 litre of water)
Calcium hypochlorite (70%) or		15 g
Bleaching powder or chlorinated lime	(30%) or	33 g
Sodium hypochlorite (liquid bleach)	(3.5%)	357 ml
	(4.0%)	313 ml
	(5.0%)	250 ml
	Clorox (6.0%)	210 ml

6.5 Collecting rainwater using a roof catchment system

Water collected from roofs should be clean and free of debris.

Equipment used to catch rainwater from roofs includes:

- Water tank with outlet tap
- Guttering
- Spouting
- Wire mesh screens

Procedures for collecting rainwater are as follows.

1. Only collect rainwater from roofs made of tiles, slates, galvanised iron or aluminium sheeting.

2. Make sure roof gutters slope towards the “downspout” to prevent pools of water forming where mosquitoes can breed.
3. Clean the roof and gutters regularly to remove dust, leaves and bird droppings. This will ensure that the collected water is safe to drink and does not pool in the gutter where mosquitoes can breed. Keep tree branches away from the roof to prevent leaves from collecting on the roof.
4. Arrange the downspout so that the first water from each rainfall does not run directly into the tank. This ensures that any debris from the roof does not end up in the tank. The downspout can be moved again to collect water after the first, dirty water has passed through. This will need to be done if it does not rain regularly in the area.
5. Put a wire mesh screen over the top of the downspout and the tank overflow to prevent debris from collecting.

Figure 6.1: Collecting water with a roof catchment system

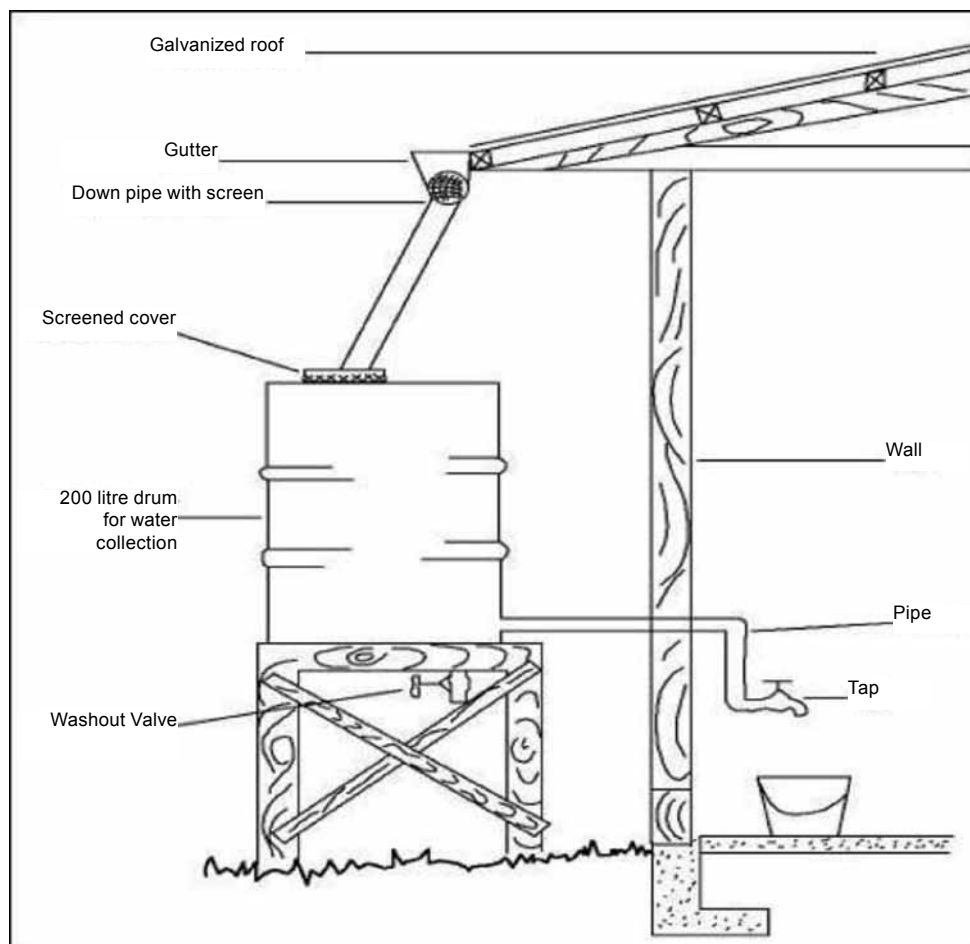

Source: Adapted from the Fiji Ministry of Health 2002, Infection control manual for health facilities.

6.6 Providing protection to wells used for drinking water

The equipment needed to protect well water includes:

- Handpump suitable for the well depth
- Cement and reinforcement
- Tools for concrete construction and handpump installation
- Wire fence to protect from animals.

Procedures for protecting well water are as follows.

1. Select a handpump that is durable, easily maintained and suitable for local conditions.
2. Then mortar the upper two liner joint to prevent contamination from the surface entering the well.
3. Use concrete well liner rings to construct the well.
4. Construct a concrete cover and apron on the top of the well; this will also prevent contamination entering from above.
5. The apron cover should also provide drainage of water away from the well.
6. Install the pump on the well.
7. Be sure to organise a maintenance procedure including a stock of spare parts that may be required.

Drainage systems include pipe drains, open drains (lined or unlined), subsoil drains, vertical drains or soakholes. It is important to have drainage systems to remove unwanted surface water by gravity, so that insects can not breed there. Soakholes and soakpits are ground holes that are filled with stones and should be around public taps and handpumps. Unwanted water in the facility grounds can be removed by filling the hollows in the ground and building a piped or open ditch drainage system.

Note: Surface water is dangerous. Get rid of unwanted surface water so that mosquitoes cannot breed in it. Diesel and benzene fuel pumps are now available and should be used wherever possible to eliminate standing surface water.

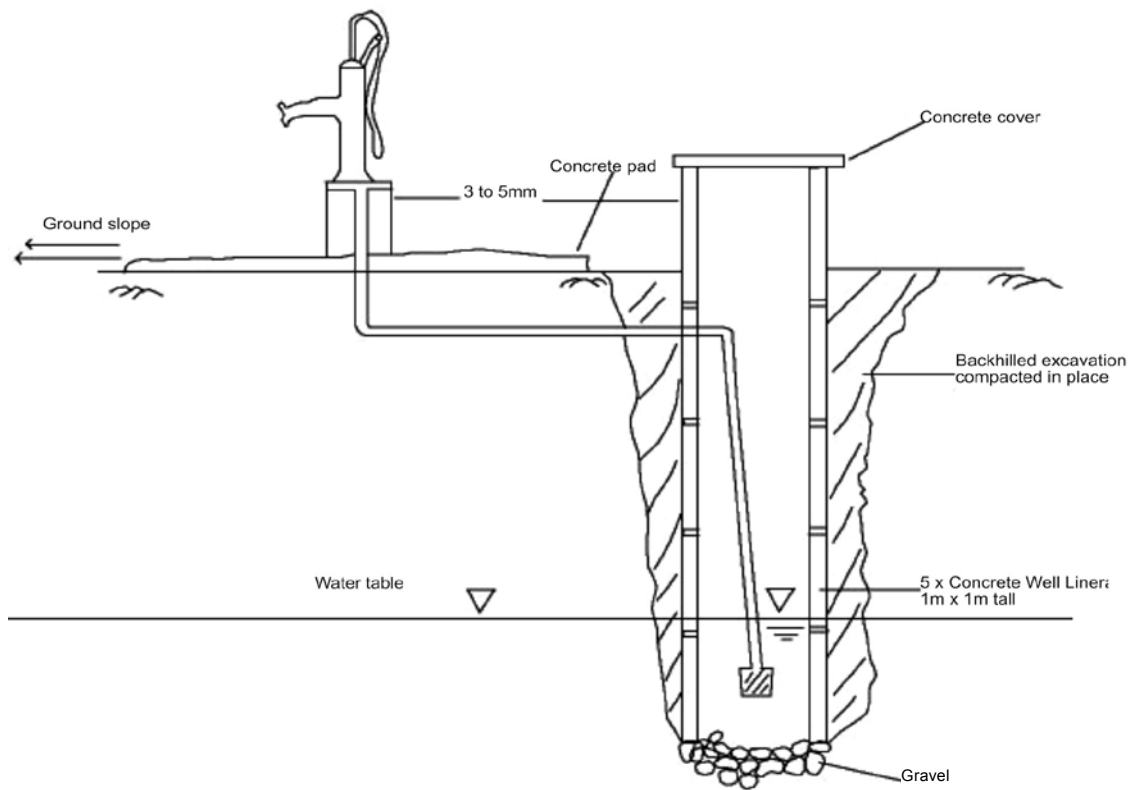
Figure 6.2: Handpump

Source: Adapted from the Fiji Ministry of Health 2002, Infection control manual for health facilities.

7 CLEANING THE HEALTHCARE ENVIRONMENT

7.1 Introduction

Housekeeping refers to the general cleaning of the healthcare environment. Proper housekeeping procedures in hospitals and community health services are important because cleaning reduces the number of micro-organisms, and enhances the well-being of patients and staff. Cleaners have the responsibility of helping to keep the environment clean and safe, not just for patients but for their colleagues as well; cleaners are an integral part of the healthcare system. Personal hygiene is also important (i.e. clean uniform everyday, hand hygiene, clean hair).

Chemical disinfectants should not be part of routine cleaning procedures. Neutral detergent is the cleaning solution of choice for environmental surfaces.

A cleaning programme is determined by:

- the function and role of the area;
- occupational density;
- traffic;
- nature, type and condition of furnishings, fabric finishes and surfaces;
- infection control requirements;
- age and location of buildings.

The hospital or healthcare facility may be divided into areas, such as patient areas (e.g. wards); clinical areas (e.g. lab, x-ray); and non-clinical areas (e.g. corridors, offices).

7.2 Important housekeeping practices

Important housekeeping practices include the following.

- Scrubbing with soap and water is the most effective way to remove dirt and micro-organisms.
- Always wash hands after cleaning procedures.
- Wear utility gloves to clean contaminated areas such as toilets, spills of blood and body fluids.
- Do not use antiseptics (solutions for the skin) for cleaning equipment and surfaces.
- When using neutral detergent, follow dilution instructions. Too much or too little water may not destroy micro-organisms.
- Write schedules for all housekeeping personnel for more effective housekeeping practices (e.g. “Walls should be cleaned every Tuesday”).
- Use a wet cloth or mop for walls and floors. Dry sweeping and dusting spread dust and micro-organisms into the air and onto patients and clean surfaces.
- Use separate equipment (e.g. cloth, brushes, buckets) for cleaning. Use separate equipment (e.g. cloth, brushes, buckets) for cleaning contaminated areas such as toilets.
- Change solutions when they look dirty.
- Wash cleaning cloths daily and dry them in the sun. Soiled cleaning equipment can spread micro-organisms.



- Always clean from top to bottom, so that soil and dust that falls on the floor will be cleaned-up last.

Note: Avoid soiling clean areas while you are cleaning dirty areas. Do not use disinfectant fogging (fumigation with formalin). Fogging may be toxic (poisonous). Scrubbing with soap and water is a quick, safe and more effective way to remove micro-organisms from rooms and cabinets.

Table 7.1: Example of a routine cleaning schedule

Item	Schedule	Equipment needed
Wash basin	Daily and as needed	soap, water
Bathrooms	Every two hours and as needed	soap, bucket, cloth
Bedside lockers	Daily: damp wipe	soap, water
Beds	Friday: clean thoroughly	bucket, cloth
Buckets, bedpans, urinals, sputum, mugs, feeding cups and basin	After each use	soap, water
Cleaning cloths	Daily	soap, water, bucket
Dustbin	Daily and as needed	soap, water, cloth
Walls: dusting and cobweb removal.	Sunday and as needed	long-handled broom
Walls: wipe with a wet cloth; also include the stands for intravenous sets, oxygen tanks, and bed screens.	Monday and as needed	soap, water, bucket cloth
Fans	Thursday and as needed	damp cloth
Floors	4–5 times daily Morning duty 7 am: wet mopping 11 am: sweeping and wet mopping Afternoon duty 2 pm: sweeping and wet mopping 6 pm: sweeping Night duty 6 pm: sweeping 8 pm: sweeping and wet mopping	broom/dusting soap, water, bucket cloth
Window net	Tuesday and as needed	broom
Window glass	Wednesday and as needed	scraper, cloth, water bucket

Note: Always use a different cloth when cleaning floors, bathrooms, and patient items. Establish schedules for cleaning floors, environmental surfaces, sinks and toilet areas.

7.3 *Cleaning spills of blood and other body fluids*

The purpose of cleaning up spills of blood and other body fluids is to destroy harmful micro-organisms such as HIV, HCV and HBV.

The items needed for cleaning spills include:

- Neutral detergent.
- Cloth or old pieces of linen, paper towel.
- Mop.

The procedures for cleaning spills are:

1. Wear gloves.
2. Wipe up spills with a cloth or paper towel and discard in waste bin.
3. Mop up remainder of the spill using neutral detergent.

7.4 *Proper disposal of loose sharps*

Cleaning staff should not be required to clean up loose sharps. Loose sharps should be notified to the on-duty medical supervisor so that HCWs can dispose of sharps properly. This will also serve to encourage proper disposal of sharps in the first place.

7.5 *Colour coding cleaning equipment*

A standard for colour coding cleaning equipment is the most effective method of restricting equipment to individual areas of health facilities. Equipment may include dry mops, wet mops, mop handles, buckets, wringer buckets, gloves.

Typical colour coding for equipment	
Infectious/isolation areas	yellow
Toilets/bathrooms/dirty utility rooms/sluisce	red
Food service/preparation areas	green
General cleaning	blue
Operating theatres	white

All other equipment that would assist in the control of infection should also be colour coded.

8 HEALTHCARE LAUNDRY MANAGEMENT

8.1 Introduction

The objective of the laundry system is to provide a properly designed laundering programme in a safe and sanitary environment, and ensuring the supply of clean and hygienic laundry. Health service managers and staff share the responsibility for achieving this objective.

Health service managers are responsible for providing:

- an appropriate and safe laundry facility;
- standard procedures and guidelines for handling, using and laundering clean and contaminated linen; and
- training, educating and instructing staff about potential infectious hazards and techniques to prevent the spread of infection

Linen used in healthcare facilities carries many micro-organisms. Used linen that is soiled with blood, urine, faeces or other body substances may be particularly infectious. Processing soiled linen consists of collecting, transporting and sorting the linen before it is washed, followed by storing and distribution.

HCWs are responsible for ensuring that:

- standard precautions apply when handling clean and contaminated linen;
- linen is free of foreign matter such as sharps and instruments before it is sent for laundering;
- soiled and infectious linen is appropriately treated and handled in accordance with the facility's policies and procedures; and
- used linen is not sorted in patient care areas.

8.2 Using personal protective equipment

When collecting, handling, transporting, sorting or washing soiled linen, housekeeping and laundry staff should wear:

- household utility gloves;
- closed shoes that protect feet from sharp items and from blood and body fluid spillages;
- protective eyewear; and
- plastic or rubber aprons.

8.3 Collecting and transporting soiled linen

The following steps should be taken when collecting and transporting soiled linen.

- Place used linen in bags or in linen trolleys with lids. If linen is heavily soiled with blood and/or body fluids, it should be placed in a leak-proof bag or a container with a lid.
- Handle soiled linen as little as possible and avoid shaking linen to prevent the spread of micro-organisms into the environment and to people.

- Linen should not be sorted or washed in patient care areas.
- Transport collected soiled linen in trolley carts with lids or covered carts to the laundry processing area once or twice daily.
- Transport soiled linen and clean linen separately, using separate trolleys labelled accordingly.

8.4 *Sorting soiled linen*

Sorting soiled linen is important because in addition to linen soiled with blood and body fluids, linen from places such as operating theatres, labour wards and other procedural areas sometimes contain sharp instruments and soiled dressings soaked with blood and body fluids. When sorting linen, heavy utility gloves, protective eyewear and plastic aprons should be worn. Any items found during sorting should be disposed of properly.

8.5 *Laundering linen*

The following steps should be taken when laundering soiled linen.

- Separately wash heavily soiled linen from non-soiled linen.
- Use the washing machine's time cycle according to the manufacturer's instructions.
- Water temperatures should be above 71°C (160°F)
- When wash cycle is completed, linen should be checked for cleanliness and rewashed if still stained or dirty.

8.5.1 **Storing, transporting and distributing clean linen**

The following measures should be taken when storing, transporting and distributing clean linen.

- Store clean linen in clean, dry closed storage cupboards.
- Use physical barriers to separate folding and storage room from soiled areas.
- Clean and soiled linen should be transported separately in separate trolleys.
- Clean linen should be covered during transport to avoid contamination.

8.6 *Laundry staff*

Good staff practices help reduce the risk of cross-contamination and prevent injury. Therefore, staff should:

- be adequately trained in standard precautions, including hand washing and the risks involved if undertaking other tasks within the facility (e.g. food preparation, patient care). These activities should never be done in laundry areas;
- be educated and trained (and supervised, if appropriate) in the safe use of equipment and machinery, and in safe work practices, including safe manual handling techniques;
- wear appropriate protective clothing and wear appropriate gloves when sorting laundry;
- not eat or smoke in the laundry area;
- not handle linen if they have exfoliative skin conditions (e.g. conditions where skin flakes off), unhealed wounds or rashes, unless appropriate protective measures are adopted (such as covering wounds with bandages).

9 CLEANING, DISINFECTING AND STERILISING EQUIPMENT AND INSTRUMENTS

9.1 Introduction

Used instruments and equipment can be a reservoir for micro-organisms, and therefore spread infections to patients and staff. Procedures that prevent the spread of infection from reusable instruments and equipment are cleaning, disinfection and sterilisation. Before disinfection and sterilisation can be achieved, however, all instruments must be cleaned and rinsed.

Table 9.1: Instruments and equipment by application and sterilisation method

Category	Application	Type of processing	Example of items
Critical	Sterile tissues in the body	Sterilisation	Surgical instruments, diagnostic catheters, dental instruments, bronchoscopes, cystoscopes
Semi-critical	Non-sterile tissues in the body	Disinfection	Respiratory therapy equipment, dental impressions and other prosthetic appliances, gastroscopes, colonoscopes, endoscopes
Non-critical	Instruments that come in contact with intact skin	Cleaning	Bedpans, ECG leads, thermometers, stethoscopes, beds, bedside tables

After cleaning, all instruments and other items used to touch tissue beneath the skin (such as during surgery or giving an injection) or to touch mucous membranes (such as during vaginal examination) should be sterilised or undergo high-level disinfection (HLD).

Sterilisation is the safest and most effective method for the final processing of instruments. When sterilisation equipment is not available or not suitable, HLD is the only acceptable alternative.

Definitions association with cleaning, disinfection and sterilisation

Cleaning	Physical removal of soil and micro-organisms from the skin and objects with soap and water.
Detergent	A cleaning agent available in two forms: liquid or powder.
Decontamination	Cleaning an object to reduce the number of micro-organisms on it by either chemical or physical means.
Disinfection	A process that kills or destroys most disease producing organisms, but rarely kills spores. Disinfectants are used on inanimate objects as opposed to antiseptics, which are used on living tissue.
Sterilisation	A process that destroys all forms of microbial life, including bacteria, viruses, spores and fungi. This method is used for all items that contact normally sterile areas of the body.

Note: Keep used, dirty items separate from clean and sterile ones to prevent cross contamination.

9.2 Cleaning

9.2.1 Why cleaning is important

The cleaning process is very important because:

- cleaning with neutral detergent and water removes protein, blood and other body fluids, oils and grease;
- disinfection and sterilisation will not destroy micro-organisms trapped in small particles of blood or protein. Thorough cleaning must be done to remove these particles; and
- when sterilisation facilities (steam heat or hot air oven) are not available, cleaning is the only way to protect patients from pathogenic spores.

9.2.2 Choosing a detergent for cleaning instruments and equipment

Using a hospital grade neutral detergent is important for effective cleaning because water alone will not remove protein, oils and grease. Bleach powder without a detergent should not be used. Hand soap should not be used because it is made from fat (lard), and will leave a film or scum on instruments. Micro-organisms can become trapped in the scum, and will not be destroyed during sterilisation or disinfection.

Do not use abrasive cleaners because they can scratch instruments. Scratches are places where micro-organisms can become trapped, and scratches increase metal corrosion (rusting).

9.2.3 Equipment and procedures for cleaning environmental surfaces

Cleaning environmental surfaces helps destroy and remove soils and micro-organisms, making environmental surfaces such as operating tables or delivery tables safe to use for the next patient.



The items needed to properly clean environmental surfaces include:

- Neutral detergent.
- Clean water.
- Plastic bucket.
- Household gloves.

Procedures for cleaning environmental surfaces are as follows.

1. Put on gloves.
2. Using a cloth soaked in neutral detergent, wipe metal and plastic surfaces.
3. Allow surfaces to air-dry.

9.2.4 Routine cleaning of used instruments and equipment

Routine cleaning of instruments and equipment removes many micro-organisms.

The items needed for the routine cleaning of instruments and equipment include:

- Neutral detergent.
- Clean water.
- Brush.
- Gloves (utility gloves are best).

Procedures are as follows.

1. Put on gloves.
2. Completely disassemble all items.
3. Using soapy water and brush, completely remove all blood, tissue and dirt. Carefully clean small spaces and teeth of clamps.
4. Thoroughly rinse with water, because soap can interfere with the disinfection or sterilisation process.
5. Air-dry equipment as moisture can interfere with the sterilisation or disinfection process.
6. Instruments and equipment are now ready for sterilisation or disinfection.

Points to remember when cleaning instruments and equipment

- Thorough cleaning is the most important step when reprocessing instruments and equipment.
- Wear gloves while cleaning instruments and equipment. Thick household or utility gloves are best because they help to prevent injury from sharp objects.
- Completely disassemble any equipment that can be taken apart, before cleaning (e.g. clamps and scissors).
- Use a brush for cleaning. A small brush (e.g. toothbrush) can be used to carefully clean very small areas where micro-organisms may become trapped (e.g. teeth of clamps, screws and joints).

9.3 Disinfection

9.3.1 High-level disinfection

High-level disinfection (HLD) of items that touch mucous membranes (e.g. respiratory equipment), and items that cannot be autoclaved (e.g. laparoscopes) uses glutaraldehyde. When glutaraldehyde is not available, sodium hypochlorite can be used (see Annex 6).

To make sterilisation or HLD effective:

1. Follow instructions carefully.
2. Make sure that heat, steam, boiling water or chemical disinfectant touches all surfaces of the item being processed.
3. When using heat, make sure to use the correct temperature.
4. Carefully time the process. When using heat, begin timing after the correct temperature has been reached.
5. Be sure all items have been thoroughly cleaned and dried.

Note: Sterilisation and HLD will not destroy micro-organisms trapped in small particles or blood. Thorough cleaning must be done to remove these particles.

Figure 9.1: Processing instruments

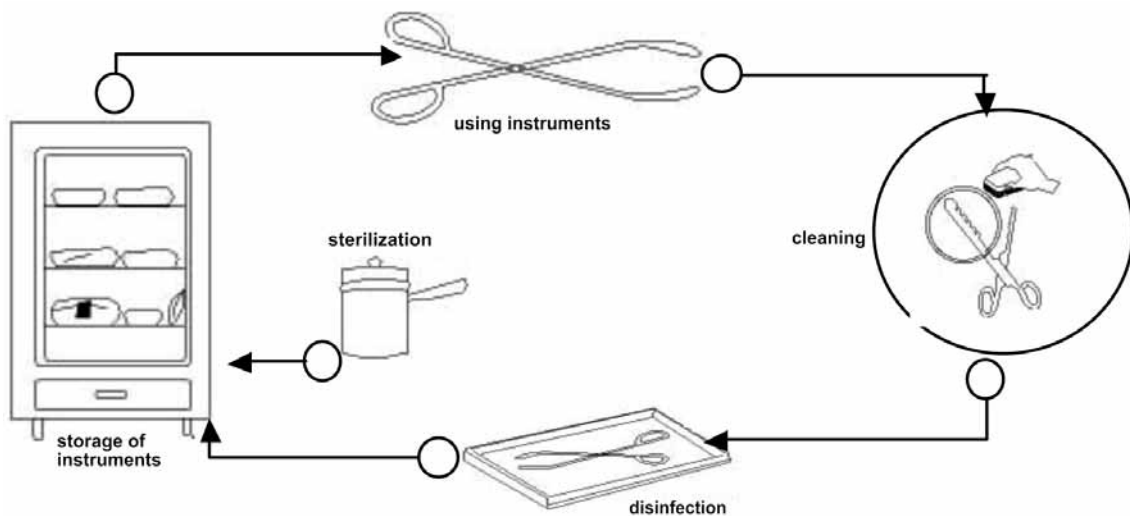

Source: Adapted from the Fiji Ministry of Health 2002, Infection control manual for health facilities.

9.4 Sterilisation

Sterilise instruments and other items that come into contact with the bloodstream or tissue beneath the skin (surgical instruments, wound dressings). Sterilisation is the only process that destroys all forms of micro-organisms, including those that cause tetanus and gangrene. (These spore-forming micro-organisms are very hard to kill.)

9.4.1 Sterilisation methods

The most common sterilisation methods in hospitals and clinics are **steam heat** (autoclave or pressure cooker), **dry heat** (hot air oven), and **gas** (ethylene oxide).

Steam sterilisation (autoclave, pressure cooker) destroys all micro-organisms on objects that are used beneath the skin (e.g. surgical instruments, gloves, needles and syringes), or those that enter sterile areas of the body (e.g. urinary catheters).

The equipment needed to steam sterilise objects include:

- Wrapping material (e.g. cotton cloth, paper).
- Metal instrument trays (with holes in bottom).
- Sterilisation indicator (Table 9.4).
- Autoclave or pressure cooker.
- Heat source (electricity, stove for kerosene).
- Fuel (kerosene, wood).

Procedures for steam sterilisation are as follows.

1. Clean and dry all items to be sterilised.
2. Open and separate all items before processing. For example, open all instruments (forceps, clamps), and wrap tubing around a towel or cloth and coil gently.
3. Wrap items with double thickness cotton muslin cloth or paper.
4. Insert proper sterilisation indicator (e.g. autoclave tape) to show that the article is sterile.
5. Load packs and items in steriliser so that steam can move around packs and penetrate all surfaces.
6. Sterilise items at the correct temperature and pressure and for the correct amount of time (see below). Begin timing after the desired pressure has been reached (on autoclave, check gauge; on pressure cooker, wait for pressure valve to jiggle).
7. Turn off heat source. Wait 30 minutes for steriliser to cool, then slightly open lid to let steam out.
8. Allow packs to dry before you remove them. This takes 20–30 minutes.
9. Remove items from steriliser.
10. Allow them to cool completely before storage, or use immediately.
11. Label the container with the date. Reprocess after expiration.

Table 9.2 Steam sterilisation

Temperature	121° Centigrade (250° Fahrenheit)
Pressure	106 kPa
Time	Unwrapped items: 20 minutes Wrapped items: 30 minutes

Additional notes on steam sterilisation.

- **Wrap packs loosely.** Tightly wrapped packs do not allow steam to touch all surfaces of items and equipment. Where steam does not touch, items will not be sterilised.
- Items that are not wrapped must be used immediately.
- Wait for packs to dry before removing them from the steriliser. Micro-organisms can travel through moisture into the sterile packs.
- When using a pressure cooker, all items must be at least 5 cm above the water.
- When using drums, tilt them and open the lids to allow air to drain out and to be replaced by steam.
- As soon as a drum is opened, all unwrapped items inside become contaminated. Therefore, items should be wrapped even when drums are used.

Table 9.3 Temperature and time for effective dry heat sterilisation

Temperature	Time
170° C (340° F)	60 minutes (1 hour)
160° C (320° F)	120 minutes (2 hours)
150° C (300° F)	150 minutes (2½ hours)
140° C (285° F)	180 minutes (3 hours)
121° C (250° F)	Overnight

Table 9.4: Sterility tests

Methods		Indicators		
Agent	Means	Physical	Chemical	Bacteriological
Dry heat	Flames Hot ovens	Must be red hot Thermometer	None Daily check: heat sensitive dyes	Monthly check: Mix of spore-producing and non-spore producing bacteria
Humid heat (best method for hospitals)	Autoclaves, Pressure cooker (steam under pressure)	Record of: Pressure Temperature Time (duration)	Daily check: heat sensitive dyes for steam saturation	Weekly check: spore test (<i>Bacillus stearothermophilus</i>)
Ethylene oxide	Gas	Is used to sterilise heat sensitive items which cannot withstand temps greater than 60°C	Ethylene gas	Gas indicator.

Note: Sterilisers should be routinely tested to make sure that they are working properly and that instruments and equipment are sterile.

Table 9.5: Disinfectants and their uses on instruments and equipment

Disinfectant	Time	Purpose	Dilution	Comments
Alcohol 70% (SVM)	20 minutes	Kills: Gram-positives Gram-negatives TB HIV Hepatitis B Viruses	None	Does not need to be rinsed off
Chlorine solution (1% available chlorine)	Decontamination 10 minutes Disinfection 20 minutes	Kills: Gram-negatives TB Most spores Hepatitis virus HIV virus	See this Table 6.1	Make a fresh solution every day. Rinse off with distilled water.
Formaldehyde (8%)	20 minutes	Kills: Gram-positives Gram-negatives TB Spores Viruses	1 part formaldehyde + 5 parts water	Prepare fresh solution every 2 weeks. Rinse with distilled water
Glutaraldehyde CIDEX SPORICIDIN	20 minutes	Kills: Gram-positives Gram-negatives TB Spores Viruses	Read manufacturers directions	Use in a well ventilated area. Rinse with distilled water. Expensive. Use only for fiberoptics.

Note: Gram-positive organisms include *Streptococcus*, *Staphylococcus*, and others. Gram-negative organisms include *Escherichia coli*, *Klebsiella*, *Pseudomonas*, and others. Spores include *Clostridium* (gangrene and tetanus) and others. Viruses include measles, mumps, chickenpox, hepatitis and others.

Table 9.6: Length of safe storage for sterile and high-level disinfected items

Wrapping	Safe storage time
Sterile items	
Single wrapped in cloth	1 week
Double-wrapped in cloth	1 month
Paper	1 week
Metal container with cover	1 week
High-level disinfected items	
Dry, high-level disinfected lidded container (unopened)	1 week
SVM or 70% Alcohol	1 week
CIDEX	1 week

10 FOOD SAFETY

10.1 Introduction

The kitchen area plays an important role in the prevention of infection. Cleanliness and safe food preparation and storage practices are critical to:

- preventing outbreaks of food borne illness among patients;
- minimising microbiologic contamination of food by using appropriate food handling techniques during the preparation of food; and
- protecting food from contamination by insects, rodents and moisture.

10.2 Food services hygiene

During food preparation, all kitchen staff should wear appropriate protective clothing such as waterproof or fabric aprons. If fabric aprons are used, the aprons should be changed after each task and before leaving the kitchen area. Staff should also wear clean hats or hairnets that completely cover hair while preparing food. It is advisable for staff to keep an extra clean uniform on hand to change into, in case of excessive perspiration. This may particularly apply to cooking staff.

Some other food service hygiene practices are listed below.

- Wash hands before handling food or utensils and wear plastic gloves when appropriate.
- Wash hands and clean nails after:
 - arriving for work
 - using the toilet
 - handling any foods
 - having contact with unclean equipment and work surfaces, soiled clothing and dishcloths
 - removing gloves
- Coughing and sneezing near food or dishes should be avoided. Where necessary, disposable tissue (rather than a handkerchief) should be used to cover the nose and mouth; hands should be washed immediately after use.
- Hands and fingers should be kept away from hair and face where food contaminant organisms can be picked up and transmitted to food.
- Tongs, forks and spoons should be used when preparing foods to minimise hand contact. Cracked and chipped crockery should be discarded.
- Food should not be tasted with ladle or spoon used in food preparation. Utensils used for tasting should be thoroughly washed between tastes, or disposable utensils used
- Work areas, surfaces and utensils must be cleaned between different preparation tasks
- Plastic gloves are to be worn when direct contact is made with food that is to be consumed without further cooking
- Food service staff must have clean fingernails. Wearing rings and nail polish should be discouraged.

- Employees suffering from infectious diseases should be excluded from duty. (Refer to Section 3.8 on staff work restrictions). If staff with mild respiratory infections are allowed to work, they should wear surgical masks while preparing food.

10.3 *Preparing and serving food*

To prevent contamination of food during preparation and serving, the following are some important points to remember.

- Staff suffering from diarrhoea should be immediately removed from handling food and contact with patients until all symptoms are fully over for 24–48 hours.
- Do not allow staff with infections (sore throat, uncovered skin or wound infections, nausea or vomiting, or diarrhoea) to handle food or equipment.
- Raw food and cooked food should always be prepared separately, using separate equipment.
- Clean up benches and equipment properly before, during and after food preparation
- Wash hands before and after handling any foods.
- All unused food returned to the kitchen after service should be discarded. Do not serve leftovers.
- Disposable gloves should be worn to handle foods that will not receive any further heat treatment (i.e. cooked meats/salad vegetables).

The items and equipment needed for the safe preparation of foods include:

- Soap for hand washing.
- Adequate water supply (hot water is best).
- Adequate supply of equipment for preparing and serving food.
- Smokeless stove or ventilated cooking area.

The following procedures should be followed when preparing and serving food.

1. Wash hands thoroughly with soap and water before preparing and serving food. When available, wear gloves while handling food.
2. Minimise hand contact with food by providing suitable equipment for food preparation and serving.
3. Cut fruits and vegetables on a different surface than from that used for meat preparation.
4. Cook foods on smokeless stove or in a well-ventilated cooking area to prevent smoke inhalation.
5. Serve food as soon as possible after cooking.

10.4 *Preventing contamination*

To prevent contamination of food, the following procedures should be strictly carried out:

- Inspect food on delivery.
- Store food at the correct temperature (see below).
- Separate storage of raw and cooked foods.
- Thoroughly wash hands before handling food, and after cleaning and handling waste.
- Use correct handling techniques during food preparation.
- Promptly serve food at the correct temperature.
- Immediately clean the preparation area, surfaces, machines and utensils after use to remove spills, food particles and moisture (always wipe dry).
- Use correct handling and storage techniques for garbage containers and washing containers after emptying.

10.5 Food storage

Proper food storage prevents contamination from moisture and chemicals, and protects against insects and rodents.

Some important points to remember when storing food include the following:

- Buy meats, milk and vegetables as close to cooking time as possible.
- Do not store these foods overnight, unless refrigeration is available and reliable.
- All perishable food not currently being processed should be stored in a refrigerator at a temperature below 5° C.
- Perishable food is any food that has not been pasteurised or contains moisture.
- All frozen foods should be stored at a temperature of -20° C.
- Store foods in their own respective storage space to avoid cross contamination.
- Raw foods and cooked foods should be kept separate at all times.
- Store raw food below cooked food to prevent drip contamination.
- Cover all food to prevent entry of foreign objects.

The equipment needed to properly store food include:

- Enclosed rooms or cabinets.
- Adequate shelving.
- Leak-proof buckets (plastic or galvanised metal) with lids.

Procedures for storing food:

1. Provide adequate shelf space for all food.
2. Bottom shelf must be 10–12 cm from floor to permit proper floor cleaning under shelves.
3. Build cabinets with doors to keep out rodents and insects.
4. Store flour and other dried foods in plastic buckets or tins, and cover with a tight fitting lid.
5. Do not use insect sprays and/or rodent poisons in food storage areas, because they may poison the food.
6. Maintain secure storage and control over food items.

10.6 Thawing food

Some important points to remember when thawing food items:

- Never thaw foods at room temperature.
- All frozen poultry, red meats and seafood should be thawed by one of two methods:
 - **Slow thaw:** Food is removed from freezer and placed in a refrigerator 24 hours in advance of using
 - **Rapid thaw:** Food is kept under cold water for two hours
- Make sure that all poultry is totally thawed prior to cooking to prevent growth of surviving *Salmonella* and other bacteria.

10.7 Chilling hot food

Some important points to remember when chilling hot foods:

- Foods such as stews and soups that are pre-prepared for consumption at a later time should be rapidly chilled to 5° C to ensure that surviving bacteria do not have the opportunity to multiply. The food can be checked with a thermometer to ensure the required temperature is achieved.
- Divide large quantities into smaller quantities so that the maximum depth of the food in the container does not exceed 10 cm. This enables rapid cooling to ensure that hot food is not placed into the refrigerator.

10.8 Cleaning requirements

The frequency of cleaning food preparation equipment, surfaces and premises will depend on the degree of use in any given period. As a general rule, equipment, utensils and immediate working areas should be cleaned after each use. Premises should be thoroughly cleaned at least daily, with spot cleaning occurring as, and when, required so as to maintain a safe, hygienic environment.

Major cleaning of large equipment (e.g. ovens) should be carried out at least weekly, or more frequently depending on use. Irrespective of any set frequencies laid down, common sense dictates that if an item or surface is soiled, it must be cleaned as soon as possible. Cleaning services in kitchen areas must be able to respond to these situations.

Special emphasis must be placed on hygienic practices and cleaning when there is a change of tasks from raw to cooked food preparation. Meat boards can be clean and disinfected with bleach after use.

10.8.1 Washing cooking and eating utensils

The following equipment is what is needed to properly wash cooking and eating utensils so that micro-organisms are removed.

- Powdered soap (neutral detergent).
- Soap for hand washing.
- Adequate water supply (hot water is best).
- Scouring agent.

Procedures for washing cooking and eating utensils:

1. Wash pots, pans, utensils and trays thoroughly with detergent and water (hot water is best). Use a hard brush to remove difficult particles and stains. Rinse with fresh water.
2. Wash all surfaces used for cutting or slicing food with a scouring agent and water (hot water is best). Use a hard brush to remove difficult particles and stains. Rinse with fresh water.
3. Allow utensils and surfaces to air-dry before storage.

10.8.2 Cleaning the kitchen and food storage areas

Maintaining a clean, sanitary work and storage area is essential.

The following equipment is needed:

- Powdered soap (neutral detergent)
- Soap for hand washing
- Adequate water supply (hot water is best)
- Scouring agent, hand or machine scrubbing device
- Broom, dustpan and brush
- Mop and bucket
- Machine scrubber

Procedures for cleaning kitchen and food storage areas:

1. At the beginning of each day, wipe all surfaces with a clean damp cloth.
2. At the end of each day, clean the kitchen thoroughly with detergent and water (hot water is best).
3. Use separate cleaning equipment for kitchen.
4. Use a broom, dustpan and brush to sweep up all traces of food on the floor. Place in a covered rubbish bin to keep out insects and rodents.
5. Wipe floors with a clean damp mop, detergent and water.
6. Wipe shelves with a clean damp cloth, detergent and water.
7. Wash all cleaning equipment and dry thoroughly to prevent growth of micro-organisms.
8. Remove all waste containers, transport waste to disposal site.
9. Wash waste containers with soap and water.

11 HEALTHCARE WASTE MANAGEMENT

11.1 Introduction

Safe waste disposal helps to:

- prevent the spread of infection to healthcare workers who handle the waste, and to the local community;
- protect those who handle waste from accidental injury;
- prevent open piles of waste that can become breeding ground for flies, other insects and rats, which carry diseases;
- prevent build up of waste, which may pose fire hazards; and
- provide a pleasant atmosphere (uncollected waste causes foul smells, and is unsightly).

The key to effectively managing healthcare waste is segregation (separation) and identification. Segregation is the responsibility of the waste producer, and should take place as close as possible to where the waste is being generated. Healthcare waste should be categorised and placed into colour-coded bags or bins.

Two important points to remember with regards to waste disposal is that 1) open piles of waste are dangerous, and 2) hospital and health centre wastes should be disposed of in an area with a fence around it. All waste should be incinerated or buried.

11.2 Categories of healthcare waste

11.2.1 General waste

General waste includes wastes that do not carry harmful micro-organisms. Examples of general wastes include kitchen refuse, paper waste, boxes, bottles and plastic containers that store products used by the hospital or clinic.

11.2.2 Infectious and/or clinical wastes

Solid and liquid infectious and/or clinical wastes carry harmful micro-organisms and are likely to cause infection among patients, HCWs or people in the community. Infectious wastes may be solid wastes, liquid wastes or laboratory wastes. Examples include used dressings, gauze or other items contaminated with blood, pus, faeces, urine, blood or other body fluids; human tissue; body parts; paper specimen collection cups; pathology samples.

Pathological waste includes human materials removed during surgery, labour or delivery; autopsy; embalming; or biopsy, including body parts and tissues and foetuses; products of spontaneous or induced human abortions, regardless of the period of gestation, including body parts, tissues and foetuses, organs and bulk blood and body fluids. Pathological waste also includes laboratory specimens of blood and tissue after completion of laboratory examination.

Sharps include needles, lancets, hypodermic syringes with attached needles, scalpel blades, razor blades, glass pipettes, broken glassware, intravenous spikes, and any other sharp object with the potential to penetrate intact skin

11.2.3 Pharmaceutical and cytotoxic wastes

Pharmaceutical and cytotoxic wastes include expired, unused, split and contaminated pharmaceutical products, drugs and vaccines that are no longer required and need to be disposed of appropriately. This category of waste also includes discarded items used in the handling of pharmaceutical supplies such as bottles and boxes with residues, gloves and masks, connecting tubing and drug vials.

Cytotoxic drugs are also known as anti-neoplastic drugs or cancer chemotherapy drugs. These are highly hazardous wastes that have mutagenic, estrogenic or carcinogenic properties.

Cytotoxic wastes include:

- Cytotoxic drugs (e.g. azathioprine, chlorambucil, cisplatin, 5-Fluorouracil, cyclophosphamide, melphalan and methotrexate).
- Vomit, urine or feces from patients treated with cytotoxic drugs.
- Contaminated materials from cytotoxic drug preparation and administration such as syringes and needles, dressing packs and gauge vials.

General tips for safe waste disposal

- Use separate marked containers for clinical wastes.
- Use washable waste containers that are strong and will not rust (plastic is best). All waste containers should have lids.
- Do not use waste containers for any other purpose in the hospital or health centre.

11.3 Colour-coding or labelling containers

Colour-code or label containers for the following types of waste:

- **Sharps:** Dispose of in puncture-proof containers so they do not cause injury. These items can spread HIV and HBV. Sharps containers should be colour-coded red or yellow, or at a minimum, have an infectious sharps sticker placed on the container.
- **General:** Collect in separate containers for burning or for collection by the municipal authority for disposal at the landfill. General waste may be collected into black, white or clear coloured plastic bags.
- **Infectious/clinical/pathological:** Collect in separate containers for incineration. Heavy duty yellow or red plastic bags with an infectious logo on them.
- **Cytotoxic/pharmaceutical waste:** Collect in separate containers for incineration. Cytotoxic waste should be colour-coded purple.

11.4 Safe collection of general waste

General waste does not carry harmful micro-organisms. Examples of general waste are kitchen refuse, paper waste, boxes, bottles and plastic containers that store products used by the hospital or clinic. To prevent open piles and scattering of rubbish, bins must be placed in places where they are easily accessible. Signs on general waste containers should read: “**GENERAL WASTE — NO CONTAMINATED WASTE, NO SHARPS**”.

Procedures for disposing of general waste:

1. Collect waste in leak-proof bins.
2. Place bins at convenient locations so that they will be used.
3. Encourage patients to use the bins.
4. Provide separate containers for non-burnable waste such as bottles and cans.
5. Wear thick work gloves when handling and transporting waste. This will help to prevent injury.
6. Collect bins daily or more often if needed and carry to waste area for incineration or for collection by municipal authorities. A trolley or wheel-barrow may be used to help transport waste from the hospital to the incinerator.
7. Clean up all spills immediately with a broom and shovel, and wash the area with soap and water.
8. Wash all rubbish bins with soap and water daily.
9. Wash hands after handling rubbish bins.

11.5 Safe collection and disposal of infectious and/or clinical waste

Infectious and/or clinical waste carries harmful micro-organisms and can cause infection among patients, HCWs or people in the community. Infectious and/or clinical waste is divided into four categories:

- Sharps.
- Solid clinical waste.
- Liquid clinical waste.
- Pathological waste.

Examples are used dressings, gauze or other items contaminated with blood, pus, faeces, urine, blood or body fluids; human tissue; body parts; paper specimen collection cups; pathology samples; needles; scalpel blades.

11.5.1 Sharps disposal

Procedures for collecting and disposing of sharps:

1. Wear thick work gloves when transporting sharps containers to the incinerator to prevent injury.
2. Ensure that the sharps container lid is closed or sealed with tape before transporting it to the incinerator site.
3. Collect containers daily, or more often if needed, and carry to incinerator for burning.
4. Wash hands after handling sharps containers.

11.5.2 Solid clinical waste disposal

Examples of solid clinical waste include used dressings, gauze or other items contaminated with blood, pus, faeces or other body fluids; human tissue; body parts; paper specimen collection cups. Proper disposal of solid clinical waste helps to prevent the spread of micro-organisms from contaminated waste to staff, patients and the community. Clinical solid waste should be burned or incinerated.

There should be a separate clinical waste bin with a lid. The bin should be lined with a plastic bag and should have no holes. Bins should be labelled “**CLINICAL WASTE, NO SHARPS**”

Procedures for disposing of solid clinical waste:

1. Place bins in places where they will be used
2. Wear thick gloves when handling and transporting wastes.
3. Collect bins daily, or more often if needed, and transport to incinerator for burning.
4. Clean up all spills immediately with a broom and shovel, and clean area with a neutral detergent.
5. Each day, wash waste bins with soap and water.
6. Wash hands after handling waste bins.

11.5.3 Liquid clinical waste disposal

Examples of liquid clinical waste include blood, urine, faeces, pus, sputum, spinal and peritoneal fluids, and pathology specimens. Proper disposal of liquid clinical waste helps to prevent the spread of micro-organisms from contaminated liquid waste to staff, patients and the community.

Procedures for the disposal of liquid clinical waste:

1. Wear thick work gloves when handling and transporting wastes.
2. Wear eye goggles to protect eyes from splashing
3. Carefully pour blood, urine or other body fluids directly into toilet, utility sink drain.
Avoid splashing.
4. Rinse the sink or toilet carefully and thoroughly with water.
5. When stool or sputum is collected in paper specimen cups, treat as clinical solid waste.
6. Wash hands after handling liquid waste.

11.5.4 Laboratory waste disposal

Examples of laboratory waste include used culture plates, specimen containers and specimens. The proper disposal of laboratory waste helps to prevent the spread of micro-organisms from microbiology laboratory waste and other specimens to staff, patients and the community.

An autoclave or pressure cooker is used to sterilise laboratory waste before disposal into a separate plastic bin with a yellow or red plastic bin liner labelled (in black) “**BIOHAZARD WASTE**”.

Procedures for disposing of laboratory waste:

1. Autoclave all petri dishes and test tubes that have been used to grow micro-organisms *before* incineration.
2. After sterilising, discard disposable petri dishes and test tubes into a bin marked “**CLINICAL WASTE**”.
3. After sterilising, remove the culture media from reusable petri dishes and test tubes and discard into a “**CLINICAL WASTE**” bin.
4. Wash and dry reusable petri dishes and test tubes.
5. Collect “**CLINICAL WASTE**” bins daily, or more often if needed.
6. Each day, wash bins with soap and water.
7. Wash hands after handling bins.

11.6 Handling healthcare waste bags

Procedures for handling healthcare waste bags:

1. Check that waste storage bags and containers are effectively sealed. Bags should be picked up by the neck only. They should be placed down in such a way that they can again be picked up by the neck for further handling. Waste bags should be manually handled as little as possible.
2. Bags should not be held against the body nor should collection staff attempt to carry too many bags at a time.
3. Avoid letting the bag come into contact with the body when being carried. A needle stick is the most likely hazard to endanger the person collecting the waste bag. Hypodermic needles that are not properly segregated into correct sharps containers can cause this type of injury.
4. Sharps have been known to pierce the sides and bottom of polypropylene containers. These containers should be picked up and carried by the handle provided. The other hand should not be used to support the bottom of the container.
5. Avoid puncturing or damaging waste bags, and do not throw or drop them.
6. Ensure that infectious wastes are not mixed, and that bags are stored in designated storage areas.
7. Protective clothing should be worn during all waste handling operations.
8. Transport all waste bags directly to the designated central storage for disposal.
9. Bags of hazardous healthcare waste and of general waste should not be mixed at anytime, but should be segregated throughout handling; hazardous waste should be placed only in specific storage areas. If hazardous waste is accidentally placed in general waste, the entire quantity of waste must be treated as hazardous.

11.7 Scavenging

Steps must be taken to ensure that scavenging does not take place at the hospital waste storage sites as this could be detrimental to the individual's health. The waste storage shed or area must be kept locked at all times when not attended, and care should be taken to ensure that only properly prepared and non-hazardous waste is disposed of through the municipal garbage disposal system.

11.8 Methods of solid waste disposal

11.8.1 Incineration or burning

Incineration is a process of burning wastes at very high temperatures. Incineration requires special equipment and a fuel source such as diesel or gas. Incineration is the best way to destroy contaminated wastes. The advantages of incineration and burning are that micro-organisms are destroyed by the heat, and large amounts of wastes that require considerable space are reduced to ashes.

The hospital incinerator should be housed in a locked enclosure and only used by trained operators. The incinerator must be operated in accordance with the manufacturer's instructions. Incineration equipment must be kept in good working condition and be serviced on a regular basis in accordance with the manufacturer's instructions.

11.9 Building and using a simple stove for burning wastes

In situations where incineration equipment is not available, burning can be done in a simple, large stove. Open burning is dangerous; therefore, all waste should be burned or incinerated in special stoves located in enclosed (properly fenced) areas.

Below are basic guidelines for building and using a simple stove for burning waste.

1. Select a site downwind from the healthcare facility.
2. Build a simple stove using local materials (mud or stone), or a used oil drum.
3. Place the stove on hardened earth or a concrete base.
4. Make sure the stove has:
 - Sufficient air inlets underneath to burn well,
 - Loosely placed metal bars to hold wastes and allow ashes to fall below,
 - Enough space to add waste at the top and to remove ashes from below,
 - Long enough chimney to allow for good draught and removal of smoke.
5. Burn all burnable waste, such as paper and cardboard, as well as dressings and other contaminated wastes.
6. If the waste is wet, add kerosene so that a hot fire burns all the waste. Store waste for incineration in covered rubbish bins.
7. Ash from the stove or incinerator can be treated as non-contaminated waste. Note, however, that sharps, even after incineration, may be dangerous and should be buried (see below).

Figure 11.1 Simple stone or mud incinerator

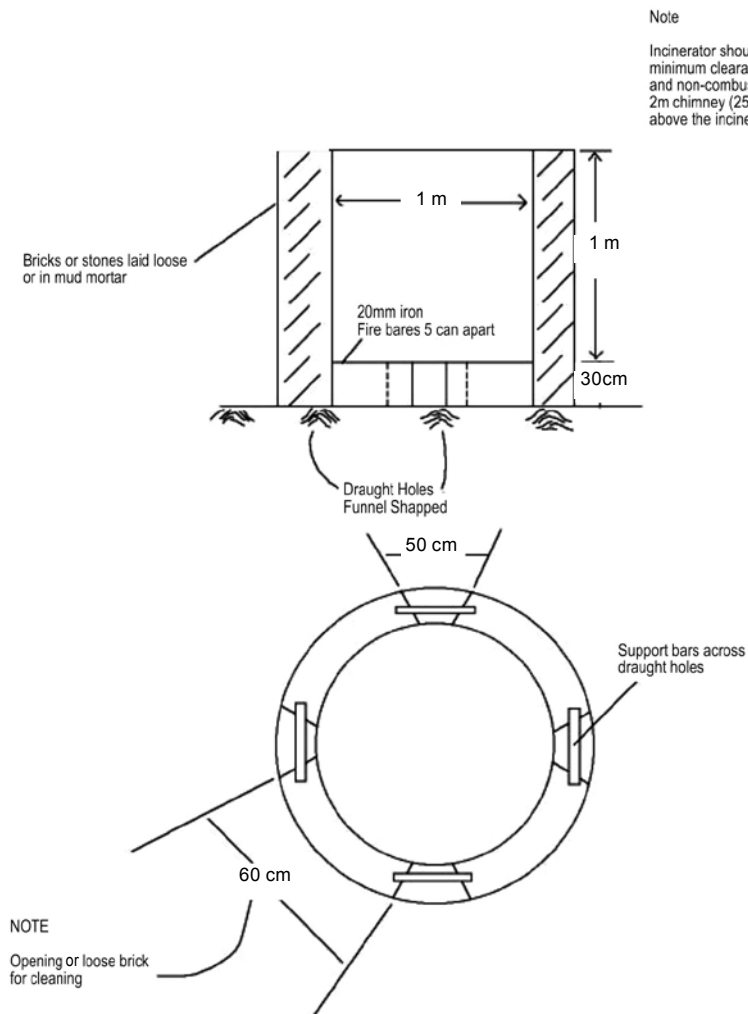

Source: Adapted from Fiji Ministry of Health, Infection control manual for health facilities.

Figure 11.2 Simple oil drum incinerator

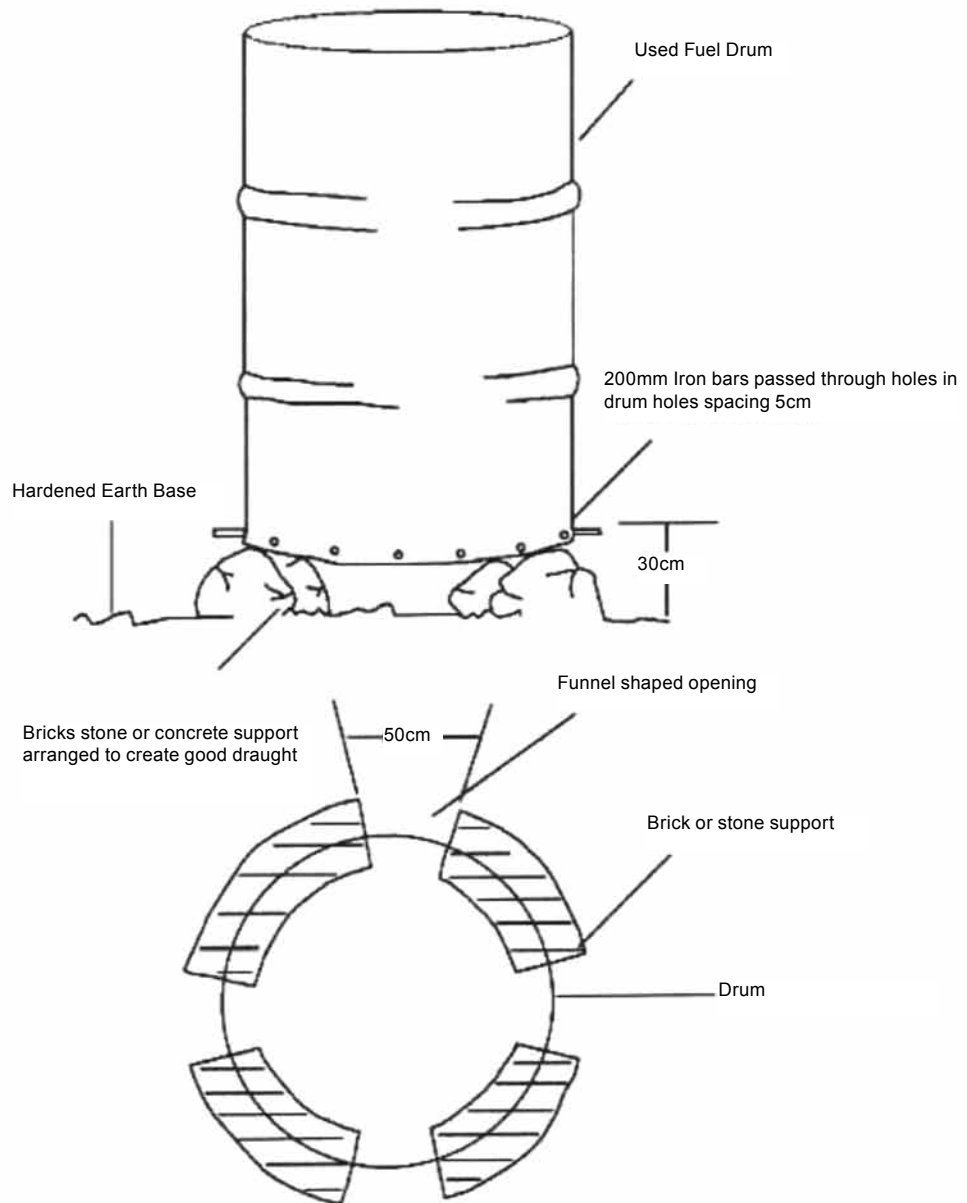

Source: Adapted from the Fiji Ministry of Health 2002, Infection control manual for health facilities.

11.10 Waste disposal by burying

When clinical and non-clinical wastes cannot be burned or incinerated, waste must be buried. Even if wastes are collected by a city collection system, it is good for healthcare administrators to make sure the waste is disposed of safely. When wastes are buried, certain requirements must be met so that children and animals cannot dig up the waste.

Note: Sharp objects may not be destroyed by burning and may later spread tetanus infection. Dispose of all sharp objects by putting them underground, even after burning.

Procedures for making and using an underground waste disposal site:

1. Select a site that:
 - is at least 50 meters (150 feet) away from any water source, to prevent contamination of the water supply.
 - has proper drainage, is located downhill from any wells, and is free of standing water.
 - is not in an area that floods.
2. Dig a pit 1 meter (3 feet) wide and 2 meters (6 feet) deep. The bottom of the pit should be 2 meters above the water table.
3. Fence in the site to keep animals and children away.
4. Wear heavy gloves when handling waste buckets.
5. Empty buckets of non-burnable waste into the pit every day.
6. Cover the waste with a thin layer of earth each day. The final cover should be 10 centimetres deep.

Note: General waste is the only waste that can be disposed of in a municipal garbage facility (i.e. landfill). It is illegal and dangerous to dispose of other wastes with municipal garbage.

Table 11.1 Safe waste disposal

	Waste type	Waste bag colour	Disposal
General waste	Kitchen refuse, paper waste, boxes, bottles, plastic containers	black	Local level govt. collection/ incineration
Sharps	Needles, broken or disposal syringes, razors, lancets, scalpel blades	sharps container yellow or red	Incinerate, then bury
Solid infectious and/or clinical waste	Dressings, gauze, or other items contaminated with blood, pus, faeces or other body fluids; human tissue; body parts; paper specimen collection cups	yellow or red	Incinerate
Liquid and clinical waste	Blood, urine, faeces, pus, sputum, spinal and peritoneal fluids, pathology specimens	no bags	Drain fluids into toilet or utility sink; or place in contaminated waste bin, and incinerate
Laboratory waste	Used culture plates, specimen containers, specimens	yellow or red	Sterilise, place in contaminated waste binds, and incinerate
Cytotoxic waste	Cancer treatment drugs and used consumables	purple	Incinerate
Pharmaceutical waste	Tablets, mixtures and injectables	yellow	Incinerate

11.11 Garbage storage and disposal

Garbage should be removed at least twice daily and no garbage should be left in kitchen areas overnight. Not only are many common pests capable of transmitting infection, but the sight of insects and pests within the hospital environment can be very disturbing to patients, staff and visitors alike. It is, therefore, a basic requirement of the hospital cleaning programme that adequate attention be paid to preventive and protective measures designed to minimise this potential form of cross infection.

In general, six elements are essential in any effective programme for the control of pests in a hospital.

- Thorough, constant cleaning of all potential areas of infestation.
- Regular, careful inspections for evidence of pests.
- Storage of waste and garbage in water-tight containers.
- Thorough cleaning of all garbage containers after use.
- Daily removal of all stray garbage not placed in correct receptacles.
- Proper storage of all goods and supplies likely to attract pests.

12 INFECTIONS CAUSED BY ANTIMICROBIAL-RESISTANT ORGANISMS

12.1 Introduction

The inappropriate use of antimicrobial agents can lead to the emergence of resistant organisms which can cause infections in healthcare facilities and in the community. Multi-resistant organisms in healthcare facilities are easily transmitted when basic infection control practices are not followed. Most healthcare facilities have national antibiotic and disinfection guidelines as well as drug and therapeutic committees that monitor the inappropriate use of antimicrobials.

12.2 Methicillin- and vancomycin-resistant *Staphylococcus aureus*

Outbreaks of methicillin-resistant *Staphylococcus aureus* (MRSA) are becoming a concern for healthcare facilities, as strains are often resistant to several antibiotics and are often sensitive only to vancomycin and one or two other antibiotics. There have also been reports of *Staphylococcus* that is resistant even to vancomycin (vancomycin-resistant *Staphylococcus aureus* or VRSA). MRSA can spread very rapidly once it is isolated in just one patient. Transmission of MRSA infection has been implicated through the contaminated hands of healthcare staff, and result from poor compliance with hand hygiene. Patients may have an active MRSA infection or may be merely colonised with it (*S. aureus* is found normally on human skin). It is important to note that patients colonised with MRSA — especially common in diabetic patients — have no systemic illness. Patients colonised with MRSA do not need antibiotics as opposed to patients that have a systemic MRSA infection who must be treated. It is advisable to consult with a healthcare facility's antibiotic guidelines.

The following strategies prevent the further spread of MRSA.

- Isolate known MRSA-colonised or -infected patients in a contact isolation room (negative pressure is not necessary). If more than one patient is involved, then patients should be grouped together in a ward.
- Implement standard and contact precautions.
- Conduct daily environmental cleaning

12.3 Vancomycin-resistant *Enterococcus*

Enterococci are bacteria that are normally present in the intestinal tract of healthy people. Vancomycin is an antibiotic to which some strains of enterococci are resistant; these are referred to as vancomycin-resistant enterococci (VRE). Healthy people can be colonised with VRE and may not show any signs of infection. VRE is transmitted from person to person through direct and indirect contact, often via the hands of HCWs.

People who are at risk of being colonised or infected with VRE include:

- Critically ill patients in intensive care units.
- Immunocompromised patients (patients on chemotherapy).
- Patients undergoing or who have recently had major surgery.
- Patients who have central venous lines and urinary catheters.
- Patients who have been in the hospital for a prolonged stay.
- Patients who have received vancomycin and many other antibiotics.

Infection control measures are the same as those for MRSA patients.

13 INFECTIONS BY SELECTED DISEASES

This section and the next two sections are dedicated to selected diseases that are either present in the region or may become present and are of importance to healthcare settings.

13.1 *Dengue fever, malaria and leptospirosis*

An awareness of dengue fever, malaria and leptospirosis and their prevention, together with the effective control of mosquito and vermin breeding, underpins successful control of these diseases and many others. Good workplace housekeeping and institutional management lessens the presence of rodents and insects within the healthcare facility and reduces the prospect of disease and contamination to patients and staff. It is also important that environmental health officers are involved in preventative activities in hospitals during peak periods of the diseases mentioned below.

13.1.1 Dengue fever

Dengue is spread by mosquitoes belonging to the genus *Aedes*. The main species responsible for transmission of dengue fever and dengue haemorrhagic fever are *Aedes aegypti* and *Aedes albopictus*.

Aedes aegypti breeds inside and outside of buildings in artificial containers that store water (e.g. pot plants, water storage drums). *A. albopictus* can breed in scant amounts of water and in naturally occurring water collection areas such as tree holes.

When dried under natural conditions, *Aedes* sp. eggs remain viable for six months. Transmission of dengue virus may be either immediate (if the mosquito's blood meal is interrupted and it changes host), or delayed (occurring one week after feeding on an infected host when virus load in the mosquito's salivary gland is high).

13.1.2 Suspicion of a dengue outbreak

A sudden increase in the number of patients suffering from an undiagnosed febrile illness is characterised by the following.

- High fever for 2 to 7 days.
- Failure of cases to respond to treatment for commonly occurring febrile illnesses in the affected area.
- Unexplained deaths with or without haemorrhagic event within one week of onset of febrile illness.
- Febrile patients present with one or more haemorrhagic event (petichiae, epistaxis, gum bleeding, haematemesis or melena).
- Febrile patients remain ill despite drop in temperature; the clinical condition deteriorates with development of cold and/or clammy skin, drowsiness and restlessness.

13.1.3 Dengue prevention and control activities

Identification and elimination of actual and potential breeding sites and sites that harbour adult mosquitoes is very important.

In healthcare facilities, the following receptacles have the potential to store water, and thus breed mosquitoes:

- flower vases
- disused toilet cisterns and pans
- sterilisers and other equipment which are out of service
- receptacles used for collecting and storing water:
 - leakage from sink plumbing
 - leaking roofs
 - water for hand washing during water shortages.

A good housekeeping policy should be developed and rigidly implemented.

Outdoors, the following measures should be taken:

- Cover all receptacles used for water storage.
- Implement solid waste management in accordance with hospital or healthcare facility policy.
- Promote the basic rule of “reduce, recycle, reuse”.
- Remove features that promote the stagnation of water.
- Modify architectural features that promote the stagnation of water.
- Remove accumulated debris, such as tires and abandoned cars.
- Control overgrown vegetation within a 100-m radius of every building.

Long-term measures to minimise exposure to mosquitoes should include:

- Screening all windows.
- Meticulous attention to self-closing doors to minimise migration of mosquitoes in high patient/staff density areas.
- Encourage personal protection for all patients and hospital employees who are on healthcare facility premises at peak biting times (i.e. early morning and evenings).

Measures to minimise in-house transmission during a dengue epidemic include:

- Require use of (preferably insecticide-impregnated) mosquito nets by patients admitted to the healthcare facility in the acute phase of dengue infection.
- Encourage use of insect repellent preparations by staff and patients.
- Continuous repellent use is not recommended, to avoid toxicity.
- Repellent use should coincide with peak biting times.

Note: In areas occupied by patients and HCWs, use only electronic mosquito destroyers, mosquito coils and household insecticide sprays. Professional insecticide treatment of unoccupied and/or dead spaces and the external environment should be restricted to the use of available space spraying techniques.

Awareness of dengue fever and its prevention, together with the effective control of vector breeding, underpins the successful control of the disease. Every employee of the healthcare facility should attend a minimum of two hours of dengue-related education and training during a 12-month period.



Every patient admitted to a healthcare facility during dengue high risk periods should be counselled upon admission, and provided an information brochure (where available) on dengue fever and personal protection measures.

Dengue awareness is to be integrated in other health education activities conducted at all service delivery points in the healthcare facility.

13.2 Malaria

Malaria is caused by parasites belonging to the genus *Plasmodium* and spreads from person to person through the bites of infected mosquitoes. There are four main types of human malaria: *Plasmodium falciparum*, *P. vivax*, *P. malariae* and *P. ovale*. *P. falciparum* and *P. vivax* are the most common. *P. falciparum* is by far the most deadly type of malarial infection. The common initial symptoms — fever, headache, chills and vomiting — appear 10–15 days after a person is infected. If not treated promptly with effective medicines, malaria can cause severe illness that is often fatal.

13.2.1 Malaria prevention

The main objective of malaria vector control is to significantly reduce both the number and rate of parasitic infections of clinical malaria by controlling malaria-bearing mosquitoes and reducing and/or interrupting transmission. This is achieved by:

- Indoor residual spraying of a long-acting insecticide.
- Using long-lasting insecticidal nets, which can be complemented by other methods (e.g. larval control activities).
- Education on malaria by HCWs.

13.3 Leptospirosis

Leptospirosis is an acute febrile disease (with potentially lethal outcomes) caused by bacteria that affects humans and other animals. It is spread by contact with urine from cattle, dogs, mongooses, pigs, rats and from water or soil contaminated with the urine from these species. Outbreaks occur among those exposed to stagnant and slow flowing water contaminated by the urine of domestic or wild animals. Entry of leptospira bacteria into the human body occurs by penetration of intact, diseased and damaged skin.

13.3.1 Symptoms of leptospirosis

Symptoms of this disease are fever, headache, chills, severe malaise, vomiting and muscle pains. As the disease advances, the liver, kidneys, blood and brain are affected. Involvement of the liver and kidneys may cause death from organ failure. Leptospirosis is a deadly disease if left unattended, although it carries a good prognosis if detected and treated early.

Suspicion of a leptospirosis outbreak (clinical case definition) includes:

- High fever of sudden onset.
- Severe headache.
- Severe myalgia (especially in thighs, calves and loins).
- Conjunctival suffusion (red eyes).

13.3.2 Leptospirosis control and prevention activities

Measures to control and prevent leptospirosis include:

- Avoid swimming or wading in waters that may contain the *Leptospira* bacteria.
- Wear protective gloves and boots while working in areas suspected of having been exposed to the bacteria (e.g. farms, abattoirs, rivers, ponds, sewage plants).
- Eliminate rats and mice in homes, schools and buildings.
- Protect food and drinking water from rats and domestic animals.
- Dispose of rubbish properly.

Controlling rodents, insects and related pests that live in close association with humans is of essential to public health. The presence of rodents and insects within and around healthcare premises is a measure of the status of workplace housekeeping and institutional management, and serves as a yardstick for implementation and evaluation of control programmes.

While a detailed discussion of vermin control is beyond the scope of this document — for complete advice, an expert in pest control should be consulted — the following general rodent and insect control measures should be taken.

- Food storage, preparation, delivery and consumption areas should be structurally rodent and insect proof.
- Refuse bins with tight fitting lid should be provided, and bins should be properly cleansed after daily disposal.
- All internal refuse bin storage areas should be fully screened or rodent proof.
- Food storage and preparation areas should be cleaned monthly.
- Monthly pest control activities (e.g. setting out poison baits).

Outdoors, control measures include:

- Control overgrown weeds within a 100-m radius of all hospital buildings.
- Screen external garbage bin storage areas from insects, rodents and other animals.
- Install grating within roof gutters and down pipe connectors.
- Install grating to all sub-drainage inlets.
- Conduct a monthly inspection of all drainage and sewer lines, inspection chambers and manhole covers.
- Remove excess debris (e.g. woodpiles, car parts) that may provide shelter for vermin.

14 MYCOBACTERIUM TUBERCULOSIS

14.1 Introduction

Mycobacterium tuberculosis (TB) is carried in airborne particles that are generated when people with TB sneeze, cough or speak. The infectious particles are an estimated 1–5 μm in diameter, and normal air currents can keep them suspended and airborne for days. Infection, which is usually asymptomatic, occurs when a susceptible person inhales particles containing *M. tuberculosis* and the organisms reach the alveoli (deep part) of the lungs. Once in the lungs, the organisms are taken up by the alveolar macrophages and may spread farther throughout the body.

Disease, which is usually accompanied by focal and generalised symptoms, may develop soon after infection. In most people, however, an immune response is generated within 2–10 weeks after infection, which limits further multiplication and spread of the tubercle bacilli. Some of the bacilli may remain dormant and viable for many years (i.e. latent infection with *M. tuberculosis*). Individuals with latent infection do not have symptoms of active TB and are not infectious.

14.2 When TB is infectious

TB can be infectious when it occurs in the lungs or larynx. In general, a person with TB of the lungs or the larynx should be considered infectious until the person has:

- completed at least two weeks of standard anti-TB therapy, preferably with direct observation by a TB programme appointed treatment supervisor;
- had three consecutive negative sputum smears with at least one morning specimen; and
- improvement in symptoms.

A TB suspect should be considered infectious until a diagnostic investigation is completed.

14.3 Infection control strategies

There are three levels of infection control measures: administrative, environmental and personal respiratory protection. Administrative controls are the most important. Each level operates at a different point in the transmission process.

- Administrative controls reduce healthcare worker and patient exposure.
- Environmental controls reduce the concentration of infectious particles.
- Personal respiratory protection protects healthcare workers in areas where the concentration of infectious particles cannot be adequately reduced by administrative and environmental controls.

The first and most important level of control is the use of administrative measures to prevent infectious particles from being generated, and thus reducing the exposure of HCWs and others.

Important administrative measures include early diagnosis of potentially infectious TB patients,

prompt separation or isolation of infectious TB patients, and prompt initiation of appropriate anti-TB treatment. Other important measures include an assessment of the risk of transmission in the facility, the development of an infection control plan, and adequate training of HCWs to implement the plan.

Since the exposure to infectious particles usually cannot be eliminated, various environmental control methods can be used in high risk areas to reduce the concentration of particles in the air. Such measures include maximising natural ventilation and controlling the direction of airflow (opening windows to increase natural ventilation and using fans to control the direction of air flow).

The third recommended control measure is protecting healthcare workers from inhaling infectious particles through the use of personal respiratory protective devices that are designed to fit over the mouth and nose and filter out infectious TB particles. The use of these protective devices should be restricted to specific areas where TB patients are located. If a respirator is needed, a USA-certified N95 or EU-certified FFP2 respirator should be used. Respirators are different from face masks, such as surgical masks made of cloth or paper. Using a face mask does not protect healthcare workers, other staff, patients, or visitors against TB. Therefore, it is NOT recommended that healthcare workers wear them for TB protection.

14.4 *Multi-drug resistant TB*

Multi-drug resistant TB (MDR-TB) is transmitted in the same way as drug-susceptible TB. Because MDR-TB patients may respond to treatment slowly and remain sputum smear-positive longer than other TB patients, they may infect more people.

Recommendations for the control and prevention of MDR-TB are essentially the same as those for drug-susceptible TB, with only minor differences in emphasis.

An important aspect of administrative control measures is the physical separation of patients known or suspected to have TB or MDR-TB from other patients, especially those who are immunocompromised. If isolation rooms are not available, a less satisfactory solution is to separate, rather than isolate, patients. Patients with TB are grouped together and are kept apart from those with suspected MDR-TB, who are grouped together. Patients with different drug resistance patterns should not be housed together.

14.5 *TB and HIV*

People with undiagnosed, untreated and potentially contagious TB are often seen in HIV care settings. TB is the most common opportunistic infection and a leading cause of death in people living with HIV/AIDS. People with HIV-associated immunosuppression may become infected or reinfected with TB if they are exposed to someone with infectious TB disease. They can progress rapidly from a TB infection to TB disease over a period of months.

Each HIV care facility should have a written TB infection control plan that outlines a protocol for the prompt recognition, separation, provision of services, investigation for TB, and referral of patients with suspected or confirmed TB disease.



Because of the risk of severe morbidity and mortality to HIV-infected persons from TB, people known to have TB should receive routine care outside of normal HIV care settings. The risk of transmission to patients and HCWs decreases when community-based ambulatory treatment is established and hospital stays are reduced. Although transmission is likely to have occurred before the diagnosis and start of treatment, ambulatory patients should be advised to avoid contact with the general public and with particularly susceptible people, such as young children or individuals with HIV infection.

14.6 Protection of healthcare workers

Investigations have documented that the risks of TB disease or infection to HCWs are greater than those to the general population.

Recommended infection control measures should reduce the risk to staff, nevertheless, the risk to staff will never be zero, and an additional aspect of protecting staff is promoting early recognition of TB disease and standard treatment.

Annual screening programmes for TB disease, such as annual chest radiography, have not been shown to effectively reduce the amount of time between developing symptoms and diagnosis, as only a fraction of those who develop TB do so around the time of screening. Instead, reminders that healthcare workers and other staff can develop TB, regardless of previous infection status or BCG vaccination should occur with annual re-training on infection control. It is recommended that staff be investigated for TB free of charge if they have a cough that lasts for two weeks or more.

Tuberculin skin testing can diagnose people with TB infection who are most likely to develop TB disease. TB preventive therapy for HIV-infected healthcare workers should be considered.

In laboratories where only smear microscopy is performed, personal respiratory protection is not needed, and the greatest threat to personnel is probably contact with coughing patients. Administrative measures should be used to limit this exposure.

15 HUMAN INFLUENZA, AVIAN INFLUENZA INFECTING HUMANS, AND PANDEMIC INFLUENZA

A full discussion of these diseases is beyond the scope of this document. Readers are referred to WHO's guidelines on clinical infection control of avian influenza and pandemic influenza website:

http://www.who.int/entity/csr/disease/avian_influenza/guidelines/infectioncontrol1/en/index.html

15.1 Human influenza

Influenza virus, which is more commonly known as the “flu”, is very infectious and spreads very quickly between humans. The influenza virus mainly attacks the upper respiratory tract. People with influenza usually present with a sudden onset of high fever, muscle aches, headache and severe malaise, non-productive cough, sore throat and rhinitis. Influenza viruses type A and occasionally type B are the cause of annual epidemics of influenza.

15.1.1 Mode of transmission

Influenza virus is spread via droplets when infected people cough, sneeze or speak causing the virus to settle on the mucous membranes of the eyes, mouth and respiratory passages of another person. The virus is also mainly spread through contaminated hands, either through direct contact with an infected person or indirect contact through touching environmental surfaces contaminated with the influenza virus.

Infection control measures to prevent the spread of influenza include the implementation of standard plus contact and droplet precautions (see Section 4).

15.2 Avian influenza infecting humans

15.2.1 Avian influenza

Avian influenza is an infectious disease of birds and is caused by type A strains of the influenza virus. It is now well known that the avian influenza virus is naturally found among migratory waterfowl and wild ducks. Direct and indirect contact between migratory water fowl and wild ducks and domestic and commercial poultry have been the cause of frequent outbreaks of avian influenza in Southeast Asia since 2003.

15.2.2 Avian to human avian influenza (H5N1 transmission)

Since the beginning of the avian influenza outbreak in November 2003, the number of human cases of avian influenza has been reported in 15 countries, with Indonesia reporting the highest number of cases, followed by Vietnam. (WHO avian influenza update December 2009).

Current evidence suggests that the H5N1 virus transmission to humans occurs via bird to human. The risk factors of acquiring human avian influenza virus include:

- Contact with sick birds infected with avian influenza via plucking and preparing sick birds for cooking.



- Handling fighting cocks that are sick with H5N1 virus and playing with sick birds.
- Consumption of undercooked sick poultry

Infection control measures when caring for humans infected with avian influenza include:

- standard plus contact and droplet precautions when providing routine care; and
- standard plus contact and airborne precautions when performing aerosol generating procedures such as suctioning, intubation or administration of nebulised medication.

For further information on avian influenza in humans refer to:

- www.who.int/csr/resources/publications/AI_Inf_Control_Guide_10May2007.pdf
- http://www.who.int/csr/resources/publications/WHO_CDS_EPR_2007_8/en/index.html
- <http://www.cdc.gov/flu/avian/gen-info/avian-influenza.htm>

15.3 *Pandemic influenza*

A pandemic virus outbreak occurs when:

- a completely new virus is formed;
- the new virus causes infection in humans;
- the new virus spreads very easily between humans; and
- there is no immunity in the population.

15.4 *Infection control principles to slow a pandemic virus*

It is well documented that influenza virus spreads from human to human via contact with droplets (see mode of transmission for human transmission Section 15.1). Droplets do not stay in the air for long and only travel up to one metre or less.

Infection control measures include:

- Standard plus Contact and Droplet Precautions.
- Isolation of infected patients in a single room or cohort patients with the same symptoms in a defined room.
- Spatial separation one meter apart between patients in common waiting areas, as well as between beds when patients are grouped together.
- Appropriate use of PPE, especially the choice of appropriate masks, and when removing PPE, the right sequence and technique must be followed. (see Fig. 4.3)
- Avoid procedures that generate aerosols (e.g. administration of aerosolised medications), unless adequate PPE is available, especially a particulate N95 mask.
- Adherence to respiratory hygiene cough etiquette (see Section 4.2)
- Strict adherence to hand hygiene.

15.5 *Infection control in the community setting*

During the pandemic, there may be a shortage of beds. When sick patients cannot be admitted to the hospital, they must remain at home. The same principles of infection control must apply in the home.

BIBLIOGRAPHY

AIDS/TB Committee of the Society for Healthcare Epidemiology of America. 1997. Management of healthcare workers infected with hepatitis B virus, hepatitis C virus, human immunodeficiency virus, or other bloodborne pathogens. *Infection Control and Hospital Epidemiology* 18:349–363.

Australian Government Department of Health. 2006. Interim infection control guidelines for pandemic influenza in health care and community settings. Available from: <http://www.health.gov.au/internet/wcms/publishing.nsf/Content/ohp-pandemic-infect-control-gl-toc.htm>

Centers for Disease Control and Prevention. 1998. Guideline for infection control in healthcare personnel. *American Journal of Infection Control* 26(3)

Centers for Disease Control and Prevention. 2007. Sequence for donning and removing PPE. Available from <http://wwwtest.cdc.gov/ncidod/sars/pdf/ppeposter148.pdf>

Chin J. (ed). *Control of communicable diseases manual*, 17th ed. American Public Health Association: Washington. DC.

Collingnon P. and Carnie J. 2006. Infection control and pandemic influenza, eMJA supplement. Available from: http://www.mja.com.au/public_issues/185_10_201106/

Communicable Diseases Network Australia. 2002. Infection control guidelines for the prevention of transmission of infectious diseases in the healthcare setting, 2nd ed. Commonwealth Department of Health and Ageing, Commonwealth of Australia. Canberra, Australia.

Donowitz L. 2000. *Infection control for the healthcare worker*, 3rd ed. University of Virginia School of Medicine. Virginia, USA.

Fiji Ministry of Health. 2002. *Infection control manual for health facilities*. Fiji Ministry of Health, Suva, Fiji.

Garner J. 1996. Guideline for isolation precautions in hospitals. The Hospital Infection Control Practices Advisory Committee. *Infection Control and Hospital Epidemiology* 17(1):53–80.

Gerberding JL. 2003. Occupational exposure to HIV in healthcare settings. *New England Journal of Medicine* 348:826–833.

Heymann D. (ed). 2004. *Control of communicable diseases manual*, 18th ed. American Public Health Association. Washington DC.

National Drugs and Therapeutics Committee. 2004. *National antiretroviral therapy guidelines*, 1st edition. Fiji Ministry of Health, Suva, Fiji.



Oceania Society for Sexual Health and HIV Medicine, July 2007. Managing of potential exposures to bloodborne viruses including HIV in health care settings, pages 37–46.

Pruss A., Giroult E. and Rushbrook P. (eds). 1999. Safe management of wastes from health-care activities. World Health Organization. Geneva, Switzerland. Available from: <http://whqlibdoc.who.int/publications/924154529.pdf>

Sehulster L., Chinn R., CDC and HICPAC. 2003. Guidelines for environmental infection control in health-care facilities. Recommendations of CDC and the Healthcare Infection Control Practices Advisory Committee. MMWR Recomm Rep. 52(RR-10):1–42.

World Health Organization. 2002. Prevention of hospital acquired infections – A practical guide. 2nd ed. World Health Organization Geneva, Switzerland.

World Health Organization. 2003. Practical guidelines for infection control in health facilities. Available from: whqlibdoc.who.int/wpro/2003/a82694.pdf

World Health Organization. 2004. Practical guidelines for infection control in healthcare facilities. World Health Organization, India.

World Health Organization. 2005. WHO guidelines on hand hygiene in healthcare (advanced draft): A summary. World Health Organization. Geneva, Switzerland.

World health Organization. 2005. Guidelines for the programmatic management of drug-resistant tuberculosis. (WHO/htm/tb/2006.361) World health Organization. Geneva, Switzerland. 2005.

World Health Organization. 2005. World alliance in patient safety, guidelines on health hygiene in health care. Available from: http://www.who.int/patientsafety/events/05/HH_en.pdf

World Health Organization. 2006. Avian influenza, including influenza A (H5N1), in humans: WHO interim infection control guideline for health care facilities. Available from: www.vfda.net/WHOInterimGuidelinesfor.pdf

World Health Organization. 2007. Malaria fact sheet No. 94. Available from: <http://www.who.int/mediacentre/factsheets/fs094/en/>

World Health Organization and Centers for Disease Control and Prevention. 1998. Infection control for viral haemorrhagic fevers in the African healthcare setting. World Health Organization. Geneva, Switzerland. Document no. WHO/EMC/ESR/98.2. Available from: http://www.who.int/enc-documents/haem_fever/whoemcesr982c.html

World Health Organization. 1999. Tuberculosis infection control in the era of expanding HIV care and treatment. Addendum to WHO guidelines for the prevention of tuberculosis in health care facilities in resource limited settings, 1999.

ANNEX 1: OCCUPATIONAL EXPOSURE REPORT FORM

Hospital or workplace:

Report completed by:

Date & time of exposure:

Date & time of report:

1. The injury occurred in which work area?

- Medical ward
- Surgical ward
- Operating room
- ICU
- Nursery
- Labor ward
- Laboratory
- Other

2. Job classification of the injured worker?

- Dentist
- Technician
- Housekeeper/laundry
- Doctor
- Nurse
- Student
- Security
- Other

3. How did the incident occur?

- Patient moved and jarred device
- While inserting needle in line or patient
- While withdrawing needle from line/patient
- Passing/transferring equipment
- Suturing
- Recapping
- Disassembling device/equipment
- Opening/breaking glass container
- Injured by sharp being disposed
- Over-filled sharps container
- Sharp in in-proper place (general waste, linen etc.)

4. What type of device caused the injury?

- Hollow bore needle
- Glass object
- Non-healthcare item
- Other sharp object
- Unknown
- Other

5. When in the use of the object did the exposure occur?

- Before contact with source blood or body fluid
- Following contact with source blood or body fluid
- Unknown
- Other

6. Type of exposure

- Percutaneous
- Mucous membrane
- Non-intact skin
- Intact skin

7. Part of body injured:

8. Type of body fluid exposed to:

9. Was first aid given?

- YES
- NO

10. Were gloves worn?

- YES
- NO

11. Was staff member vaccinated against Hepatitis B?

- YES
- NO

12. When was vaccination given (year)?

13. Post immunization HBsAb tested?

- YES
- NO

14. Considered immune?

- YES
- NO

15. Was physician on-call contacted?

- YES
- NO



16. Was Hepatitis B immunoglobulin given?

- YES NO

17. Is anti-retroviral therapy required?

- YES NO

18. Baseline Serology

(if performed/consented)

- HBV
 HCV
 HIV
 Other

19. Follow up required?

- YES NO

SOURCE FOLLOW UP

Source name (if known):.....

Source agreed to blood tests?

- YES NO

ANNEX 2: CONSENT FORM FOR POST-EXPOSURE PROPHYLAXIS

I,, have been duly provided with all the necessary information in order for me to make an informed choice. I therefore accept/not accept [delete one] post-exposure prophylaxis as per Needle-Stick Injury Protocol.

Signature of exposed HCW

Signature of Attending Clinician

Completed forms must be submitted to the infection control officer



ANNEX 3: HIV COUNSELLING FORM CHECKLIST

1. *What the test means:*

- **Elisa** test is looking for antibodies, not the virus itself.
- **Time Frame** “Window Period”: 2–12 weeks.

2. *What a positive result means with regards to:*

- Medical Aspects.
- The infection is life long and you can pass on the virus from time of infection.
- Modes of transmission are from exposure to blood and body fluids i.e. through a needle stick injury, sexual intercourse with an infected partner or sharing of used needles and syringes.
- Medical progression is such that you may be well for many years before experiencing other symptoms progressing to **AIDS**.

3. *Psychological aspects:*

- Thinking through possible results.
- Have you thought about the test being positive? How do you think you would feel?
- Assessing coping ability. How have you coped before with stressful life events?
- Back up services available if unable to cope while waiting for results.

4. *Notification requirements:*

- **HIV** positive results – testing laboratory notifies Ministry of Health – all that is required is:
 - **DOB:**
 - **SEX:**
 - **MODE OF TRANSMISSION:**

5. *Social aspects:*

- Client’s legal obligation – inform current and future sexual partners of infection.
- Discussion re: family, friends and support.
- Need for care re disclosure – should your test be positive – be selective who you discuss this with.
- Implications for travel, housing, employment.

6. *Travel:*

- Some countries will not allow HIV positive people to visit i.e. America.
- Other countries will not allow HIV positive people to work and for this reason when applying for an overseas work permit you may be asked to supply a recent HIV result – Countries include Australia and the Emirates.

7. *Housing:*

- People who are HIV positive may also experience some difficulties with long term housing loans.

8. *What a negative result means:*

- Interpreted in relation to time frame of test/risk practices

9. *Preventive aspects (whatever the test result):*

- Safer needle and syringe use
- Reinforce non sharing of needle and syringes
- Safer sex practices.
- Information re condoms, high and low risk sexual practices. Check the expiry date on condoms and if this is a month of expiring, a new pack should be used. Also give instructions on how to apply a condom in the correct way i.e. Ensure the air bubble at the end of the condom is firmly clasped expelling the air while rolling down the shaft of the penis.

10. *How results of tests are obtained:*

- All staff MUST receive results **face to face, never over the phone.**

11. *Counselling on drug therapy:*

- Toxicity and side effects profile of drugs. Patients must be made fully aware of the associated side effects of these drugs.
- Monitoring and evaluation of Post Exposure Prophylaxis.

ANNEX 4: POSITION DESCRIPTION

Position: Infection Control Nurse/Officer

Primary purpose

Responsible for the overall co-ordination, implementation and monitoring of the infection control policies and procedures, conduct relevant training, education and provision of relevant advice in hospitals and other health facilities.

Duties and responsibilities

1. Maintain close liaison with all departments to provide advice on matters relating to infection control and to ensure adherence on infection control guidelines.
2. Ensure ongoing review and update of all policies and procedures in relation to infection control in line with new developments and changing trends.
3. Participate as the principal working member of the Infection control committee and act as secretary to the committee.
4. Deliver verbal and written infection control reports in the required format to the infection control committee.
5. Provide all new staff with infection control orientation and maintain ongoing Infection Control education programs for all staff.
6. Investigate specific outbreaks of nosocomial infection in order to identify specific procedures that may constitute a risk of infection transmission.
7. Review usage of all chemical cleaning products and antiseptics to ensure appropriateness of products and usage.
8. Ensure appropriate follow up of staffs who suffer occupational accidents involving blood and body substances.
9. Be involved in the development of staff health programs in relation to hepatitis B immunisations and any other infectious disease related matter.
10. Establish and maintain ongoing surveillance on the occurrence of nosocomial infection.
11. Develop, update and implement infection prevention techniques according to current standards of practice, which provide optimum care to patients with infections.

ANNEX 5: HOW TO MAKE AN ALCOHOL HANDRUB

Measure: 100 ml 70% Isopropanol

Measure: 3 ml glycerine (using a syringe)
Or use 5 ml of “Sorbitol”

Squirt glycerine into alcohol and mix. The glycerine will protect your hands from dryness caused by the alcohol.

Directions for use

Apply about 3 ml of the product to the palm of one hand and rub hands together covering all surfaces of the hands and fingers until hands are dry (about 20–30 seconds).

If hands are dried within 10–15 seconds then not enough hand rub was used.

ANNEX 6: HOW TO PREPARE SODIUM HYPOCHLORITE SOLUTION FOR DISINFECTION

Sodium hypochlorite is more commonly known as household bleach and is a very effective disinfectant in killing bacteria, fungi and viruses including the influenza virus. Sodium hypochlorite can be easily diluted from the household bleach concentration at the local pharmacy for disinfection of patient equipment and environmental surfaces.

Bleach precautions

- Bleach can be corrosive to metals and damage painted surfaces.
- Use mask, household rubber gloves, goggles (to protect eyes from splashes) and waterproof apron when preparing diluted bleach.
- Mix the bleach in a well ventilated area with cold water because hot water decomposes the sodium hypochlorite.
- If bleach gets into the eyes, immediately rinse with water for 15 minutes and consult a doctor.
- Diluted bleach should be made fresh daily, labelled, dated, and unused portions should be discarded 24 hours after preparation.
- Organic materials inactivate bleach; surfaces must be cleaned of organic materials prior to disinfection with bleach.
- Bleach should NEVER be used together with, or mixed with, other household detergents because this reduces its effectiveness and can cause chemical reactions.
- A toxic gas is produced when bleach is mixed with acidic detergents such as those used for toilet cleaning and this gas can cause death or injury. If necessary, use detergents first and rinse thoroughly with water before using bleach for disinfection.
- Undiluted bleach liberates a toxic gas when exposed to sunlight and should be stored in a cool, shaded place out of the reach of children.

Sodium hypochlorite concentration and use

Starting Solution	Most household bleach ¹ contains 5% sodium hypochlorite (50,000 parts per million available chlorine)
Recommended chlorine	1:100 dilution of 5% sodium hypochlorite is the usual recommendation. Use 1 part bleach to 99 parts cold tap water (1:100 dilution) for disinfection of surfaces.
Available chlorine after dilution	For bleach preparations containing 5% sodium hypochlorite, a 1:100 dilution will yield 0.05% or 500 parts per million available chlorine
Contact time for different uses: <ul style="list-style-type: none"> • Disinfection for wiping of nonporous surfaces • Disinfection by immersion of items Surfaces must be cleaned of organic materials, such as secretions, mucus, vomitus, feces, blood or other body fluids prior to disinfection or immersion	<ul style="list-style-type: none"> • A contact time of ≥ 10 minutes is recommended. • A contact time of 30 minutes is recommended

1: Clorox contains 6% sodium hypochlorite and Zonrox 5.25%. Clorox may be diluted 1:120

ANNEX 7: EQUIPMENT LIST FOR ISOLATION ROOMS AND WARDS

- Signage for rooms and/or wards
- Stocks of PPE
- Stocks of hand hygiene
- Stocks of linen
- Trolley to hold PPE outside isolation room
- Sharps containers
- Linen bag for isolation room
- Garbage containers for isolation room
- Container for collection of reusable eye shields, etc.
- Stethoscope, blood pressure cuff, sphygmomanometer, thermometer, blood sample bottles, specimen bottles, intravenous giving sets, intravenous fluids, plaster, tourniquet, lab forms and other necessary items such as needles, syringes, etc.
- Equipment for cleaning and disinfection
- Telephone should also be made available in the ward and isolation room for ease of communication to minimise the need for HCWs to enter isolation rooms
- Stationery

Note: Items brought in to the room should be kept to a minimum

