

---

# CHAPTER 4

## Night fishing methods using lights

- A. Net fishing with lights
- B. Small-scale bouke-ami stick-held dip net fishing
- C. Small-scale basnig lift net fishing
- D. Gillnetting with lights
- E. Offshore handlining and jigging with lights

The night fishing methods that most Pacific Island artisanal and small-scale commercial fishermen use are: reef gleaning, throw-spear fishing, spearfishing around reef slopes, drift gillnetting, handlining with lights, scooping flyingfish with nets from fast power boats, and cage or pot fishing. Heavy fishing pressure on reef and deep bottomfish species due to overfishing has made it harder for fishermen to return home with consistent catches.

This chapter describes several types of net fishing and handlining methods that fishermen can use as alternatives to the fishing methods that they already practice.

## A. Net fishing with lights

Fishing with nets is a productive fishing method that produces good catches. However, this fishing method is not always favoured by government fisheries departments and fisheries management organisations because net fishing operations can be destructive to the environment as well as be counterproductive to fisheries management strategies. Drift nets that are left in the water for long periods can catch and kill bycatch or non-target species, and run the risk of “ghost fishing”. Ghost fishing refers to fishing gear that is lost or abandoned by fishermen but which continues to catch fish and other marine animals. Sometimes fishermen cut off part of a net if it gets tangled in the propeller or gets caught around a coral head, or the net may break off from a predator attack. To avoid net damage and unnecessary harm to marine life, the nets should be used for short periods and then hauled back in. This way, if any unwanted fish or other marine species gets caught in the net, they will survive and can then be released unharmed.

Three net fishing methods are discussed in this chapter: bouke-ami (stick-held dip net fishing), basnig lift net fishing, and gillnetting with lights. Bouke-ami has been adopted from Japan and basnig comes from the Philippines. Gillnetting has always been one of most common net methods used in the Pacific Islands region.

The basnig lift net has not been used much in the Pacific Islands but has the potential to catch fish species similar to those caught by bouke-ami.

Bouke-ami baitfishing is done in countries where there is a skipjack pole-and-line fishery. It's carried out on vessels 18 m (59 ft) or more in length and is not commonly used by artisanal fishermen on smaller boats. However, a down-sized version of this method has the potential to provide artisanal fishermen with the means to supply live bait for pole-and-line fishermen, or whole fish for commercial sales, domestic consumption and value-added products. Basnig lift net fishing can achieve the same goals.

Gillnetting is the most common type of net fishing done in the Pacific Islands. This method is mainly carried out by deploying drifting gill nets, or by encircling fish schools. This chapter highlights other ways of using gill nets with lights to attract fish. The size of the target species that can be caught depends on the net's mesh size. Typical target species include flyingfish, sardinella, scads, garfish and herrings.



## B. Small-scale bouke-ami stick-held dip net fishing

Various types of nets and techniques can be used for bouke-ami net fishing. The mesh can be very small so as to catch tiny baitfish, or large enough to catch sardines, sardinella, scads, garfish and herrings.

The bouke-ami method described in the following paragraphs is a down-sized version adapted for use on small boats around 10–12 m (33–39 ft) long.

There are four stages to bouke-ami: selecting the baiting ground and anchoring the vessel, aggregating, clustering and entrapping fish. Fishermen should have a reasonable knowledge of each stage of the operation, and should work as a team to effectively entrap the target species.

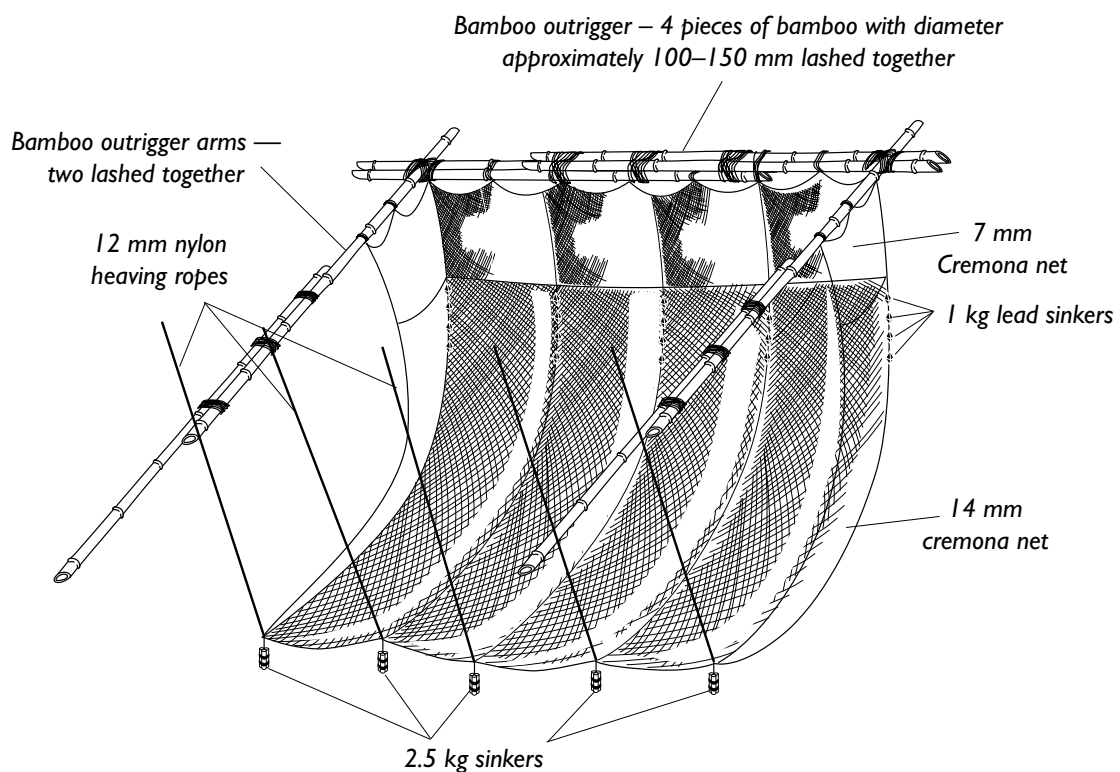

Bouke-ami gear consists of:

- One full-length outrigger float about 150 mm (6 in) in diameter; preferably the same length of the net boat or slightly longer (reinforced PVC, fibreglass, etc); or at least four lengths of bamboo that are three-quarters of the length of the boat and about 100–150 mm (4–6 in) in diameter.

**Note:** The smaller the net, the more skilled and experienced the fishing crew must be in order to trap fish. There are more chances of catching fish with bigger nets using this method than with smaller nets.

- Two to four extension poles, with each pole at least three-quarters of the length of the boat (bamboo, reinforced PVC, fibreglass).
- Four to six 2–5 kg (4–11 lb) lead sinkers.
- At least two 100–500 W overhead lights.
- One 50 W red lamp on an extension pole.
- Underwater light(s), one or more at 100–500 W

The length of the net is 1 ½ times the boat length and the width of the net is the same length as the boat. The width of the net runs parallel with the side of the boat. In other words, 9 m (29.5 ft) by 13.5 m (44.3 ft) for a 9-m (29.5 ft) vessel, or 12 m (39.4 ft) by 18 m (59 ft) for a 12-m (39.4 ft) vessel.

## Selecting the right fishing grounds for bouke-ami

Selecting the right fishing grounds for bouke-ami fishing largely depends on the target species, although ideally, six environmental criteria are needed:

- A reasonably sheltered lagoon that is calm and not exposed to medium to high swells.
- The depth of the fishing ground should be equivalent to or slightly shallower than the net depth
- A flat substrate (composed of sand, shingle, or mud) that is clear of obstacles (in order to avoid snagging the net).
- No currents from rivers, streams or passages.
- Minimum tidal effects during the turn of the tide.
- A nearby underwater pinnacle. It has been found that schools of pelagic fish are found in areas with underwater pinnacles, which is also where baitfish aggregate.

## Anchoring

When underwater lights are used in addition to overhead lights, it is best to anchor the boat up-current from an underwater pinnacle. The underwater light should stream behind the vessel's stern, and float directly over the pinnacle. The net should be positioned so that it does not become snagged on the pinnacle. Fish can later be drawn from the pinnacle to the net boat..

The fishing boat is anchored so that it is pointed into the wind. Before netting begins, the anchor should be transferred amidships so that the boat lies abeam to the resultant force of the current and wind. This will be elaborated on later in this chapter.



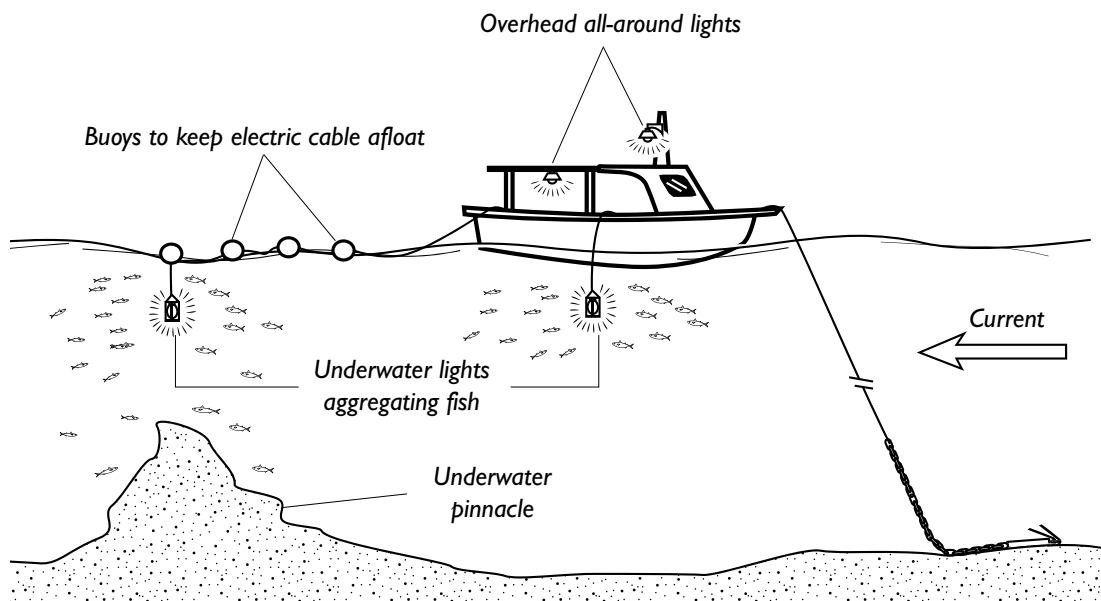

When using only overhead lights, it is best to anchor as close to the pinnacle as possible but where the net cannot become snagged. One or two of the overhead lights should then be focused in the direction of the pinnacle in order to draw baitfish toward the vessel, and the other lights should be focused directly on the water surface beside the vessel.

Upon initially anchoring in the fishing ground, the lights, lengths of bamboo and net should be in position and ready to set. All net lashings except three (forward, centre and aft) should be released and the extension bamboos laid athwartship on the forward and aft decks ready to be connected as extensions to push the net farther away from the vessel.

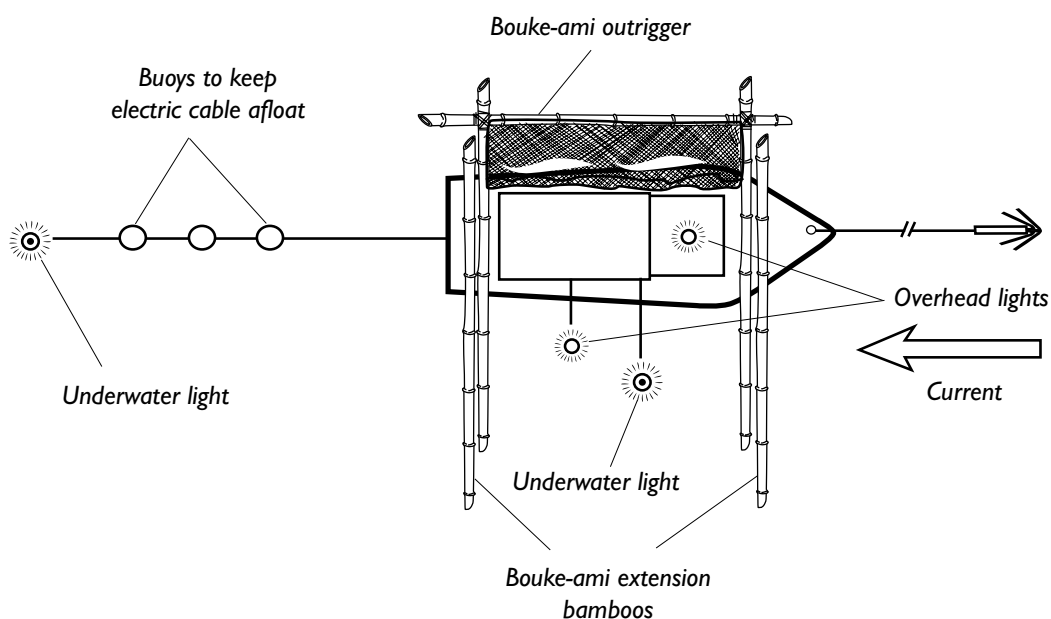

Using only one boat for the operation can be very restrictive so if possible, two boats should be used; one boat to carry the crew and main lighting gear, and the other boat to carry the net and serve as the main platform for netting operations.

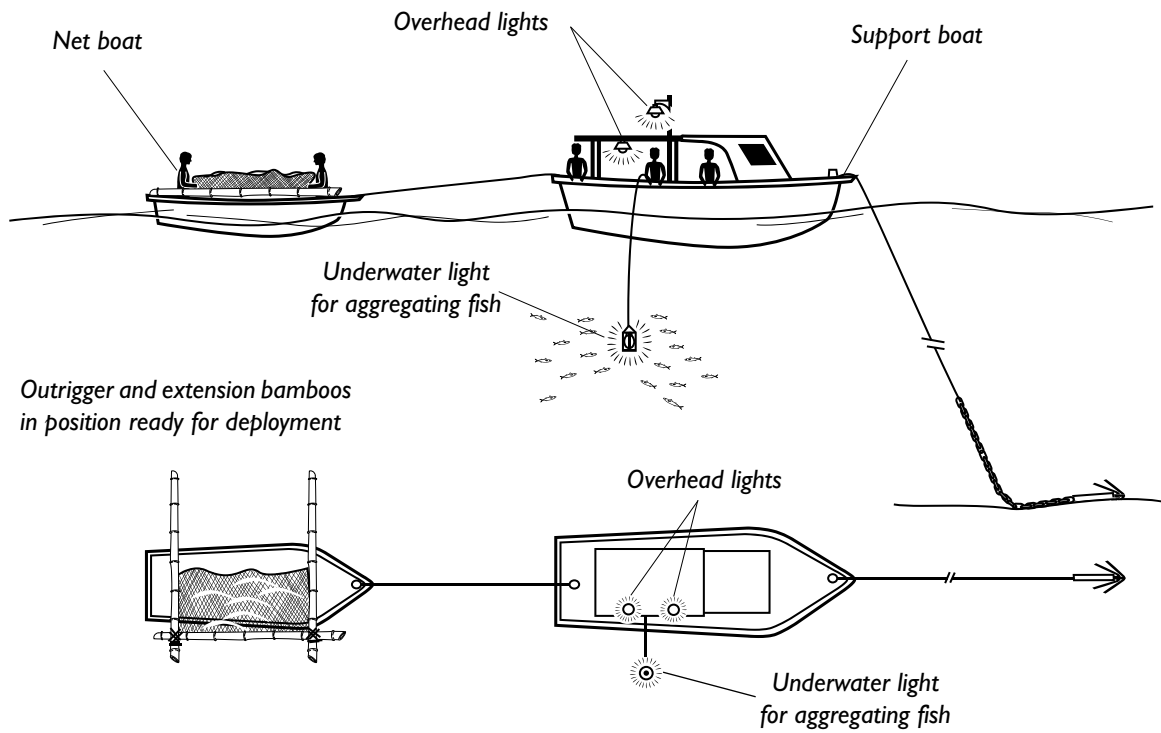

## Aggregating and clustering fish

There are many ways to use lights to aggregate fish. Getting fish to aggregate can be done in a shorter period of time if many bright lights are used. However, due to costs, small commercial fishing operations may only use two to four lamps. The type of lights that are used (fuel, battery or electrical) depends on the vessel and the available equipment. Electrical lights are preferred, but they are costly, and so small boat operators tend to use fuel and battery-powered lamps, which are the focus of this chapter.

Bright surface lights and underwater lights that are 100–1500 W or more are used in large-scale night fishing operations. Small-scale operations typically use lights that are around 100–200 W, and powered by a battery source. Small-scale fishing boats tend to have only one or two 100 amp/hour lead acid batteries on board. As a result, battery-powered underwater lights will likely not illuminate as large an area as electrically powered underwater lights. Underwater lights are usually suspended between 0.5 m and 3 m (1.6 ft to 9.8 ft) below the surface, depending on the fishing ground depth, target species and water clarity.

Lights are normally turned on around sunset with the underwater lights trailing aft of the boat, and the overhead lights positioned where they are most visible. All lights are left on until sufficient numbers of baitfish have aggregated. In areas where a running current affects netting operations, fishermen usually wait until the peak of high tide or the lowest point of low tide to set and haul nets. During these times, there is usually a 10- to 15-minute window of opportunity when the current slows down so that it is easier to haul in the net.

In order to cluster the fish into one tight group, all but one light must be turned off so that the fish circle directly beneath the single lamp. A dimmer switch connected to the lighting system will greatly help to concentrate the fish into a smaller and more manageable group.

The following paragraphs describe two lighting systems that are sufficient for use with bouke-ami lift net fishing.

## Bouke-ami with three bright overhead lamps

Three overhead lamps should be positioned on the vessel where they can be easily turned off, or connected to a switch in an accessible position.

If a pinnacle is close by then, one of the three lamps should be beamed toward the pinnacle (preferably the top most aft light), one should be directed midway between the pinnacle and the vessel, and the third should be beamed onto the sea surface beside the vessel. If there is no pinnacle nearby, the same light positions can be used except that the two top lights (one higher than the other) should be all-around white lights while the third light should have a lamp shade directing its beam to the side of the vessel. Some fishermen prefer to position the lights as high as possible; then when sufficient fish have aggregated, the lights are gradually lowered until they are at bulwark level on the netting side of the vessel.

There are many other variations in using overhead lights to attract fish. These depend on a fisherman's experience with a particular target species and knowing what formation attracts the target species better.

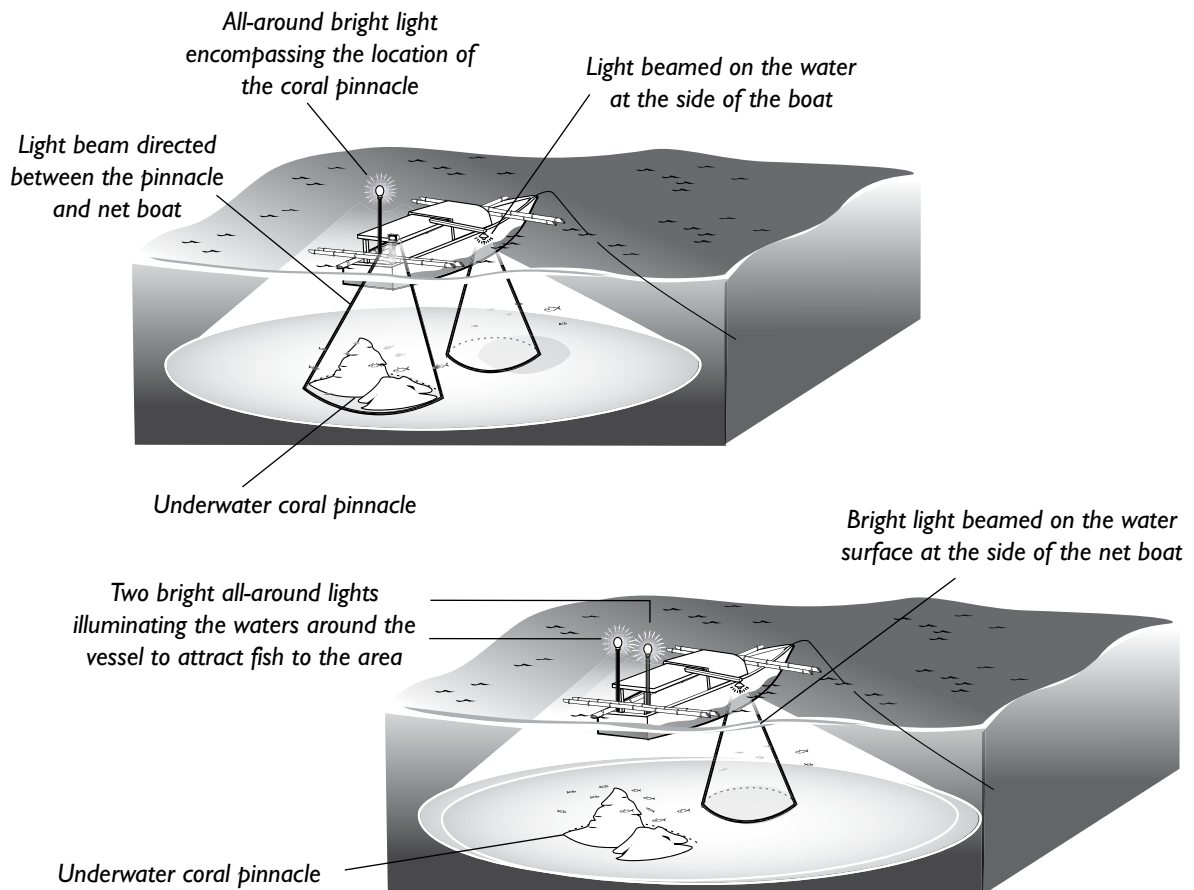

Below are the procedures for carrying out bouke-ami using three bright overhead lamps.

- Relocate the top most all-around overhead lamp to the bulwark next to the shaded lamp.
- Give fish time to move in closer and settle into an “orbit” within the beam of the second all-around light, then switch this light off.
- Allow time for the aggregated fish to move within the beam of the relocated light and the shaded light. Give fish time to regroup; then turn off the relocated lamp while keeping the shaded lamp focused on the water beside the boat. The shaded lamp should be connected to a dimmer switch and to a long pole that can be extended three-quarters of the way between the boat and the outside bamboo of the bouke-ami lift net.
- Dim the light to three-quarters of its full intensity.
- Wait until the fish have clustered and settled down again, then give the order to set the net.
- Once the net has settled, slowly move the shaded lamp around the stern of the boat and into the centre between the floating bamboo and the side of the boat, all the while keeping an eye on the movement of the clustered fish to ensure that they follow the light into the entrapment area.
- Give the fish sufficient time to re-group around the light on the net side.
- Slowly dim the light to half of its intensity so that the orbiting circle of aggregated fish comes within the area of the bouke-ami net. If a dimmer switch is not available, a red lamp with a lamp shade can be used instead.
- Slowly extend the dimmed light or the red lamp outwards to three-quarters of the distance between the vessel and the outer bouke-ami bamboo.
- Allow time for the fish to settle into a rhythmic circling of the light. If necessary, the light can be dimmed to about one-quarter of its full intensity, although care should be taken not to reduce the light too much otherwise big fish may rush in and attack the fish cluster.
- Give the order to close the net. The net should be closed at a smooth and steady pace to avoid spooking the fish by making any unnecessary sounds.
- After the net has completely closed, draw the forward and aft ends together and prepare to scoop the fish into the ice-box or bait tank.





Anchor rope secured at bow of net boat. Two all-around mast lights (A and B) and a side light (C) turned on to aggregate fish

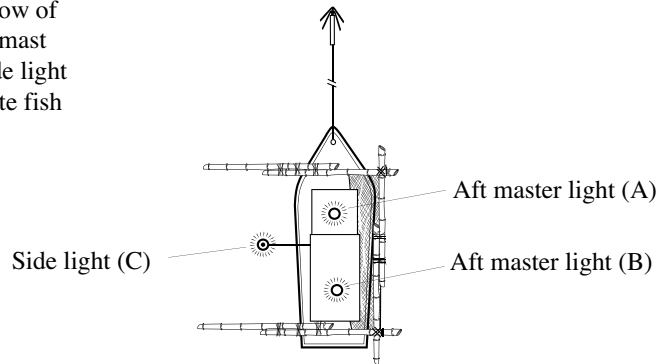

**Commencement of netting operations**

1. Anchor rope shifted amidships

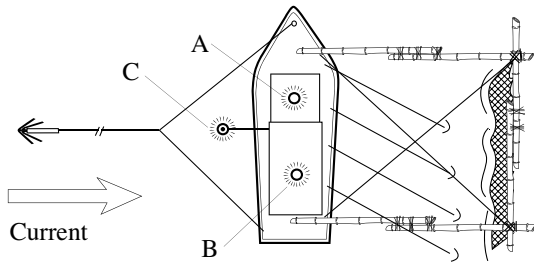

2. B turned off and A shifted to port side

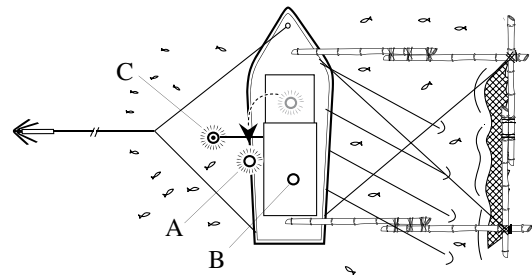

3. Only C turned on

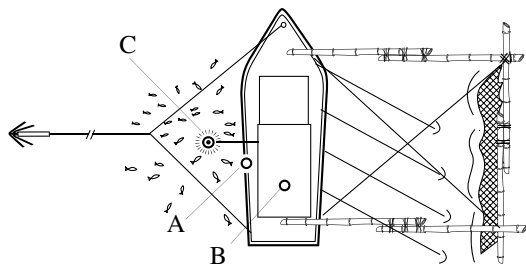

4. C dimmed and slowly moved to centre of net drawing aggregated baitfish

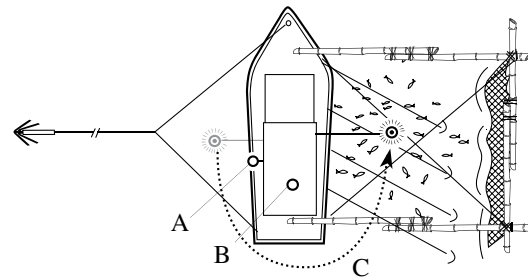

5. Net closed after fish has resettled under the light

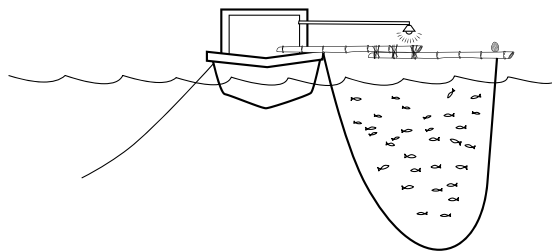

## Bouke-ami with two bright overhead lamps and an underwater light

Position an all-around white light as high as possible on the vessel where it can best be seen. The second light should be a shaded lamp with its beam directed at the sea surface on the side of the vessel opposite to where the netting will be carried out. The underwater light should be streamed behind the vessel, preferably above an underwater pinnacle.

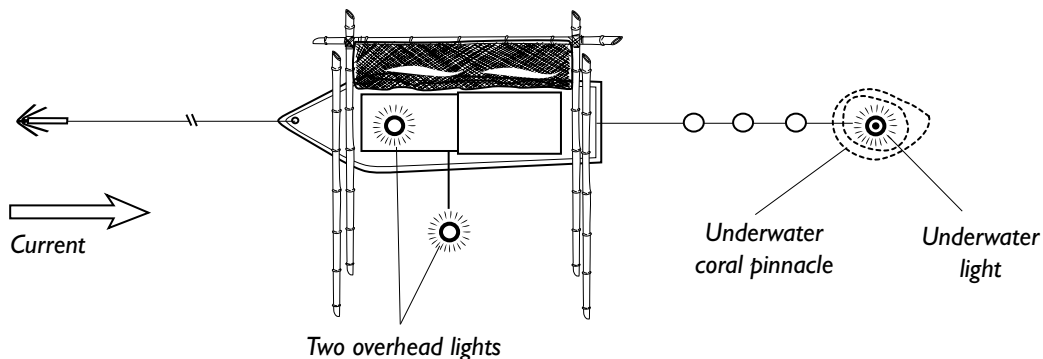
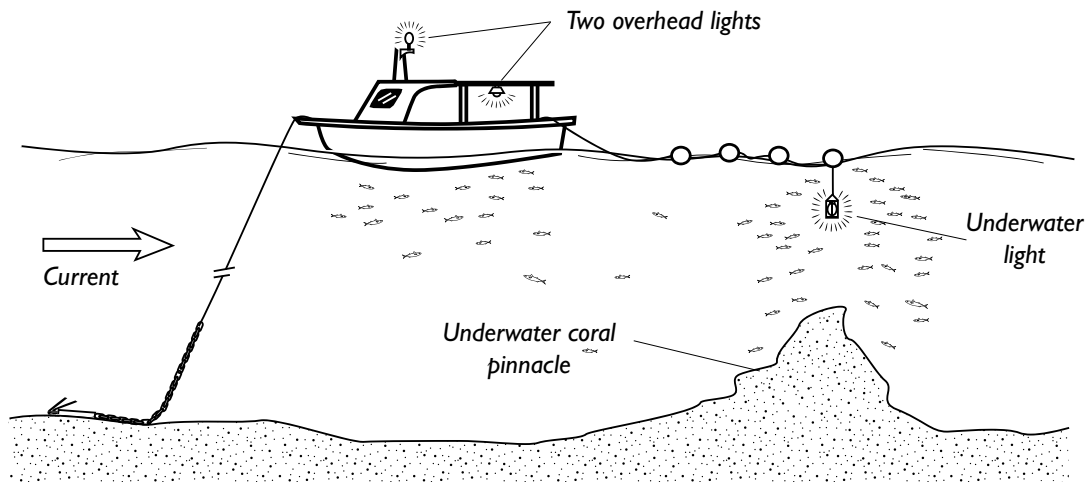

Below are the procedures for carrying out bouke-ami using two bright overhead lamps and one underwater light.

- Draw the underwater light closer to the stern of the vessel.
- Relocate the topmost all-around light to bulwark level and allow the fish school time to settle into an orbit around the beam of the repositioned light.
- Turn off the all-around light and give the fish time to settle into an orbit around the remaining lamp and the underwater light.
- Move the underwater light to the side of the vessel opposite the net and turn off the remaining overhead lamp.

- Slowly dim the underwater light to three-quarters of its full intensity. Looking at the surface of the water and through a portable underwater viewing scope ensure that the fish school has gradually settled into an orbiting circle with no aggravation from bigger fish. Dim the light again to about half of its full intensity so that the outer perimeter of the orbiting fish has closed enough for net setting.
- If a dimmer switch is not connected to the system, then slowly draw the underwater light close to the vessel, giving the fish time to form into another orbit. Turn on a red overhead shaded lamp and turn off the underwater light.
- Give the school time to get back into an orbit again.
- Give the order to set the net.
- Once the net has settled, lift the underwater light to about 0.5–1.0 m (1.6–3.3 ft) beneath the sea surface, then dim the lights again to about one-quarter of their full intensity or just enough so that the orbiting fish are drawn closer but not too close to engulf the light and cause a blackout
- Slowly manoeuvre the light so that it is three-quarters of the distance between the vessel and the outer bamboo of the bouke-ami (do this for both the red lamp and the underwater light).
- Allow time for the fish to settle into a rhythmic orbit.
- Give the order to close the net. The net should be closed at a smooth and steady pace to avoid spooking the fish by making any unnecessary sounds.
- After the net has completely closed, draw the forward and aft ends together and prepare to scoop the fish into the ice-box or bait tank.



Anchor rope secured at bow of net boat.

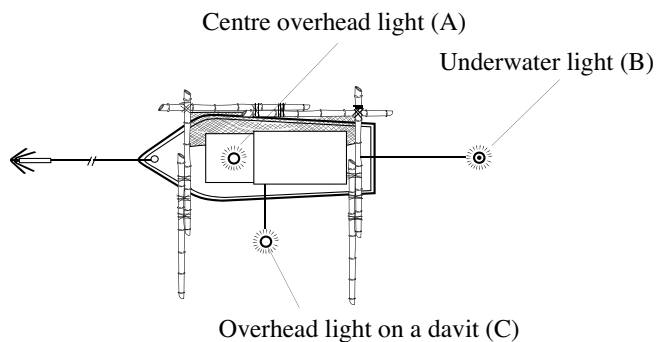

Commencement of netting operations

1. Anchor rope shifted amidships; B pulled in; A moved to the side

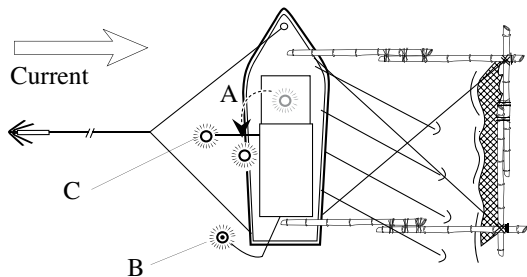

2. A turned off; C and B dimmed

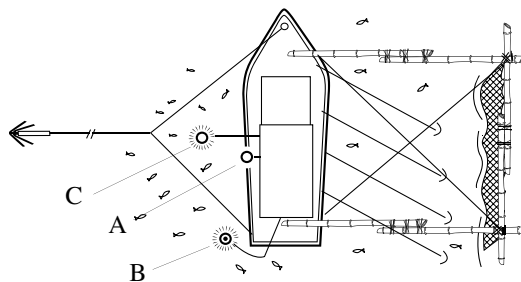

3. C turned off; B dimmed further

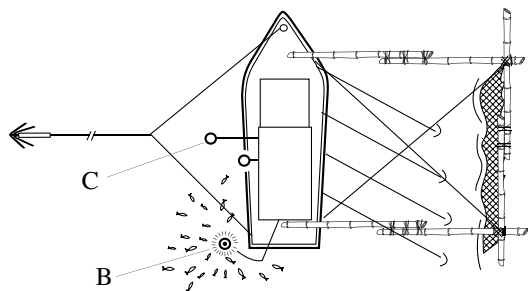

4. B slowly drawn into the centre of the net

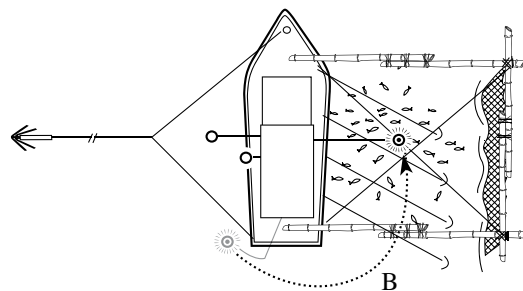

5. Net closed after fish has resettled under the light

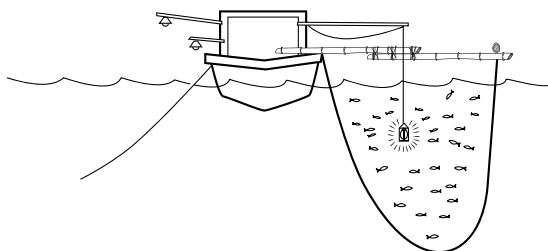

## Net setting procedures

- Before carrying out bouke-ami, the boat must be positioned broadside to the current. To do this, the anchor rope must be relocated from the bow and be secured amidships. If there is no Samson post amidships to tie the anchor rope to, the anchor rope can be bridle-hitched and connected fore and aft.
- Shifting the anchor rope amidships will cause the current to act squarely on the belly of the net so that when the net is hauled in, the anchor rope can be eased off, which makes it easier for the crew to haul the net in.
- Unfurl the net while pushing the bamboo frame out onto the water's surface and adjust spring ropes so that the frame maintains its rectangular shape.
- Push on the fore and aft bamboos to set the net outrigger away from and parallel to the vessel.
- Simultaneously pay out slack on the net so that it does not bind the outrigger as it is pushed away from the boat.
- Simultaneously maintain a slight tension on the forward and aft spring ropes so that the bamboo frames maintain a rectangular shape as the net is paid out.
- Connect extension bamboos at the end of the first length.
- When the outrigger has reached an appropriate distance away from the vessel, tie off the spring ropes.
- Release the sinker edge of the net and pay out hauling lines quickly so that the bottom edge of the net sinks to the sea bottom quickly.
- Maintain vigilance on the spring ropes as the current may catch the net in its drift while the vessel is swung into position by the force of the current acting on the net.
- After the net has settled wait for the order to haul.

## Net hauling procedures

- When the order is given, the net should be hauled in at a steady pace with a minimum of disruption and noise so as not to spook the fish.
- As the bottom edge of the net is hauled, the extension bamboos should be gradually shortened to maintain a deep vertical belly in the net. Care should be taken not to shorten this too quickly because rapidly closing the outrigger toward the vessel may spook the fish.
- As the distance between the outrigger and the side of the vessel decreases, the crew should close off the sides of the net as soon as possible.
- After the sides have been closed off, the outrigger distance can be reduced at will.
- Simultaneous to all of the above actions, tension should be kept on the spring ropes so that the net closes in a rectangular formation.



- Turn on the amidships shaded lamp overhanging the water.
- The fore and aft ends of the net can then be drawn together to gather the fish school under the light and the fish scooped into the ice box or bait tanks.

## Common problems encountered during bouke-ami operations

### *Net does not close squarely*

This problem mainly occurs when the net is being hauled with a current running parallel to the lie of the vessel, or when the hauling team does not work in coordination when hauling in the net. To avoid this:

- Haul in the net close to, or at the peak of, high tide or at the lowest point of low tide; or
- Anchor the vessel with the anchor rope lying abeam of the vessel and into the current so that the current broaches the net at right angles, swelling the net's belly away from the vessel. The team should then haul in the nets steadily (when the signal is given) while the anchor rope is slacked to keep the net vertical below the main bamboo floater that runs parallel to the vessel.

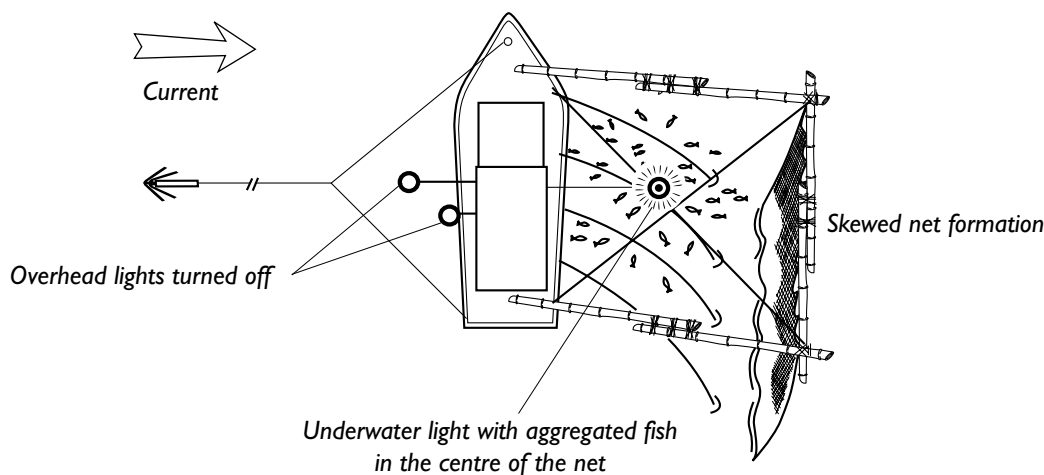

### *Net too heavy to close*

This generally occurs when a strong current bears down at right angles to the net's belly. In order to reduce the force acting on the net when hauling, the anchor rope, which should already be positioned abeam of the vessel, should be eased off slowly in coordination with net heaving. Care should be taken not to slack the rope too fast as two problems can occur: 1) the net's belly may rise up towards the vessel if the formation bamboos are kept rigid, or 2) the net will pass under the vessel's hull if the bamboo formation is reduced while the net is being hauled in.

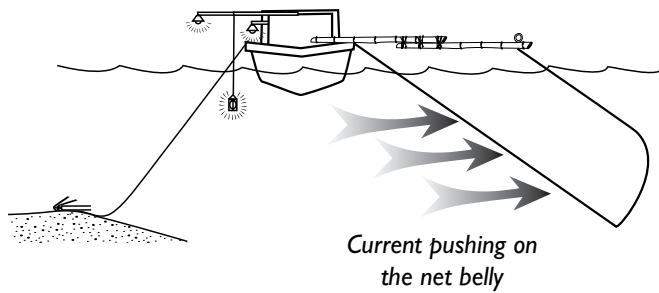

Current pushing on the net belly

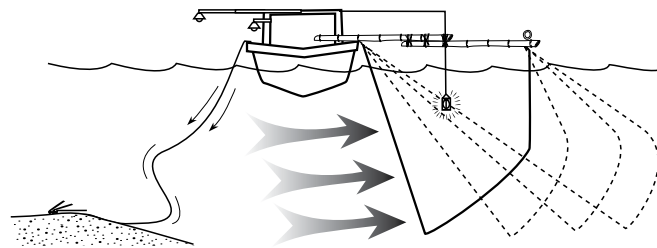

Net belly being reduced at the anchor rope is gently slacked

***Net belly rises up towards the vessel when hauling***

If the anchor rope is slacked too quickly, the vessel will bear down quickly on the net causing the belly to rise and scatter the bait from both ends.

To avoid this, the person(s) responsible for slacking the anchor rope should make sure the angle of the net hauling rope is around 45° to the side of the boat. Ideally, the net should hang vertically downwards parallel to the boat until the deep end of the net is lifted off the bottom.

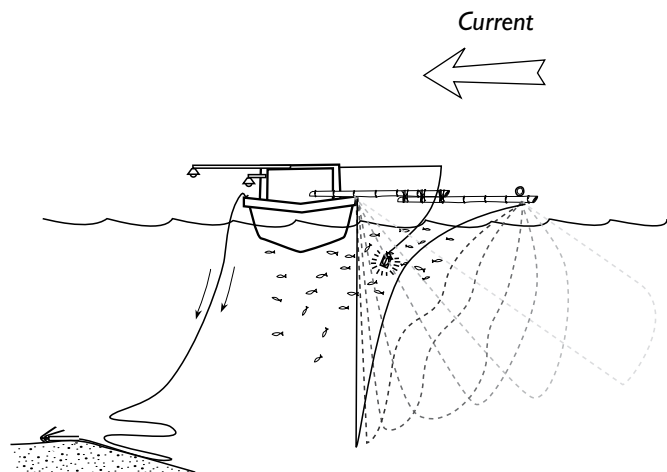

Net belly reducing in size away from the boat then rising towards the boat scattering the bait



## Bait scatters haphazardly while reducing the school cluster diameter or when closing the net

This mainly occurs when the aggregating light connected to the dimmer switch is turned down too quickly or too low. Large predators tend to dart in at this time to attack the aggregated fish. In some circumstances, it is difficult to prevent predators from attacking the target fish regardless of what measures are taken; however, the basic procedures to prevent this from happening are to gradually dim the lights one stage at a time and observe the behaviour of the aggregated fish as their orbiting circle reduces in size. If predators begin to charge in, move the lights back up to the previous stage and, if the cluster does not get disturbed again, begin setting the net.

After the net has settled, lead the aggregated fish into the entrapment area. Then, reduce the light once more, making sure that the fish school orbits in formation. Then, give the order to haul the net in.

The best approach to use for entrapping fish depends on the level of experience of the skipper and his crew.

### C. Small-scale basnig lift net method

Basnig fishing originated in the Philippines and is still primarily a technique used in large-scale fishing efforts to catch offshore pelagic fish such as scads, tunas, mackerels and anchovies. Fishing is normally carried out overnight from early evening to early morning from boats that hold a crew of between 20 and 30 men who pull up a submerged bag net. Gaslights or high-powered electrical lights are used to aggregate fish.

This method is similar to large-scale bouke-ami where lights, big nets and a large crew are required to carry out the operation.

For small-scale operations, the basnig technique was modified to target smaller pelagic species normally caught using bouke-ami. Fishing boats range in length from 7–12 m (23–40 ft). The basnig lift net is down-sized to 10 m (33 ft) on the sides and 6 m (20 ft) in depth. A six-man crew is required.

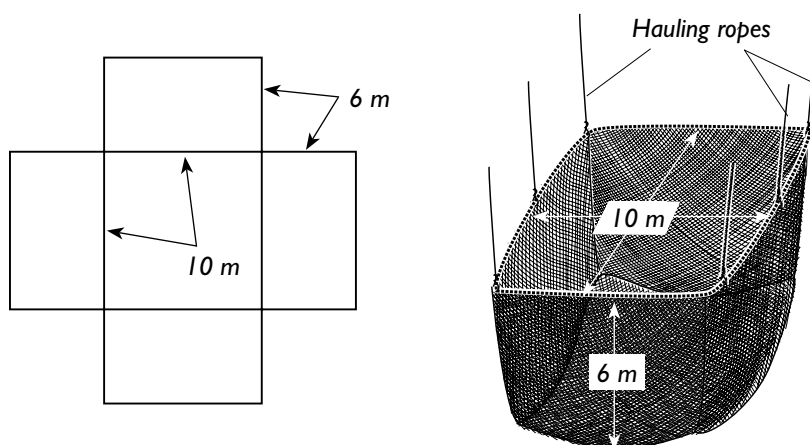



## Positioning the lights

The same positioning of lights for small-scale bouke-ami can be used for small-scale basnig fishing, although some understanding of how the original basnig method works will give fishermen ideas for ways to position lights.

The lights for large-scale fishing operations are positioned on both sides of the vessel from bow to stern. The main rows of fishing lights are directed towards the sea surface with the exception of two or three lights plus the normal ships lights, which can be used as all-around lights. All lights are turned on at sunset.

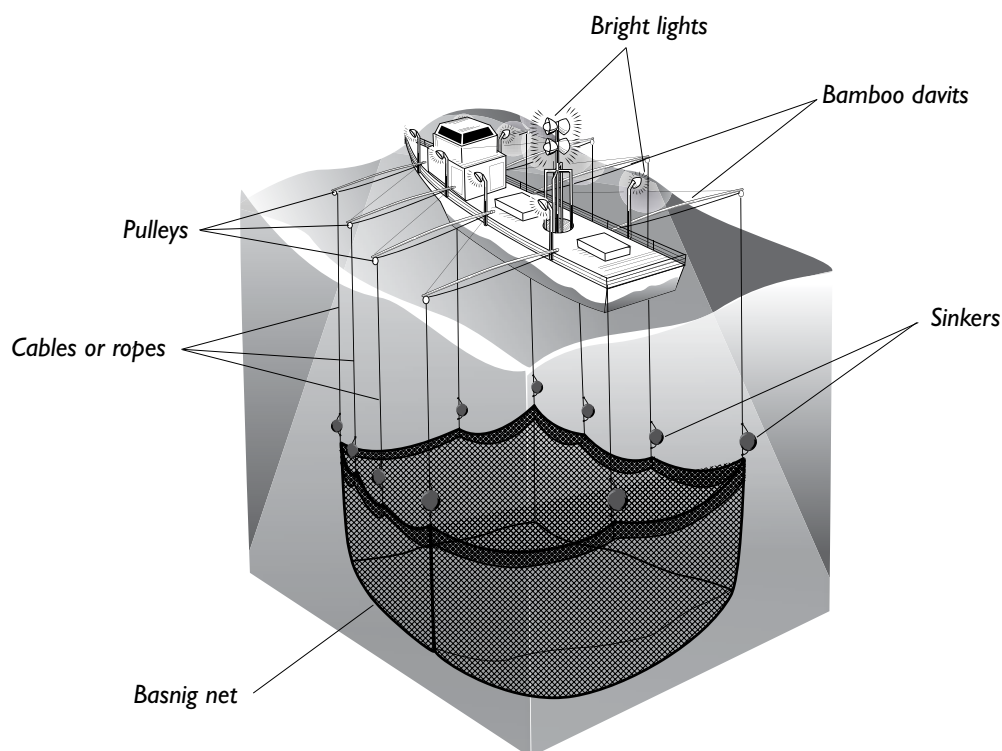

When a sufficient number of fish have aggregated, the lights are turned off gradually one at a time, from the centre lights on both sides to the bow and stern, leaving only the lights at the bow and stern. The net is then set and lowered to a depth based on the observations of the fishing Master, and left to hang while all the lights are gradually turned back on, one at a time, to position the school directly under the vessel again. When the school has settled under the vessel, the lights are again turned off, one at a time, although this time from the bow and stern to the centre until only the centre lights on both sides of the vessel are left on. After checking the fish school again, the order to haul is given.

The same system can be used for small-scale basnig operations if the fishermen have sufficient lights; otherwise, the lighting system for bouke-ami can be used.

## Setting and hauling the basnig net

There are three main methods of setting up the net boat for basnig fishing. If a monohull boat is used, it must be rigged with extended net hauling booms on one or both sides of the vessel. The extension of the booms on either side has to be within the same width as the net.

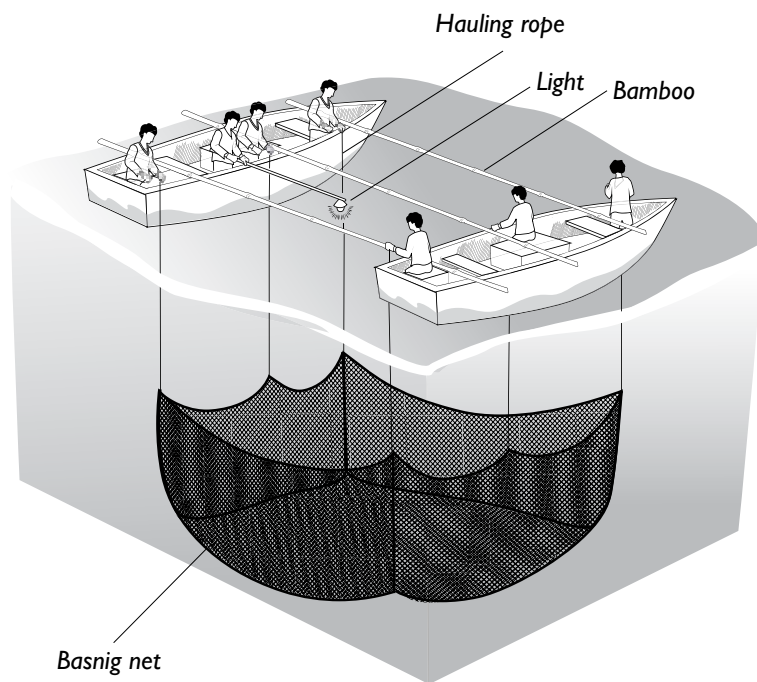
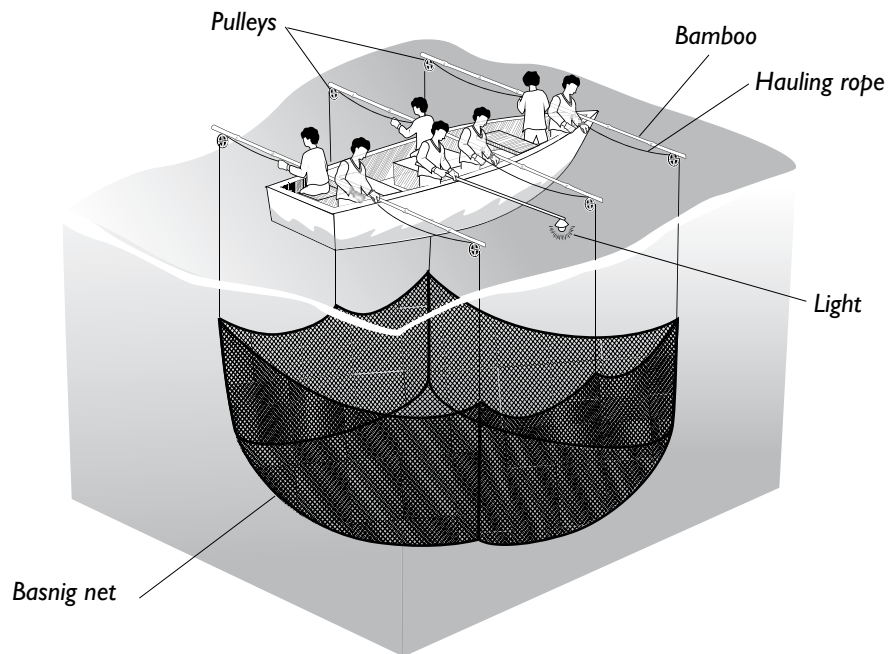

If two boats are used, the hulls can be tied together (like a catamaran) with the gap between the hulls as wide as the width of the net; or, the net boat can have one or two outriggers spaced away on one or each side of the hull to accommodate the width of the net. The outrigger(s) should be strong enough for two or three men to stand on and work from.



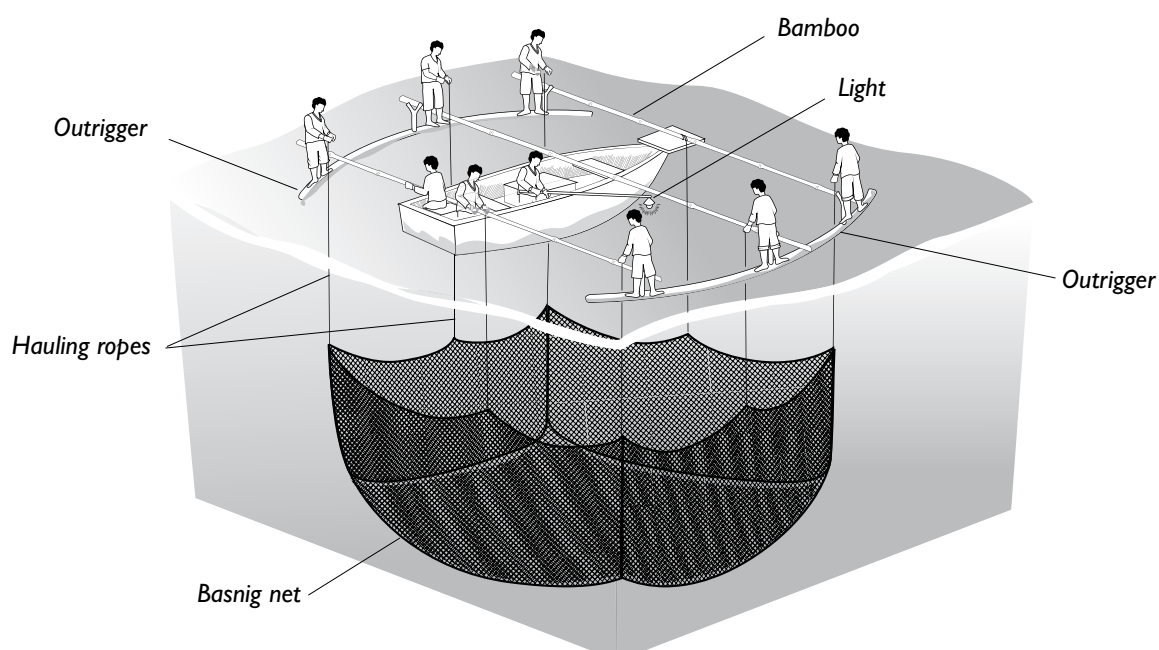

Ideally, just before netting begins, the anchor is pulled up, and the entire operation is carried out while the vessel drifts with the wind and current. Fishing on the ocean side of the reef is done without using anchors. Sometimes a sea anchor is used to control the vessel's drift so that it is in time with the drift of the net. However, if a ground anchor is used instead, then the anchoring procedures and actions taken with the anchor rope during hauling are similar to those used in small-scale bouke-ami.

Immediately before baiting, the anchor rope should be secured amidships. During baiting, if a running current affects net hauling, the anchor rope should be gently eased so that the net is hauled straight up instead of at an angle.

At the point where the light is brought to the stern of the vessel, it should be kept at a distance with a long pole and dimmed to two-thirds of its full intensity while the net is deployed. The net should be stretched across the open space between the main boat and outriggers or catamaran and allowed to sink to the bottom, or to a depth ordered by the fishing Master.

Once the net has settled, the dimmed light should be drawn in gently and positioned over the side of the net boat. This light should again be dimmed to one-third of its full intensity and, based on the judgement of the fishing Master, can be dimmed further to reduce the fishes orbiting range. The same precautions mentioned for bouke-ami apply here as well.

If there is no dimming switch, then a red light with a lamp shade is just as effective. This light should be extended out to the centre between the main net boat and outriggers or catamaran after the net has been set, and after the white light has been extinguished.

When the aggregated fish have settled into a rhythmic orbit within the beam of the dimmed light (or red light), the signal is given to haul in the net. Hauling should be carried out with ease and with as little sound as possible so as not to spook the fish.

Some fishermen prefer to also use fine chum bait in the centre area of the net in order to keep the fish preoccupied while the net is being hauled in.

While hauling, the person(s) in charge of the anchor rope should keep an eye on the net hauling ropes to ensure that they are being pulled up vertically. If the anchor rope needs to be slacked off, it should be done gently and should not allow the vessel to drift off the net.

Once the sides of the net have fully enclosed the fish, the net depth should then be reduced and the outrigger sides of the net should be moved across to the net boat. The fish can then be either scooped out of the net for storage in ice boxes or, if they will be used as live bait, be gently scooped up in buckets and released into the bait tank with fresh circulating water and a dimmed light to get the fish to orbit within the tank.

## D. Gillnetting with lights

The most common way of using gill nets is to set them as anchored or floating nets. These are left out for a period of time and then hauled back in. In some areas, gill nets are set as drifting nets across the path of running fish schools, or they are set to surround running fish schools (similar to purse seining except the bottom of the net is not closed). Gill nets are also used to catch bottomfish, although this chapter only discusses gill net fishing for midwater species such as scads, garfish, flyingfish and mackerel. Gill net mesh sizes range from 50–76 mm (2–3 in) (when the mesh is stretched), depending on which species fishermen are targeting.

Recent innovations, such as using lights with gill nets, are becoming popular in some parts of the Pacific. Instead of using gill nets for passive fishing, they are purposely set and hauled to catch fish aggregated by bright lights at night. The nets are not left out for long periods where the majority of fish get gilled and eventually die before being brought onboard. The nets are spontaneously set to attract fish as they aggregate in sufficient numbers. When brought on board, more than 90% of the catch should still be alive, albeit a bit ruffled from being gilled.

Gill nets should be used responsibly and in accordance with national regulations. They should not be used during spawning aggregations of species vulnerable to being caught by this method.

### Hangin gill net fishing using lights

Fish caught in gill nets are usually kept for domestic consumption or are used as dead bait for larger pelagic fish, but are not kept as live bait unless they are used as soon as they are removed from the net. The lighting system to aggregate fish can be the same as for bouke-ami and basnig fishing, or it can be much simpler by using only two lamps: a bright overhead white light and a red light.

Gillnetting for midwater species can be done in inshore waters or on the ocean side of reefs. When gillnetting in inshore waters, the anchoring position should take into consideration the direction of the current, just as with bouke-ami and basnig fishing.

The same lighting principles are used here. At sunset, the all-around white lights should be turned on. Fish should be given time to aggregate the fish. When a sufficient number of fish have aggregated, a lamp shade is added to one of the white lights to direct the beam to the side of the vessel, or the underwater light dimmed slightly, and the rest of the lights turned off, thus bringing the fish



closer to the boat. Before netting begins, it should be determined if the current is strong. If it is, the anchor rope should be shifted amidship, as in bouke-ami and basnig fishing, otherwise it can be left alone.

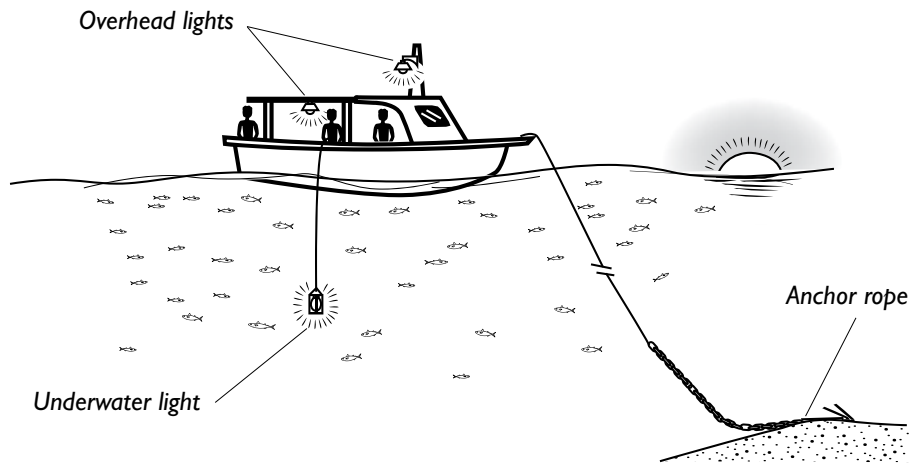

When the fish have aggregated closer to the vessel the net is unfurled and allowed to stretch to its maximum depth. A shaded red lamp is then turned on, or an underwater light is dimmed very low, and the shaded white light turned off.

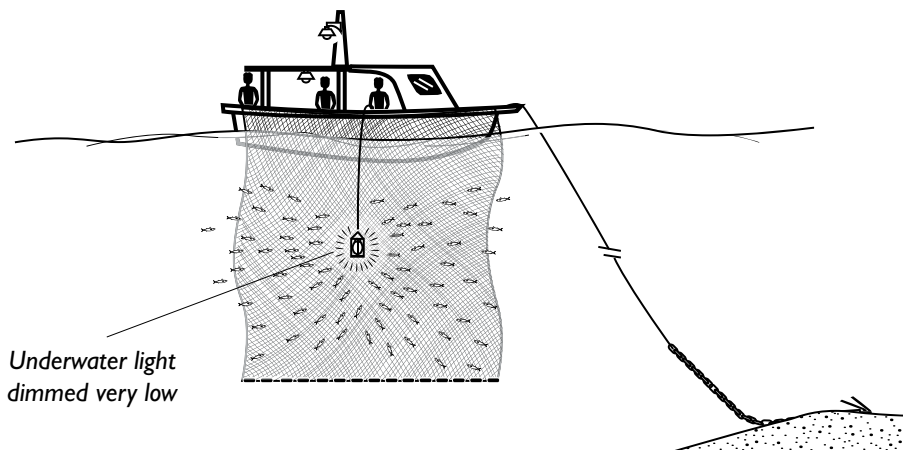
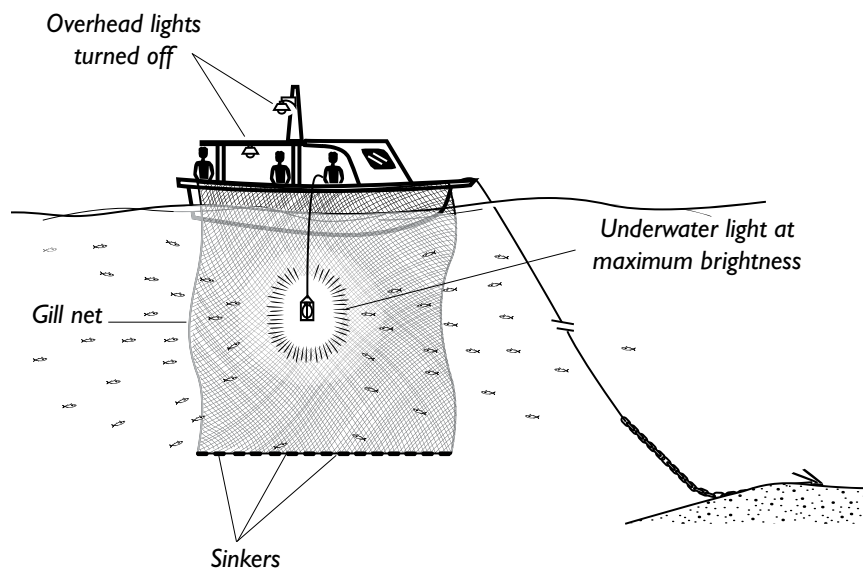

The net is left in the water for about 10–15 minutes before it is hauled in and the gilled fish removed for storage in the ice box. In most instances, after the first haul, larger pelagic fish such as barracuda, Spanish mackerel, trevally and sharks will arrive in a feeding frenzy. The bright white lights are then turned on again and the lamp shade removed to allow the remaining fish to move off into a larger area near the vessel to aggregate once again.

This exercise can go on several times during the night until the required amount of fish is caught or until the net is in danger of being damaged by bigger predator fish. If the current is strong, heavy sinkers can be used to weigh the net down so that it doesn't run with the current and lies at an angle to the surface. The length of time that the net is in the water depends on the experience and observations of the fisherman. It is important not to leave the net in the water for too long, otherwise, larger pelagic fish will attack the gilled fish and damage the net.

It is best to fish in depths that are about the same as the gill net's length; in offshore waters hanging net lengths between 5 m (16 ft) and 15 m (49 ft) are sufficient for catching scads, garfish and flyingfish. A sea anchor must be used in offshore waters with this method.

## Gill nets with lights and sea anchors in offshore waters

In some Pacific Island countries, flyingfish are caught using a fast boat, a bright spotlight and a scoop net on a long handle. As the brightly lit boat speeds through the water it spooks the flyingfish, causing them to flee. When they do this, they often become airborne and this is when they are scooped with a handheld scoop net. This fishing method is effective on moonless nights and requires a boat that is easy to manoeuvre, has sufficient fuel capacity, and a fisherman who is skilled in both handling the boat and scooping the fish at the same time.

A more passive method is setting a drifting gill net at night with lights attached to it. This method catches flyingfish as well as other fish such as scads, mackerel, sardinella, and garfish. In offshore waters, it would be advantageous to use one or more small sea anchors to slow the net's drift in order to keep its rectangular shape. The sea anchor used for this purpose is similar to the one found in life rafts, and is usually made of denim cloth or a strong material that measures 500 mm (20 in) in diameter at the opening, tapering to an apex of 100 mm (4 in). The length is 1,000 mm (39 in).

Below are several ways to use sea anchors and lights with drift nets.

**Method 1:** Connect one sea anchor at the up-current end of the net so that the net lies and drifts with the current. Place a floating light at this end, another light in the centre of the net, and yet another light at the end of the net. Some fishermen position their lights one-quarter of the way in from the sea anchor end, another in the centre, and a third anchor three-quarters of the way from the sea anchor end. Sometimes the net is set this way to allow the loose end of the net to gradually stream down current.



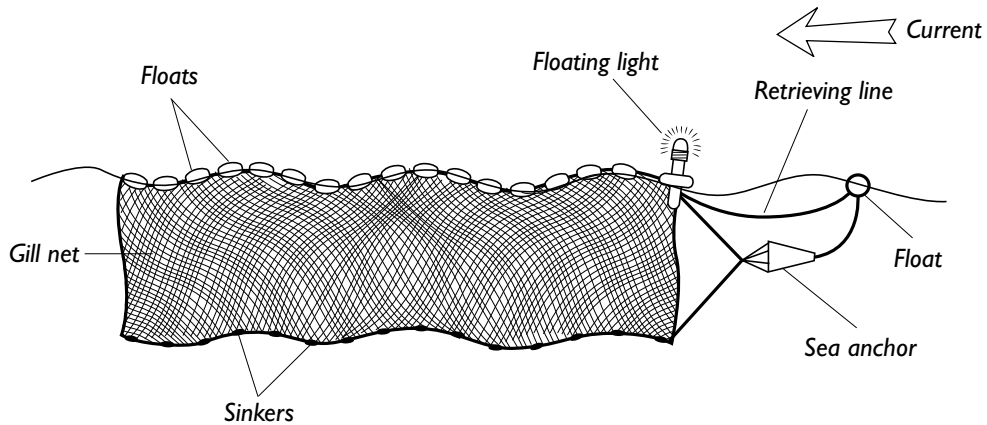

**Method 2:** Connect a sea anchor at both ends of the net so that the net lies across the current. With this set up, the current acts on the centre section of the net, pulling the ends together. It is best to position the lights at both ends and at the centre so that the gap between the end positions can be monitored and the net hauled in before it closes and meets. In most instances, this only happens when the current is strong, otherwise the nets are normally hauled in before any trouble develops.

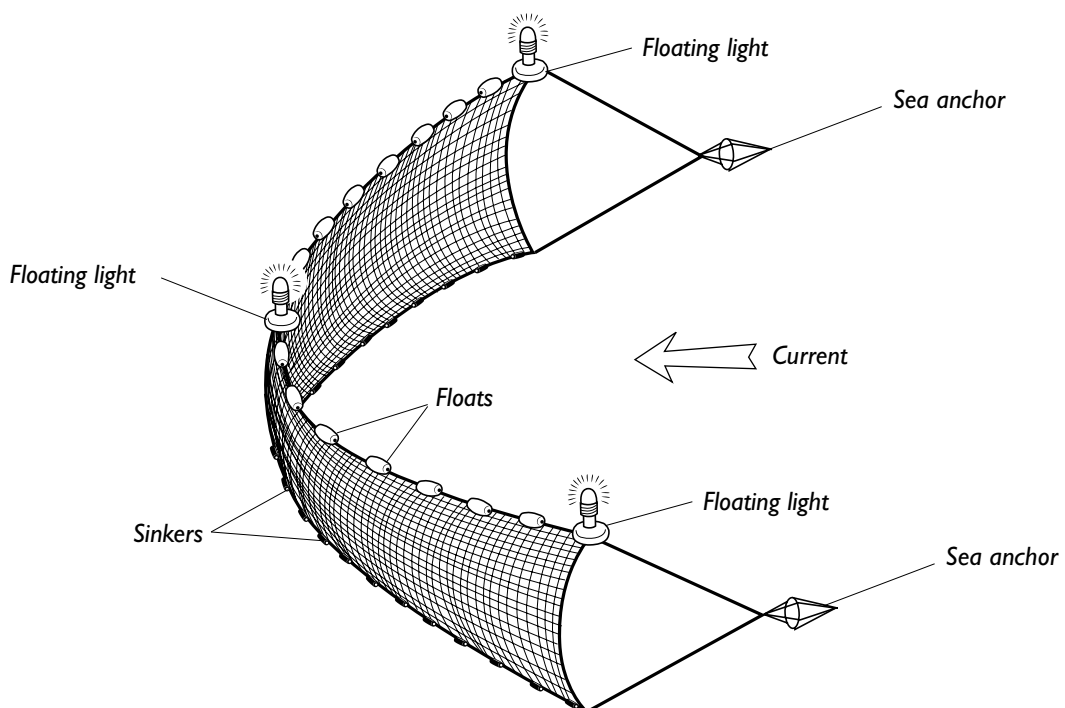

**Method 3:** Connect a sea anchor at both ends of the net and then connect a third sea anchor in the centre. It is best to position a light at both ends of the net and one in the centre to monitor the movement of the net ends.

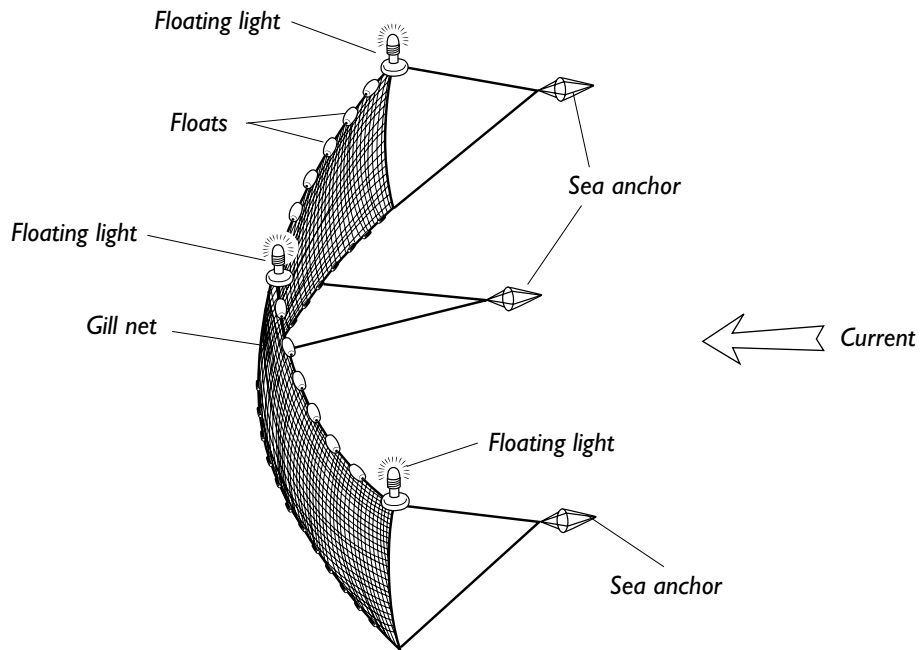

**Note:** In Methods 1–3, after the net has been set, the net boat can drift off while the fishermen engage in other activities or relax for half an hour or so before hauling the net back in. A light should always be kept in the water while this is being done to continue aggregating fish so that after hauling and removing the catch, the boat can move up to the light and reset the net again.

**Method 4:** Tie one end of the net off the bow of the boat and the other end to the mooring line of a sea anchor. Drift along with it with one light at the point where the net is tied to the boat, another light one-third of the net length, and a third light two-thirds of the length of the net from the sea anchor end. The rope frames of the net should be strong enough to take the forces acting on the net. The sea anchor's size should match the boat's length. In most instances this method is carried out in calm weather and very rarely in moderate to rough weather.

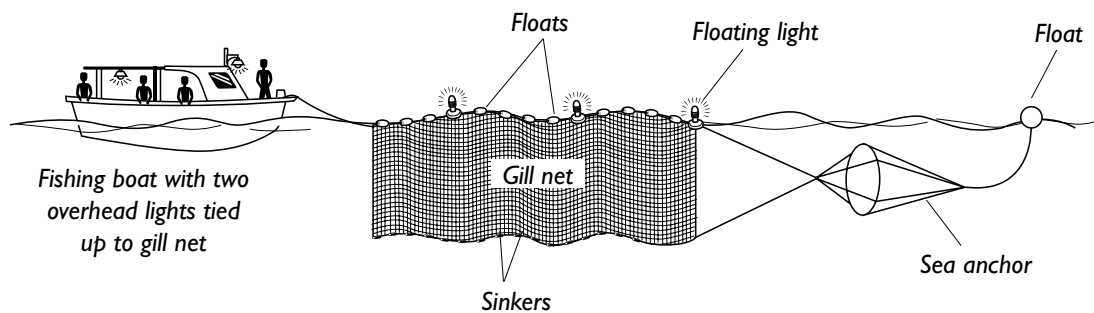



## E. Offshore handlining and jigging with lights

The handlining and jigging methods described in this section are adapted from daylight fishing techniques. Several minor but distinctive changes are made to day fishing gear to make it effective for night fishing.

As with all fishing activities, the fisherman's knowledge of fishing grounds, habits and behaviour of target species, environmental conditions, and the type of fishing method to use are of paramount importance for successful night fishing. In many cases, inexperienced fishermen have tried the right methods but at the wrong time or wrong place, and then concluded that the fishing method didn't work or that there weren't any fish in the area.

This section highlights some of the conditions needed for successful handline fishing and also describes the different types of night handlining methods that are used with lights.

Target species are mainly tuna (bigeye, yellowfin and skipjack), billfish (marlin, sailfish and swordfish), wahoo, barracuda, mackerel, mahimahi, pike, scad, squid and oilfish. Sharks, opah, albacore tuna and pomfret are also caught but they are not typically target species.

### Fishing grounds for offshore handlining

The fisherman's choice of fishing ground for handlining depends on the species of fish he is after, his knowledge of the seasonal occurrence of his target species, and the target species' feeding habits and behaviour. The easiest way to select good fishing grounds is to seek out traditional or experienced local fishermen who can direct you with the point of a finger. But this information may not always be forthcoming. Most fishermen guard their knowledge of good fishing areas with a passion. Therefore, a fisherman needs to have basic knowledge of the sea and the places that will most likely have fish. He needs to 1) know the ideal sea conditions and temperature for fishing; 2) identify areas where eddies and upwelling occur; 3) know the locations of seamounts, underwater spurs, openings and passages through the reefs, and river and creek outlets; and 4) know the direction and strength of ocean currents that run through the fishing ground.

Relating the current to bottom topography, river and creek outlets, and reef passages can also give the fisherman an idea of where an eddy or a localised upwelling may occur. Eddies mainly occur in the lee of seamounts, while a localised upwelling can be found above seamounts or somewhere along the rise of the bottom topography toward an island.

Baitfish aggregate in a tight group just off disturbances such as eddies and upwellings, with bigger fish not far away. If a fisherman finds baitfish, then he has a good chance of finding larger fish nearby. Using live bait is one of the best ways of catching larger pelagic fish.

### Fishing times for offshore handlining

Most fishermen have their own ideas of when it's best to go handlining, but the environmental factors that should be taken into account include the moon phase, ocean current, tide, time of day, water temperature, water clarity and water colour.

In most cases, target species can be caught during the day as well as at night. However, during the day fishermen need to find a way to attract the fish to where they are, chase after fish schools, or fish



randomly in areas that the target fish are known to frequent. The exception to this is fishing near a fish aggregating device (FAD). A FAD acts as an offshore focal point where baitfish aggregate, thus attracting larger pelagic fish.

At night, bright lights on a drifting boat or platform work well to aggregate fish. The bright lights attract tiny marine organisms that in turn attract filter feeders that are fed on by larger pelagic species. The best way to night fish is to position the boat at the fishing ground in the late afternoon when handlining and chumming can be done. Just before dusk, the bright lamps are lit.

The rising and falling tide greatly influences fishing. The ideal time is during a rising tide between late afternoon and midnight. Some fishermen only fish during a rising tide, rest at slack tide, then do another stint of fishing on the morning rising tide. Fish are typically most active from 2200 hours to 2300 hours, before slowing down around midnight. Bigeye tuna, yellowfin tuna, albacore tuna, barracuda and Spanish mackerel are some of the species that can be caught under these conditions. Fish become active again at around 0300 hours until daylight. During slack tide, fish can still be caught but not as easily. There are always exceptions and there are no hard and fast rules about fishing times. The times mentioned here are based on the authors' experience and are meant to be a starting point.

## Night jigging methods

The methods highlighted in this section can be used to catch large pelagic fish as well as baitfish. The size of the target fish will depend on the size and strength of the gear used.

The main features of all night fishing gear are that most have some form of illumination in the rigging to attract fish. These include glow beads, glow tubes, light sticks, reflector tapes, reflector skirts, and miniature lights. The live bait method and the chum bait method depend mainly on the target species' sense of hearing and smell, whereas most baitless jigging methods depend on attracting the fish's visual senses with lures that look like baitfish and are easily seen in the dark.

### *Live baitfish jigging with plastic strip lures and chicken feathers*

One of the best ways to catch large tuna is to use live bait. Baitfish are jigged using 15–30 kg (33–66 lb) test monofilament line and small “J” hooks (size 4/0) with pink or blue plastic strips or chicken feathers attached. Shiny strips and glow beads are added to the lure to reflect light, this making the lures effective for night fishing. Normally, two hooks on separate trunk lines are used. A sinker or underwater light is attached at the connection where the two trunk lines meet the mainline. These artificial lures are lowered to a depth of 20–100 m (66–328 ft) where the mainline is jigged (jerked upward). Baitfish are usually fished for at depths around 20–60 m (66–197 ft) as it gets later into the night.

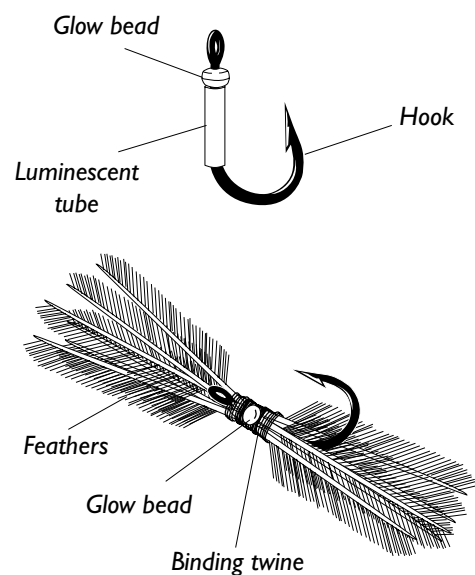

**Sabiki jigs** consist of a trunk line with three to six or more branchlines. Sabiki is a Japanese expression for bait attractant so the rigs are set up to attract and catch baitfish for use as live bait. However, in the Pacific Islands, these small fish are also delicacies that are consumed by the islanders.

An ideal way of using this type of rig for night fishing is to use an underwater fishing light, such as an AA battery-powered light, at the end of the rig instead of a lead sinker, or at the top of the rig with a sinker at the end. Water-activated disposable Micro LED flashing lights can also be used with sinkers.

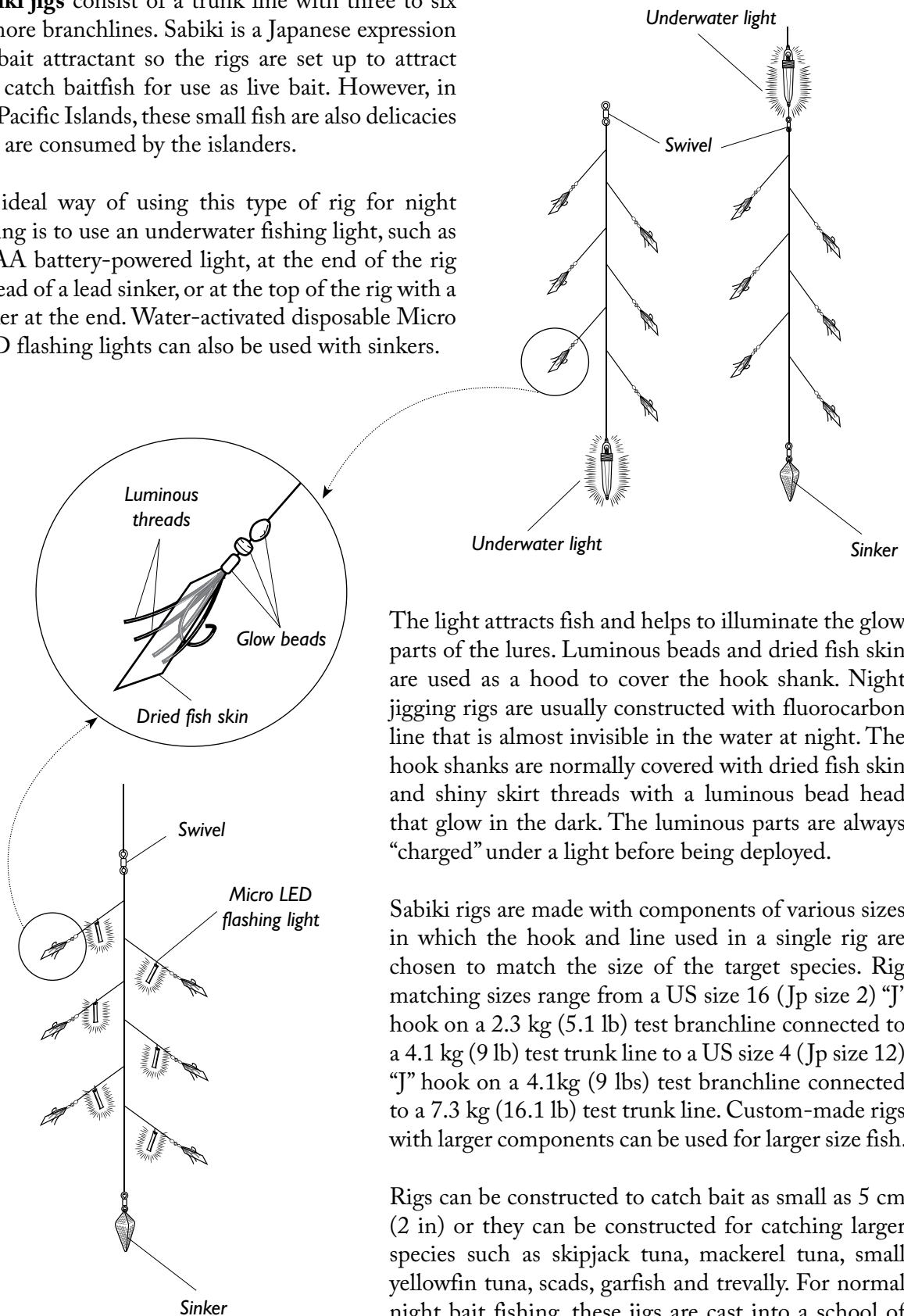

The light attracts fish and helps to illuminate the glow parts of the lures. Luminous beads and dried fish skin are used as a hood to cover the hook shank. Night jigging rigs are usually constructed with fluorocarbon line that is almost invisible in the water at night. The hook shanks are normally covered with dried fish skin and shiny skirt threads with a luminous bead head that glow in the dark. The luminous parts are always “charged” under a light before being deployed.

Sabiki rigs are made with components of various sizes in which the hook and line used in a single rig are chosen to match the size of the target species. Rig matching sizes range from a US size 16 (Jp size 2) “J” hook on a 2.3 kg (5.1 lb) test branchline connected to a 4.1 kg (9 lb) test trunk line to a US size 4 (Jp size 12) “J” hook on a 4.1kg (9 lbs) test branchline connected to a 7.3 kg (16.1 lb) test trunk line. Custom-made rigs with larger components can be used for larger size fish.

Rigs can be constructed to catch bait as small as 5 cm (2 in) or they can be constructed for catching larger species such as skipjack tuna, mackerel tuna, small yellowfin tuna, scads, garfish and trevally. For normal night bait fishing, these jigs are cast into a school of baitfish and slowly retrieved; or they are deployed vertically to a specific depth then jigged back slowly until there is a strike.

**Jigging rod rigs** are mostly used to catch larger fish such as yellowfin or bigeye tunas, oilfish, billfish, skipjack, rainbow runner, frigate mackerel or pomfret. The construction of the lure is not unlike that of a single sabiki lure except that the hook and branchline are bigger. The hook, branchline and mainline sizes are stronger mainly to target larger pelagic fish. When using two hooks to a mainline it is best to have a manual or power-operated reel to haul the fish in, otherwise only one lure is sufficient for handlining.

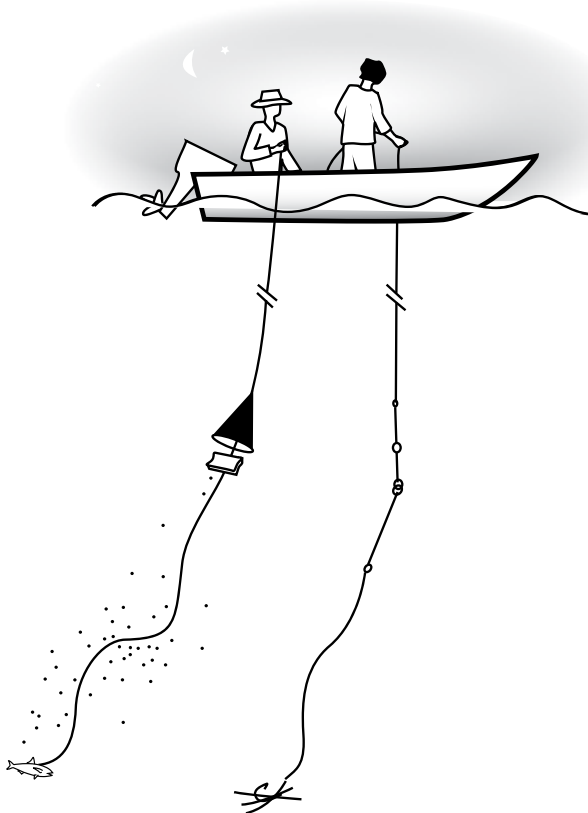
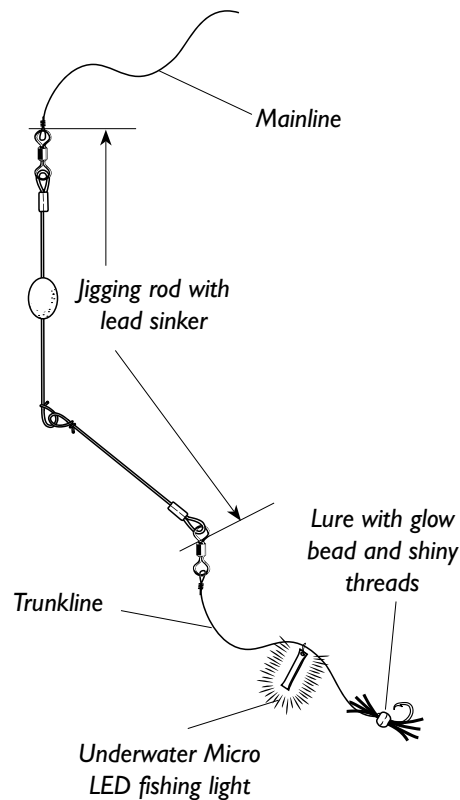

Fishing is normally carried out at depths of around 20–100 m (66–328 ft) depending on the aggregation of baitfish and the time of the night. Just after sunset, deeper depths are fished but as the night progresses and more bait aggregate around the light, jigging is done at shallower depths.

The rod jigging method works well with the chum bag method. The two fishing methods are usually done simultaneously from opposite ends of the boat.

## Chum bag (scatter bait) method

The chum bag, or scatter bait fishing method, is a modification of the traditional drop-stone fishing method used by most offshore mid-water fishermen in the Pacific Islands. It is an improvement on the palu-ahi fishing method, which is the Hawaiian adaptation of the drop-stone method.

The principle behind the drop-stone method is to wrap chum bait and a baited hook to a rock with a leaf. The rock is used as a sinker to take the parcel to the desired depth where the chum is released by tugging on a slip knot used to tie the parcel together. The chum bait floats (scatters) downcurrent to attract fish to the baited hook at the end of the mainline.

The stone sinker then falls loose and sinks, while the baited hook floats free with the scattered chum bait and dangles downcurrent where fish will strike. A new stone and leaf are required for each attempt, which can be limiting if fishing for many hours because it entails having to carry loads of rocks and leaves on every fishing trip.

### *Drop-stone fishing gear*

#### **Preparing the bait parcel**

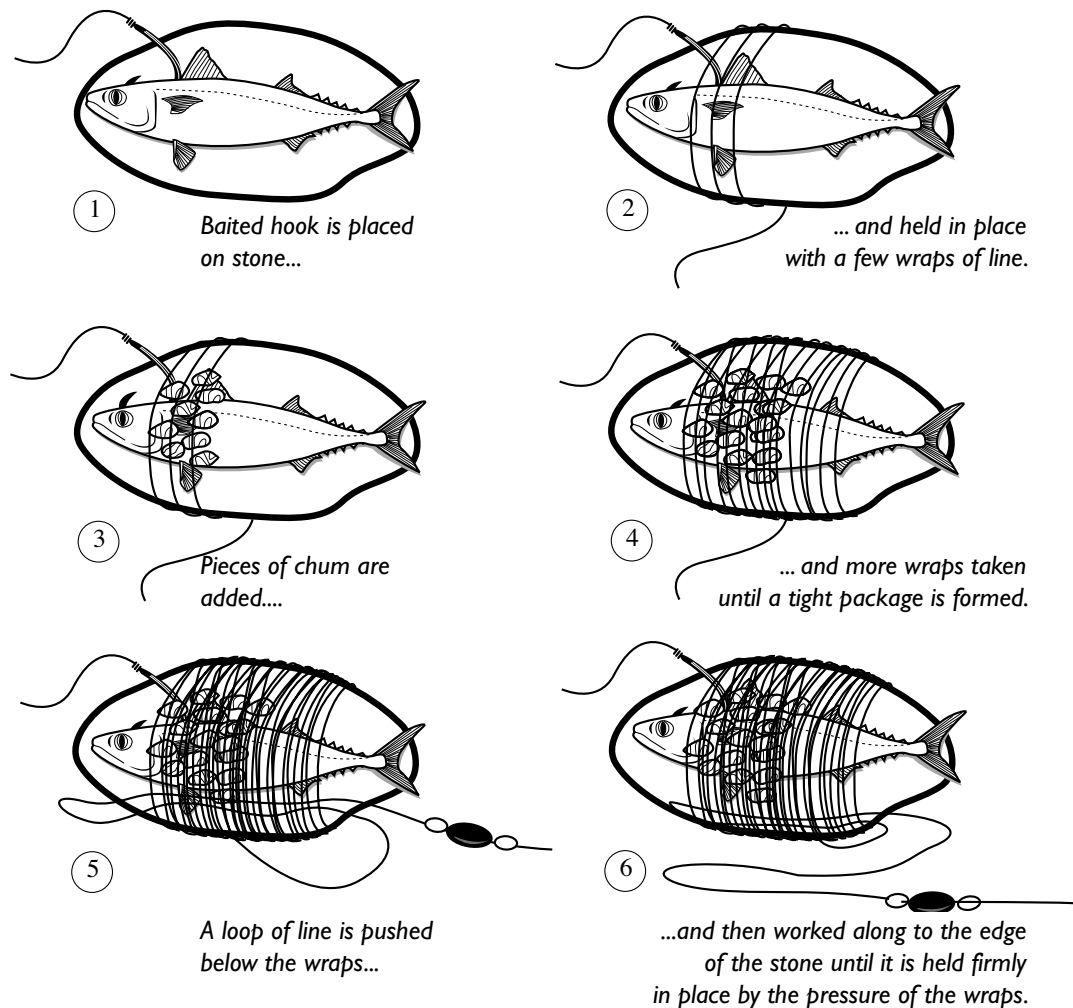

*Palu-ahi fishing gear*

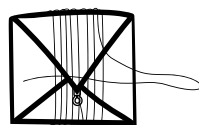
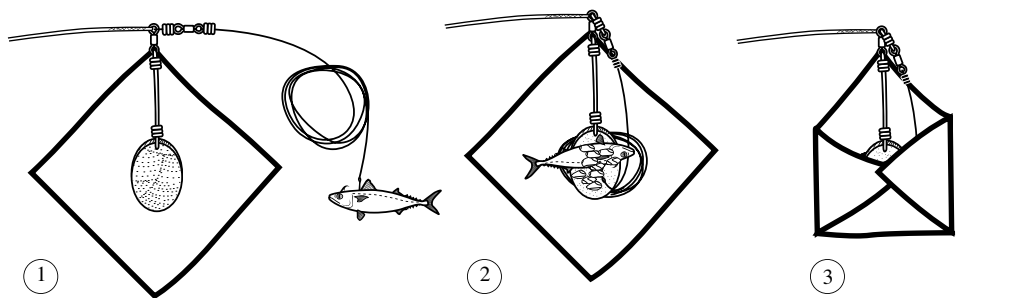
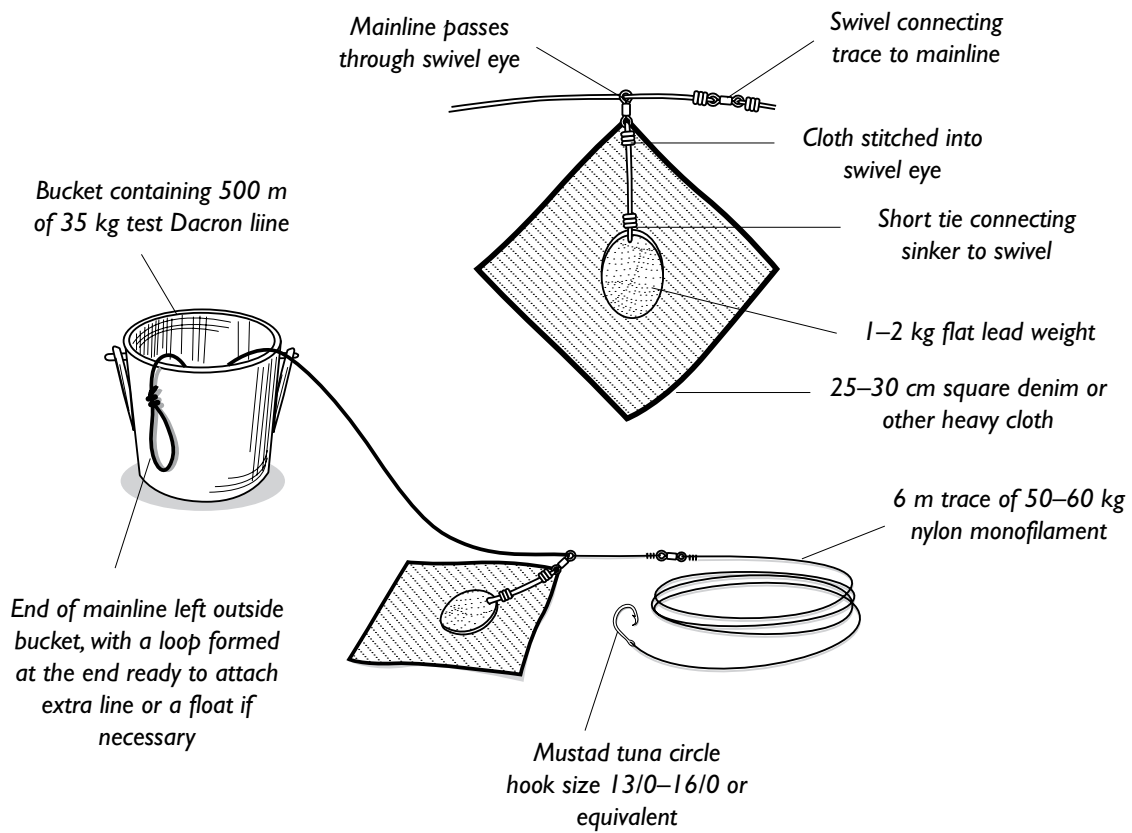

Mainline is wrapped around package several times, then formed into a loop.

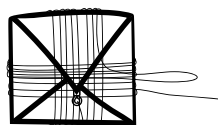

Keeping the loop in place, more wraps are taken at right angles to the first.

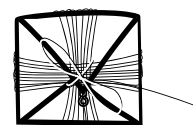

A second loop is made in the mainline and used to tie a slip knot with the first loop.

## Chum bag fishing gear

Modification of the drop-stone fishing method to the chum bag fishing method includes:

- Replacing the leaves with a black cloth cone bag approximately 450 mm (18 in) in length by 200 mm (79 in) in mouth diameter.
- Replacing the stone sinker with a 1 kg (2.2 lb) lead sinker, with a swivel at both ends.
- Coiling the 20 m (66 ft) trunkline on a wooden or hard plastic slat approximately 125 m (410 ft) x 75 mm (3 in) x 12 mm (0.5 in).

This modified gear relieves the fisherman from having to carry large supplies of flat rock and leaves to the fishing ground each trip, and gives the fisherman limitless attempts to attract fish to the fishing area provided he has enough bait. The chum bag also holds more chum depending on the size of the bag used. This method is effective for daylight operations as well and when used during night fishing, pelagic species are drawn to the bright surface and underwater lights as well as the chum bait released using this method.

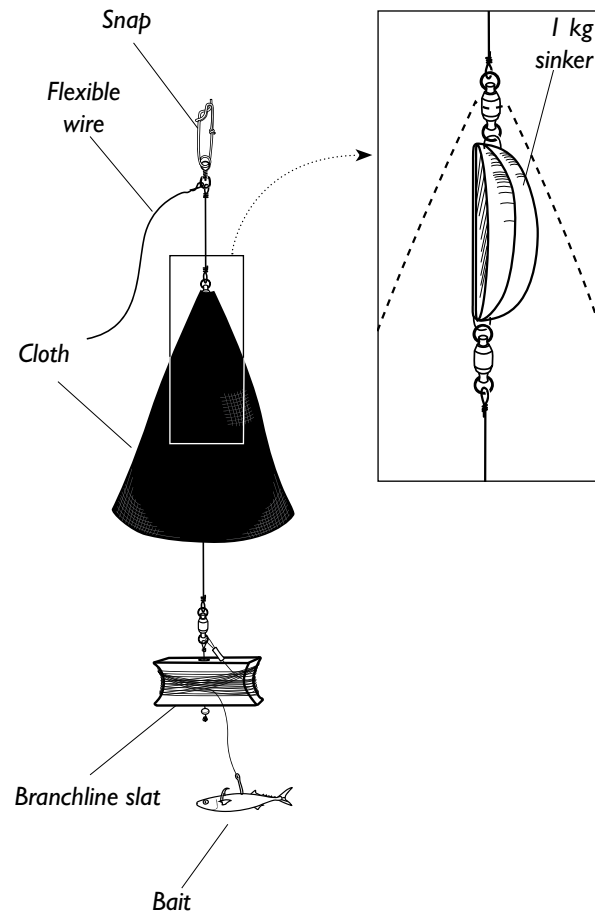

*Fill bag with chum bait*



*Insert baited hook and branchline slat*



*Close off chum bag mouth with a flexible wire attached to snap*



### Chum bag fishing operation

