

Vertical Longlining
and other
Methods of Fishing
around
Fish Aggregating Devices
(FADs)

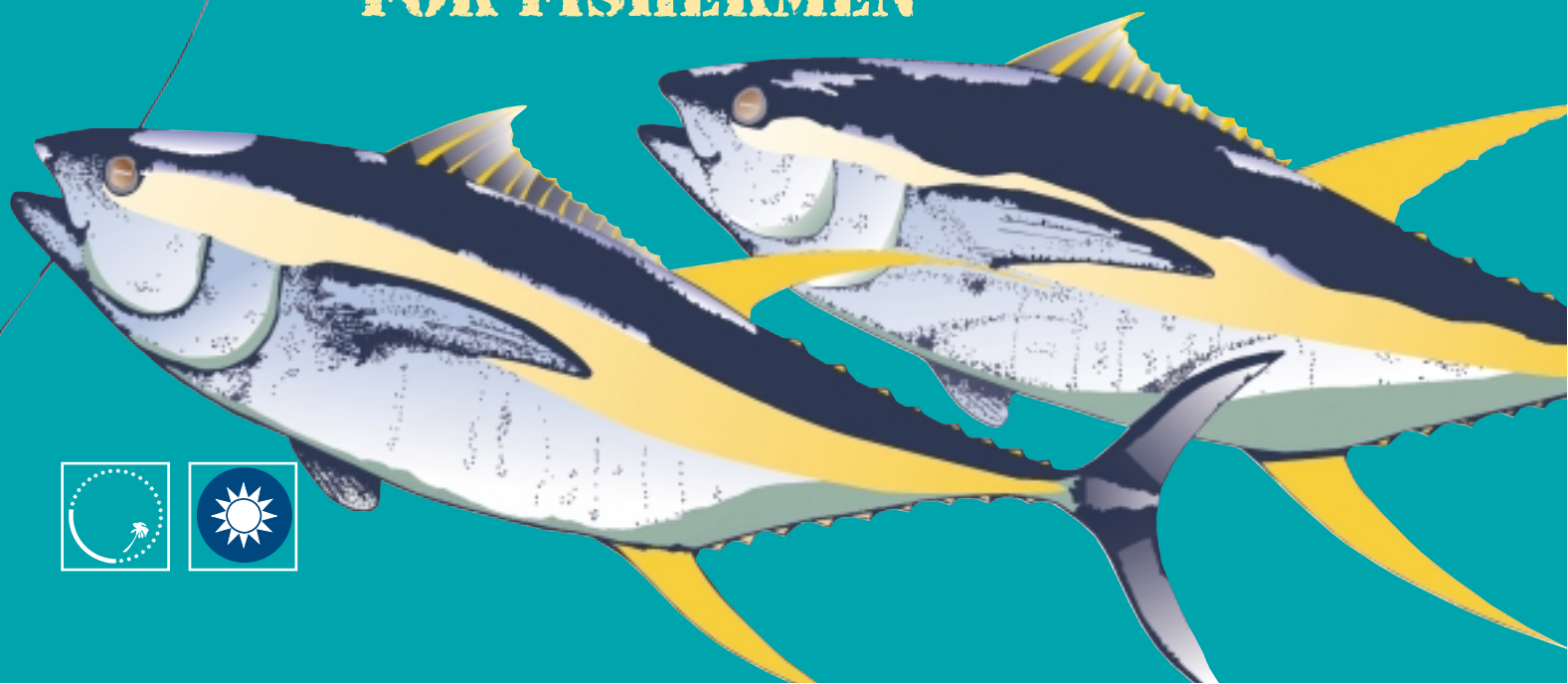

**A MANUAL
FOR FISHERMEN**



Secretariat of the Pacific Community

Vertical Longlining
and other
Methods of Fishing
around
Fish Aggregating Devices
(FADs)

A MANUAL FOR FISHERMEN

Garry L. Preston, Lindsay B. Chapman and Peter G. Watt



Government of Taiwan/ ROC



Coastal Fisheries Programme
Capture Section, SPC

© Secretariat of the Pacific Community, 1998

The Secretariat of the Pacific Community authorises the reproduction of this material, whole or in part, provided appropriate acknowledgment is given.

Original edition: English

‘Pacific Community’ is the new name of the South Pacific Commission (SPC). The new name became official on 6 February 1998, in commemoration of the 51st anniversary of the 1947 Canberra Agreement which originally established the SPC.

The change of name does not alter the established SPC acronyms, but their meanings are modified.

‘Pacific Community’ applies to the total organisation, i.e. the member governments, the Conference, the CRGA and the Secretariat. **‘Secretariat of the Pacific Community (SPC)’** refers to those who provide the service to members of the Community.

Secretariat of the Pacific Community cataloguing-in-publication data

Preston, Garry Leonard

Vertical Longlining and other Methods of Fishing around Fish Aggregating Devices (FADs):
A Manual for Fishermen / by Garry L. Preston ... [et al.]

1. Fishing methods and gear—Oceania 2. Fisheries—Equipment and supplies
3. Longlining (fisheries)—Oceania 4. Bait fishing—Oceania
I. Pacific Community, Coastal Fisheries Programme Capture Section

639.202

AACR2

ISBN 982-203-645-0

Authors

1. Garry L. Preston, Gillett, Preston and Associates Inc., BP 11041, 98802 Noumea Cedex, New Caledonia
2. Lindsay B. Chapman, Fisheries Development Adviser, Secretariat of the Pacific Community, BP D5, 98848 Noumea Cedex, New Caledonia
3. Peter G. Watt, Masterfisherman, Secretariat of the Pacific Community, BP D5, 98848 Noumea Cedex, New Caledonia

Prepared for publication at
SPC headquarters, Noumea, New Caledonia
and printed by
Stredder Print, New Zealand

ACKNOWLEDGMENTS

Preparation of this manual benefited from the inputs of several current and former SPC Fisheries Programme staff, including Paul Gates, Steve Beverly, Aymeric Desurmont, Peter Cusack, Paul Mead, Paxton Wellington, Michel Blanc, Marie-Ange Roberts, Satalaka Petaia and Julian Dashwood. The authors are grateful for their contributions.

A few of the drawings in this manual were prepared by the senior author but most are from a variety of other sources. Some were specially drawn by Yannick Le Bars, while others were 'borrowed' from other SPC manuals, reports or training course materials. A small number were drawn from the following excellent publications on fishing: *Fishing Hawaii Style*, Volumes 1 and 2, by Jim Rizzuto (Hawaii Fishing News, Honolulu, Hawaii) and *The Complete Book of Fishing Knots and Rigs (International Edition)* by Geoff Wilson (Australian Fishing Network, Croydon, Australia).

Preparation of this volume was kindly funded by a grant from the Government of Taiwan/ ROC.

UNITS, CONVERSIONS AND ABBREVIATIONS

Metric units are used throughout this document. Conversions between metric and imperial units are as follows:

1 millimetre (1 mm)	=	0.039 inch	1 inch	=	25.38 mm
1 centimetre (1 cm)	=	0.393 inch	1 inch	=	2.54 cm
1 metre (1 m)	=	3.281 feet	1 foot	=	0.305 m
1 metre (1 m)	=	0.546 fathoms	1 fathom	=	1.83 m

Some manufacturers use nominal equivalents in converting between metric and standard US measures. The nominal equivalents of the metric measures given in this document are as follows:

5 mm	=	3/16 inch	16 mm	=	5/8 inch
6 mm	=	1/4 inch	19 mm	=	3/4 inch
8 mm	=	5/16 inch	22 mm	=	7/8 inch
10 mm	=	3/8 inch	25 mm	=	1 inch
12 mm	=	1/2 inch	50 mm	=	2 inch
14 mm	=	9/16 inch	100 mm	=	4 inch

Apart from the units of measure noted above, other abbreviations used regularly in this document include the following:

dia.	Diameter
FAD	Fish Aggregating Device
SPC	Secretariat of the Pacific Community

DISCLAIMER

Reference to trade names of products or processes in this document does not constitute endorsement by any of the sponsoring agencies named above. Reference to persons in any particular gender is understood to include persons of the opposite gender unless otherwise stated, or made explicit by the context.

TABLE OF CONTENTS

INTRODUCTION	1
CHAPTER 1: BASIC INFORMATION AND TECHNIQUES	3
A. What are FADs?	4
B. FAD fishing methods.....	6
C. Safe navigation	8
D. Avoiding accidents and injuries.....	10
E. Handling and preparing ropes	12
F. Rope splicing.....	14
G. Joining lines using knots and crimps.....	16
H. Knots for attaching hooks and swivels.....	18
I. Bait	20
J. Using a sea anchor	22
CHAPTER 2: VERTICAL LONGLINING	25
A. Basic gear configuration	26
B. The mainline	28
C. Branchlines	30
D. Other gear and equipment.....	32
E. Setting the line from a basket	34
F. Setting the line from a Samoan handreel.....	36
G. Setting multiple lines	38
H. Hauling the line.....	40
I. Targeting fish concentrations	42
J. Fishing with a sea anchor	44
K. Gear care and maintenance.....	45
L. Scaling up the fishing operation.....	46
CHAPTER 3: OTHER FAD-FISHING METHODS	49
A. Mid-water tuna lines	50
B. The 'drop-stone' method.....	52
C. The 'palu-ahi' method	54
D. The 'ika-shibi' technique.....	56
E. Trolling around FADs	58
F. Catching bait around FADs	60
G. Other possible FAD bait-fishing methods.....	62
H. Non-FAD bait-fishing methods	63
CONCLUDING REMARKS	64

INTRODUCTION

Fish aggregating devices, or FADs, are floating rafts or buoys anchored in deep water which, for reasons not yet fully understood, cause tuna and other types of oceanic fish to gather around them. FADs were first introduced into Pacific Island countries and territories in the late 1970s, and are likely to be a continuing feature of fisheries development in the region.

The introduction and growing use of FADs have opened up new fishing opportunities for the region's fishermen, but in many cases these have not yet been taken full advantage of. Fishermen are often unaware of the potential yields that can be generated by fishing around FADs, and may not know of suitable fishing techniques or have access to the right gear and equipment.

SPC Masterfishermen working on fisheries development projects in the region were some of the first to begin adapting fishing gear and principles to the special conditions of FADs in order to help small-scale fishermen benefit from this new resource. Combining the principles of traditional mid-water tuna handlining and industrial tuna longlining, they began to experiment with multi-hook mainlines set around FADs. These 'vertical longlines' were fished directly from the boat, tied off to the FAD, or allowed to drift free suspended from floats or buoys. This gear arrangement simultaneously got numerous baits into the water, focussed the fishing effort close to the FAD, and allowed fishing over a range of depths.

Gear used in the early SPC trials was bulky, with mainlines usually being rigged from the 6 or 7 mm tarred Kuralon rope used by large-scale longliners. The lines were stored in boxes on the fishing vessel, with setting and hauling being done by hand. Later trials made use of braided nylon, and then monofilament nylon, for the mainlines. These smaller diameter lines were less bulky and could be stored, set and hauled using different types of fishing reels. This made fishing quicker and easier and kept the lines neatly stowed without tangling. These smaller lines were also less affected by currents and so required smaller sinkers to keep them hanging straight up-and-down in the water.

With the successful development of this lighter, more compact gear, SPC Masterfishermen began working on techniques to concentrate more hooks in the fishing area. At first they tried setting multiple free-drifting lines, but found that it was often hard to keep track of the gear because individual lines frequently drifted far apart. This led to the practice of attaching the individual mainlines together using sections of floating rope short enough to keep the lines within a fishing area, but long enough to prevent them from tangling with each other.

This fishing method, which had by now become known as vertical longlining is still evolving, with SPC continuing its work on streamlining the gear and increasing the number of hooks that can be concentrated within a particular area. In addition, fishermen who have adopted the technique have also incorporated their own innovations and ideas in response to the conditions in their own particular areas.

This manual provides the basic information that a fisherman will need in order to try vertical longlining. In providing this information, the authors recognise that the technique will need to be varied in response to the wide range of different fishing vessels and conditions in the Pacific Islands region. We have therefore tried to avoid being too prescriptive and giving specific recommendations. Instead, where there are a range of options we have tried to present all of these so that the fisherman can make up his own mind as to which suits him best.

Vertical longlining is not restricted to FADs, and should be productive anywhere where more traditional forms of tuna fishing, such as mid-water handlining or trolling, are successfully used to catch tunas and other oceanic fish types. These other fishing methods are also described briefly in this manual, in order to provide fishermen with a full set of background information on ways of catching tuna around FADs and elsewhere.

As well as the present document, SPC has produced a number of other manuals, handbooks and training materials on fishing and FADs. *Trolling Techniques for the Pacific Islands: A Manual for Fishermen* provides complete information on trolling methods and gear, while the three volumes of the *SPC FAD Handbook* are aimed at helping Fisheries Departments to establish FAD programmes which will provide maximum benefits for the local fishing industry. Various SPC training and public information materials (including lecture notes, videos, overheads and posters) on fishing, FADs and safety at sea are available, as also are construction diagrams and specifications for the fishing reels described in this manual. Further publications are planned dealing with other aspects of fishing not so far covered by the above materials. For more information write to SPC at the address on the last page of this document.

CHAPTER 1

BASIC INFORMATION AND TECHNIQUES

- A. WHAT ARE FADs?
- B. FAD FISHING METHODS
- C. SAFE NAVIGATION
- D. AVOIDING ACCIDENTS AND INJURIES
- E. HANDLING AND PREPARING ROPES
- F. ROPE SPLICING
- G. JOINING LINES USING KNOTS AND CRIMPS
- H. KNOTS FOR ATTACHING HOOKS AND SWIVELS
- I. BAIT
- J. USING A SEA ANCHOR

INTRODUCTION

This chapter provides background information on FADs, the fish they aggregate, and a summary of some of the fishing methods used around them. It also gives information on the main safety considerations that relate to FADs—reliable navigation to and from the FAD, and prevention of accidents and mishaps while fishing. In addition, the chapter describes basic techniques that apply to many FAD fishing methods, not just vertical longlining. Knots and splices suitable for making up fishing lines are shown, and information on bait types and the best ways to bait the hook is given. The correct use of a sea anchor, which is both a useful aid in drift fishing and a valuable piece of safety equipment, is also described.

SECTION 1A : WHAT ARE FADs?

Oceanic fishes such as tunas are often found gathered around floating logs and other drifting objects, sometimes in very large numbers. Having observed this behaviour, fishermen learned that finding and fishing near floating objects often produced higher catches than when fishing in the open ocean. Some industrial fishing techniques rely on this tendency for tuna to gather near natural floating objects to improve their catch. Many tonnes of tuna have sometimes been taken around even small bodies of floating debris.

TRADITIONAL FADs

In the early 1900's, fishermen in Indonesia and the Philippines began building floating rafts of bamboo and other materials to attract schools of fish. They moored these rafts to the sea floor with natural fibre ropes secured to baskets of stones that served as anchors. These man-made structures were the first fish aggregating devices, or FADs, to be used in the tropical Pacific Ocean.

The use of FADs by both small-scale fishermen and industrial fishing fleets is now very widespread. In the Philippines over 3,000 FADs are in use, and most yellowfin tuna production comes from them.

Much research and effort has been put into improving FAD technology over the last 15 years. Most of these efforts have concentrated on keeping FADs in place in the often harsh environment of the open ocean.

Simple bamboo-raft type FAD

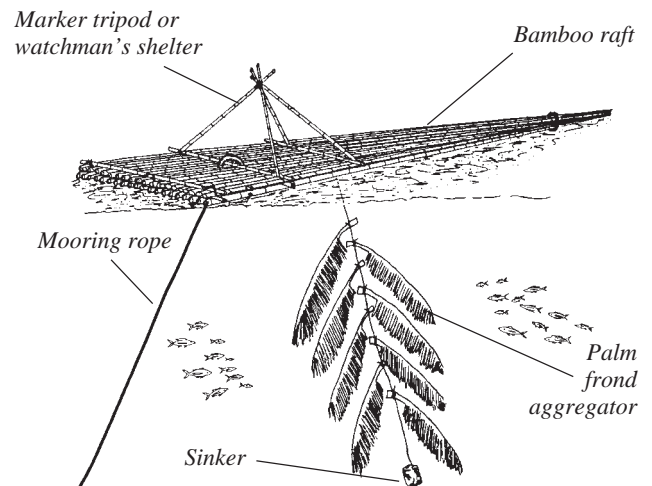

SPC 'Indian Ocean' type raft with catenary curve mooring

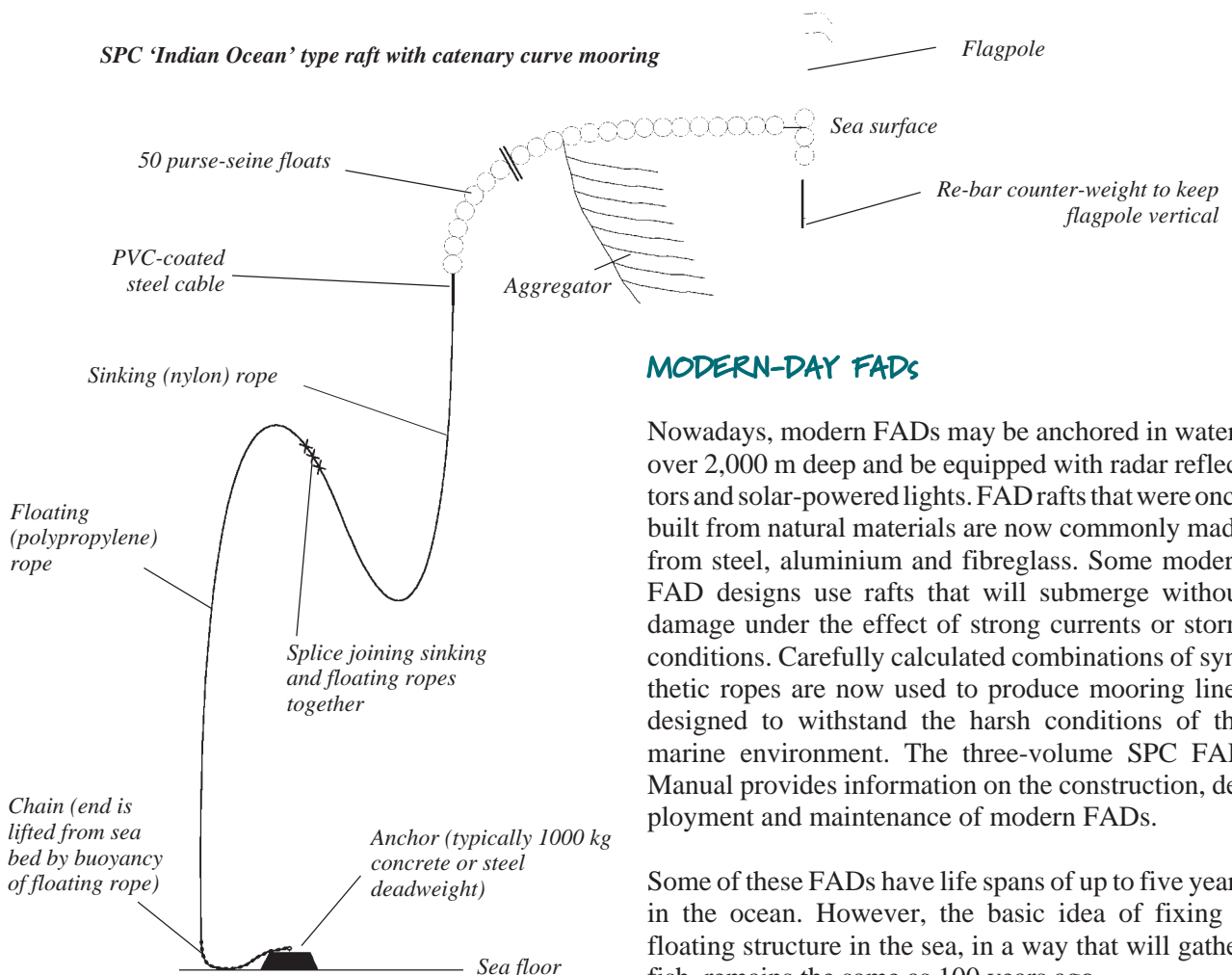

MODERN-DAY FADs

Nowadays, modern FADs may be anchored in waters over 2,000 m deep and be equipped with radar reflectors and solar-powered lights. FAD rafts that were once built from natural materials are now commonly made from steel, aluminium and fibreglass. Some modern FAD designs use rafts that will submerge without damage under the effect of strong currents or storm conditions. Carefully calculated combinations of synthetic ropes are now used to produce mooring lines designed to withstand the harsh conditions of the marine environment. The three-volume SPC FAD Manual provides information on the construction, deployment and maintenance of modern FADs.

Some of these FADs have life spans of up to five years in the ocean. However, the basic idea of fixing a floating structure in the sea, in a way that will gather fish, remains the same as 100 years ago.

WHY FADs ATTRACT FISH

Although fishermen have been using FADs for nearly a century and much is now known about the behaviour and biology of tunas and other pelagic fishes, the reasons why FADs attract fish still remain largely unexplained. Research into this question, mostly through observing fish behaviour in association with FADs, has suggested several possibilities, of which the most important are the 'shelter and protection' and the 'orientation' theories. The first theory suggests that both the FAD raft and the mooring line offer protection from predators to fish which remain close to or 'hide' behind them. The second argues that fish use the FAD as a physical reference point in an ocean generally devoid of such signals. In either case it is apparent that the fish are able to find their way to and from the FAD when they wish. Although fish may spend days or weeks associated with a FAD in this way, other urges eventually cause them to move on and subsequently be replaced by new arrivals.

SPECIES ATTRACTED

FADs aggregate different fish at various depths depending on the time of year. Small tunas are usually found schooling near the surface. Larger yellowfin, bigeye and albacore tunas generally gather near FADs at depths between 50 m and 300 m, although they can also be found closer to the surface at times, especially at night. Other fish species, including rainbow runner, mahimahi, sharks and billfish are also commonly attracted to FADs.

There is no evidence to suggest that FADs increase the overall number of tuna in a given area of ocean. Rather, they gather fish from a large area to a smaller one and so make them easier to find and catch. FADs allow fishermen to concentrate their fishing effort in an area where the fish are themselves concentrated. As a result, overall catches and catch rates around FADs tend to be higher than in open water fishing.

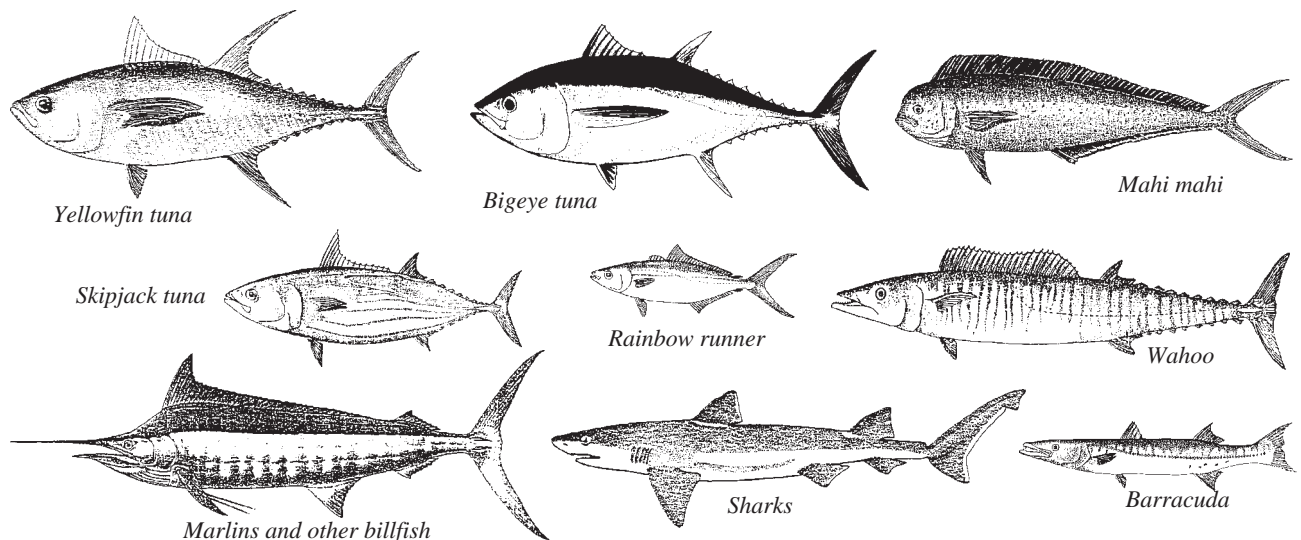
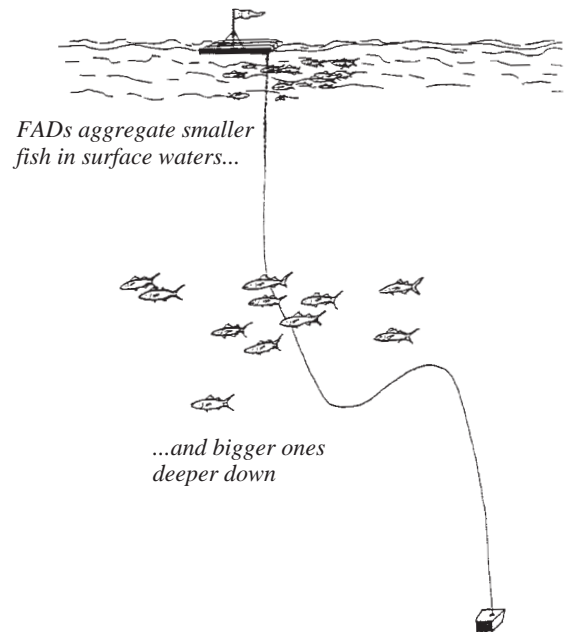

Some of the large oceanic fish species that FADs aggregate

BENEFITS OF FADs

FADs are not always 100 per cent effective, and may be lost if the raft or mooring rope is damaged by bad weather, vandalism, or fish-bite. Those which do work, however, provide many advantages to the small-scale fisherman. He spends less time and fuel in searching for fish, and he can be more easily located, in the event of a breakdown. There may also be disadvantages to FADs, the most common one being that a lot of fishermen may go out to fish the FAD at the same time, causing competition and gear conflict.

SECTION 1B: FAD FISHING METHODS

There are numerous fishing methods that are particularly suited to use around FADs. Most of these can also be carried out in the open sea, but in most cases will be more productive around FADs.

FISHING METHODS COVERED IN THIS MANUAL

Mid-water hand-lining

Hand-lining for large, deep-swimming tunas and other mid-water fish is practised throughout the Pacific Islands in many forms, both traditional and modern. At its most simple, this type of fishing uses a weighted line with a baited hook which is fished at depths of 50–300 m in areas where tunas occur. A variation on the technique is to buoy the lines off and allow them to drift so that several can be set at once. A traditional form of mid-water handlining is ‘drop-stone’ fishing in which the hook is carried down to the desired depth by a stone which is then released, leaving the bait to drift naturally in the water. A more specialised variation is the Hawaiian ‘ika shibi’ night-fishing technique in which an underwater light is used to attract bait around the boat, which in turn attracts tuna. All these methods are suitable for use around FADs, and are described in detail in chapter 3.

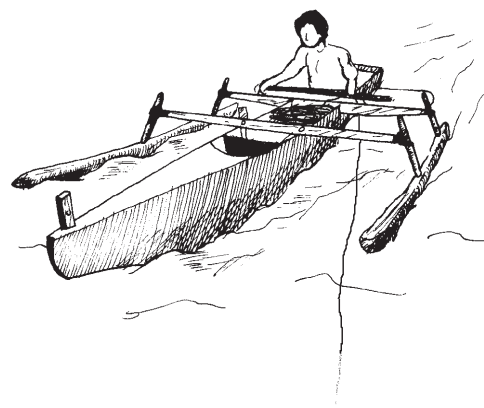

Vertical longlining



Vertical longlines can be fished from the boat, tied to a FAD...

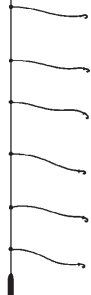

Vertical longlining is based on the same principles as mid-water handlining but uses a weighted mainline rigged with a number of branch lines carrying baited hooks. This technique enables a small-boat fisherman to simultaneously fish a range of depths while also concentrating many hooks close to a FAD. The line can be fished from a boat, tied to a FAD, or set to drift, supported by surface floats, thus allowing several lines to be fished at once. Vertical longlining has been developed and improved by SPC over the past ten years, and is the main subject of the present manual. It is described in detail in chapter 2.

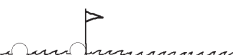

...or buoyed off and allowed to drift

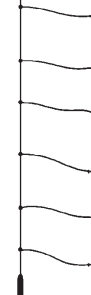

Trolling

Surface trolling with feathers, plastic lures or natural bait is a common and simple method for FAD fishing. The gear is inexpensive and can be fished from a small boat. Larger craft can also carry out sub-surface and deep-trolling around FADs, using diving boards, downriggers or cannonballs in order to target the larger fish normally found at greater depths. Trolling under a variety of different conditions is described in detail in SPC Handbook No. 28, ‘Trolling Techniques for the Pacific Islands: A Manual for Fishermen’. Section 3E of the present manual summarises those elements that relate specifically to trolling around FADs.

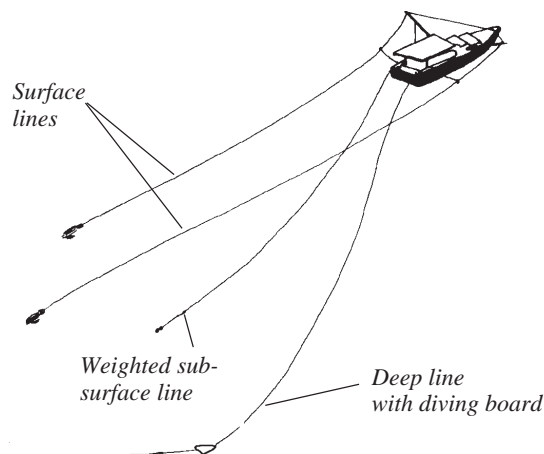

Bait fishing

As well as aggregating tunas and other large pelagic fish, FADs also attract schools of smaller types, including bait fish. These can be caught using traps, jigs, nets or other fishing methods, and then used as bait for vertical longlining or mid-water handlining. Bait catching around FADs is described in section 3F.

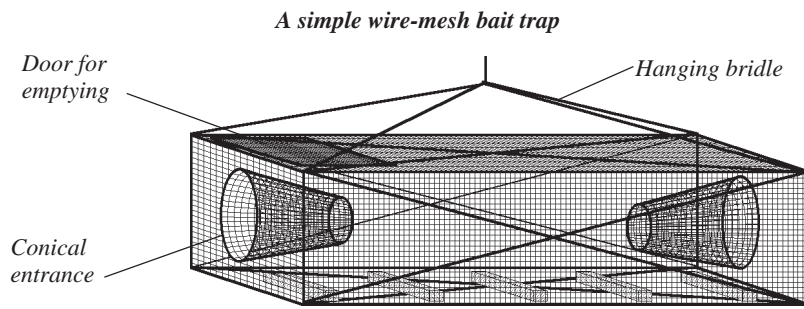

TUNA FISHING METHODS NOT COVERED IN THIS MANUAL

Pole-and-line fishing

Pole-and-line fishing is a surface fishing method used by both artisanal and industrial fishing vessels. Unbaited, barbless hooks tied on a fixed length of line attached to a fishing pole are jigged in an actively feeding surface school of yellowfin or skipjack tuna. In the industrial version of this method, as well as in certain small-scale pole-and-line fisheries, the fish are encouraged to bite by bringing them into a feeding frenzy using live bait cast into the water from the fishing boat. On industrial vessels, water sprays around the boat are used to imitate the movement of baitfish and to hide the fishermen from the tuna.

Traditional and industrial pole-and-line fishing

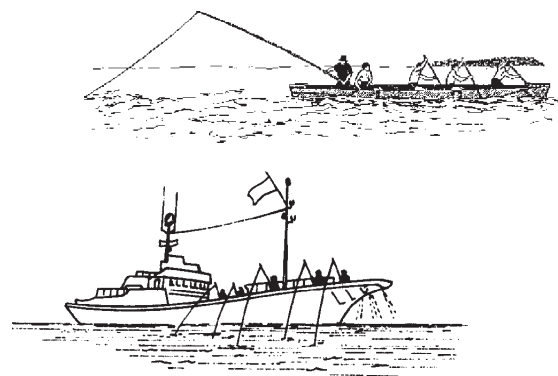

Ring-netting and purse-seining

Ring-netting is a FAD fishing method commonly used in the Philippines. Schools of bait-fish or smaller pelagic species aggregated around a FAD are drawn to the fishing-boat by the use of lights. A ring-net is set around the school and is closed in around the fish. A lampara net uses the same principle, but is hung specially to form a floor which will stop the fish escaping downwards when the net is hauled. The same technique is carried out on a larger scale by purse-seiners, whose nets are fitted with a purse-line to close the net under the fish, and which may take many tons of tuna in a single set.

Purse-seining

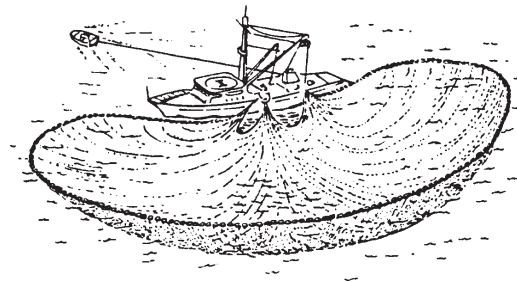

Horizontal longlining

Horizontal longlining has been practised in the Pacific by Asian fishing fleets for over 100 years, and more recently has been adopted by the region's local fishing vessels, which have been able to take advantage of gear improvements and better technology to carry out longlining with smaller boats and fewer crew. The principles of small- to medium-scale horizontal longlining will be covered in detail in a forthcoming SPC manual.

Horizontal longlining

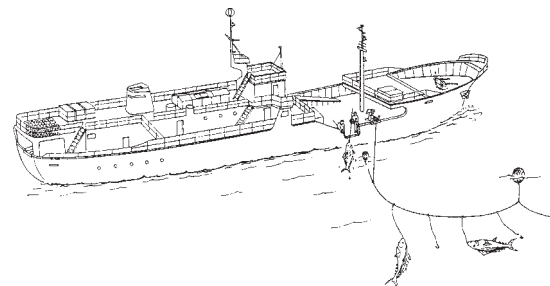

Others

Many other commercial and sport-fishing methods can also be productively used around FADs, including jigging, spin-casting and even spear-fishing.

SECTION 1C: SAFE NAVIGATION

FADs are normally thought of as improving the safety of fishing operations. If for some reason a fishing boat operating around a FAD suffers a breakdown, it is more likely to be found because the searchers will know where to start looking for it. On the other hand, fishing around FADs may present fishermen with challenges and dangers that they are not familiar with, especially if they are used to operating only in areas close to shore or to other boats. FADs are usually several miles off the coast, so fishermen working around FADs in small boats must make sure they are properly prepared and equipped for offshore operation.

Compass

The most essential piece of equipment for FAD-fishing is a compass. Normally a hand-bearing compass, designed to allow bearings to be taken from prominent objects, is the most useful for a small vessel. The fisherman must know how to use the compass properly—that is, he must be able to take a bearing, follow a course, and work out the reciprocal (opposite direction) of a heading. Ideally he should also be able to plot bearings on a chart and perform elementary coastal navigation. Correct use of a compass will help the fisherman to find his way to the FAD and, more importantly, to find his way home again afterwards. **No fisherman should ever go FAD-fishing unless he has a compass on board and knows how to use it.**

Using bearings

Normally the organisation which set the FAD—usually the local Fisheries Department or a fishing company—will publicise the FAD's position, either so that fishermen can find it, or so that local shipping can avoid running into it. If the position is known, then a fisherman equipped with a compass and marine chart can calculate the bearing and distance of the FAD from his fishing base, and use this information to navigate to and from it. Alternatively the agency responsible for setting the FAD may also publicise compass bearings and distances relative to prominent local features such as reef passages, marker buoys, or objects on the shore. Again, the fisherman can use his compass to follow the bearings and locate the FAD.

Three different types of hand-bearing compass

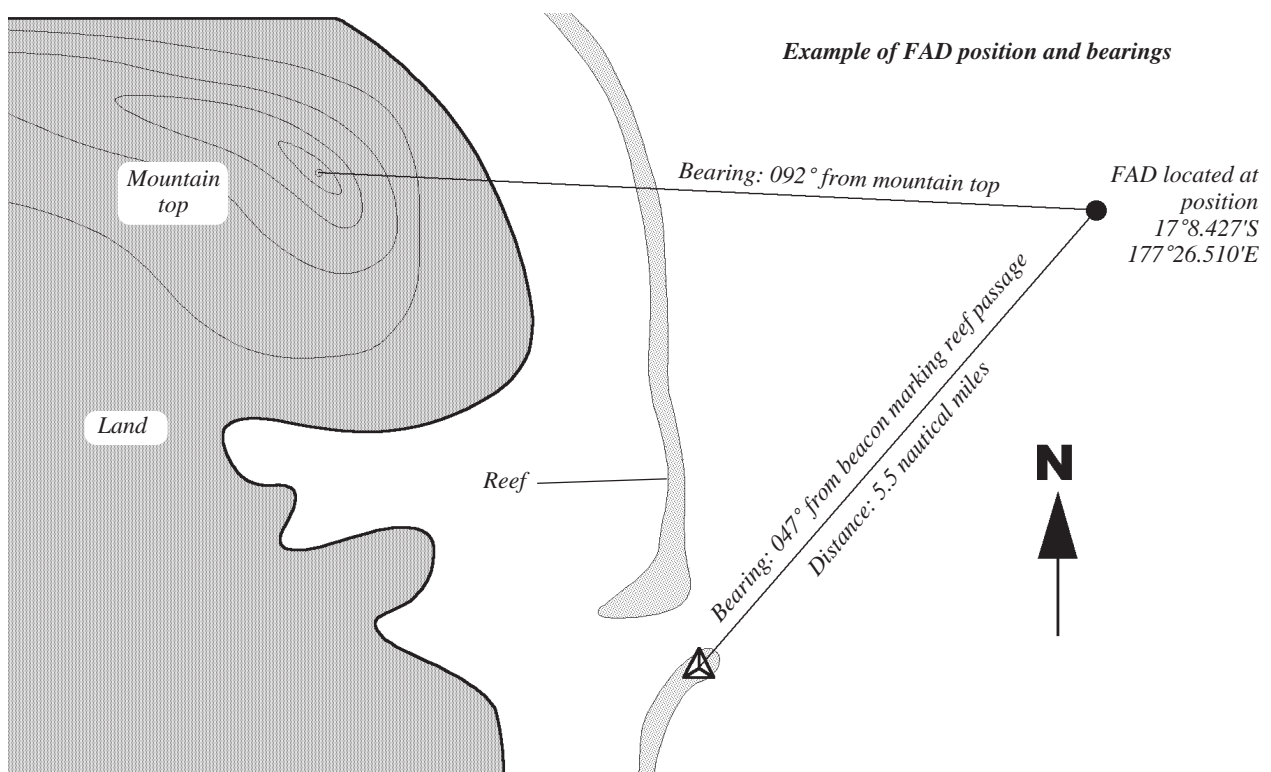

Using transit bearings

A transit bearing is an imaginary line created when two prominent landmarks or other features are in alignment. Examples might include lining up two mountain peaks, one in front of the other, or a navigation beacon on the reef with a church steeple on the shore. The best transit bearings are taken on objects which are clearly visible and far apart; objects that are close together will not give an accurate transit bearing.

It may not be possible to use transit bearings when far offshore from low islands or atolls, because the land is not high enough to allow landmarks to be seen. In this case the fisherman will be much more reliant on the use of his compass. However, when FADs are deployed around high islands it is usually possible to find a couple of transit bearings which intersect at the location of the FAD. These can be identified during the first fishing trip and, once noted, make it a lot easier to find the FAD or to come back to it after moving away (for instance when chasing tuna schools).

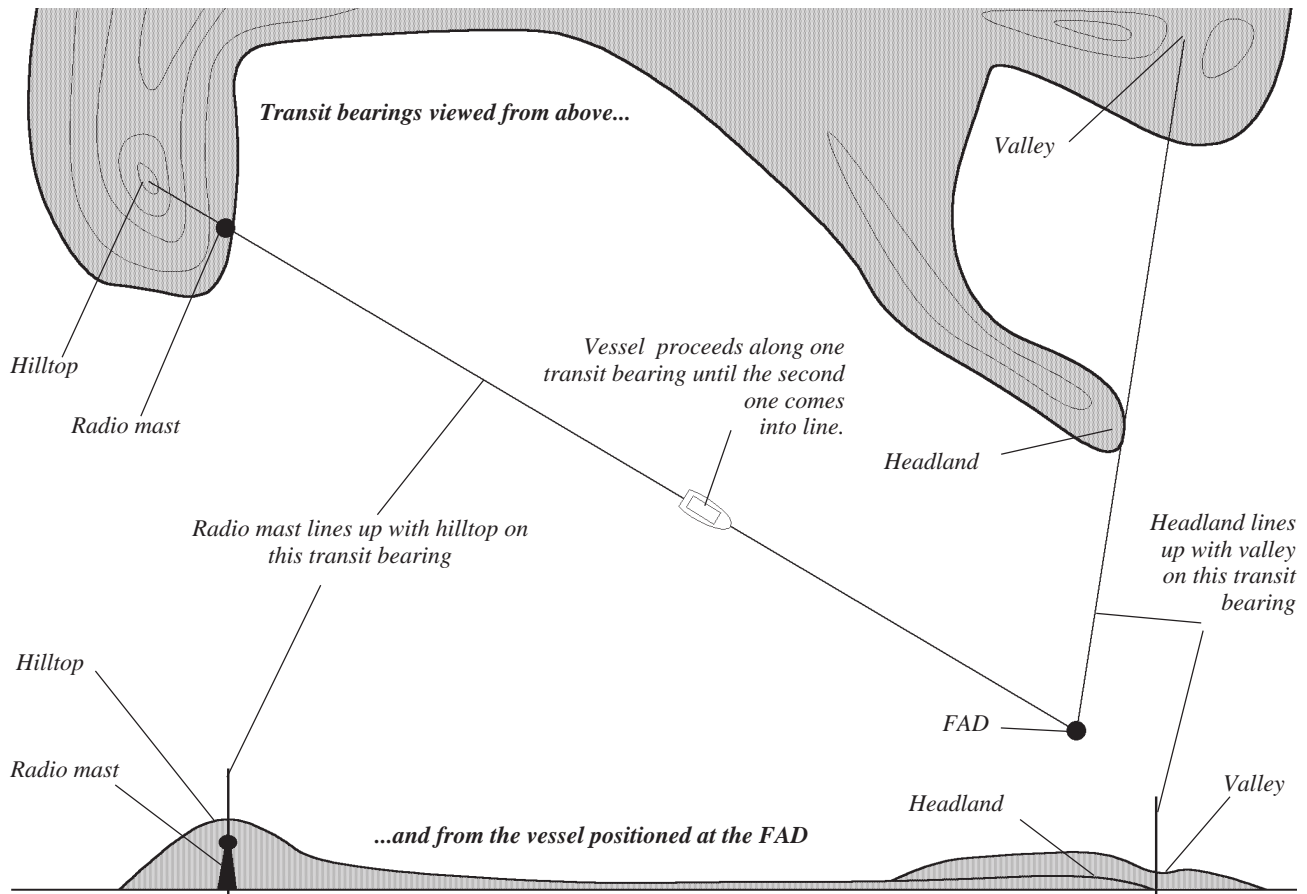

The fisherman should always be able to approach the FAD by first lining up one of the transits, and then following the transit line until the landmarks of the second transit are also in alignment.

Global positioning system (GPS) receivers

GPS receivers are electronic positioning devices which assist navigation by reference to satellites, and which allow FADs (or any other marine feature) to be located quickly and easily. The position of the FAD is entered into the unit which then guides the fisherman to the correct spot by providing information on course to be followed and distance to be covered. In the past GPS units have been expensive and limited in their availability in the Pacific Islands, but have been gradually getting cheaper and more widespread. In recent times the first hand-held GPS units costing less than US\$ 100—cheaper than the cost of a good hand-bearing compass—became available. As GPS units continue to fall in price and become more widely available they will be increasingly used by FAD fishermen.

Despite its usefulness, a GPS unit is a supplement for a compass, not a substitute. All electronic devices can develop flat batteries, break down or malfunction, especially if dropped in sea water. **A compass should always be carried even if a GPS is used.**



A low-cost hand-held GPS unit

SECTION 1D: AVOIDING ACCIDENTS AND INJURIES

PLANNING

Many accidents at sea are caused by carelessness or lack of preparation. Vessels go adrift for simple and easily avoidable reasons, such as running out of fuel, or minor engine breakdowns. In many cases these incidents could easily have been avoided, but instead they cause great suffering, enormous search and rescue costs, and even loss of life. All boat owners have a responsibility to themselves and their crew to ensure that they have done their best to avoid accidents, and are in a position to cope with them if they do happen. Because they are usually far offshore, FADs can be traps for careless or ill-prepared fishermen.

Before heading to the FAD...



Pre-departure check-list

Before setting off to sea, every fisherman should do the following:

- check the weather forecast. If in doubt be prepared to cancel the trip or cut it short;
- tell someone who cares (family or friends) where he is going and when he plans to return, so that the alarm can quickly be given if he does not come back on time;
- check that the engine is in good condition and running well;
- check that all safety equipment and supplies are on board.

Safety equipment

The type of safety equipment and supplies carried will depend on the type of vessel, the duration and distance of the fishing trip, and local regulations. Even small boats should have a minimum of equipment and supplies, including:

- a compass;
- tools and spare parts for engine repair;
- an anchor and anchor rope;
- a bailer which will float if dropped over the side;
- food, and plenty of drinking water or coconuts;
- spare fuel;
- knives.

Other equipment should include some or all of the following:

- alternative means of propulsion: oars, emergency sail rig, or spare outboard motor;
- a sea anchor (parachute);
- flotation devices: life-jackets, life-raft, longline floats, plastic containers
- signalling devices: a heliograph (signalling mirror), waterproof torch, flares, air horn, VHF radio, EPIRB (emergency position-indicating radio beacon).

For a fisherman whose boat sinks, clinging to a fishing float or a 20-litre plastic container may mean the difference between life and death.

Safety and life-saving equipment



INJURIES

Fishing boats are places where sharp hooks, gaffs and knives are being used to catch and subdue lively and often powerful fish. This is particularly true when fishing around FADs, where the fish caught are likely to be large and energetic. Minor injuries such as cuts and bruises are almost a certainty, and there is great potential for more serious accidents. The sensible fisherman will take all reasonable precautions to reduce the chances of accidents to a minimum and be ready to cope with them if they do occur.

Avoid accidents

The boat's skipper should ensure that all his crew adopt safe working practices and avoid injury to themselves and other crewmen. In particular, **gloves should always be worn** to protect the hands from lines, hooks, fish spines and teeth, and knives. When not in use, fishing gear and knives should be stowed safely where they will not slide around or be stepped on.

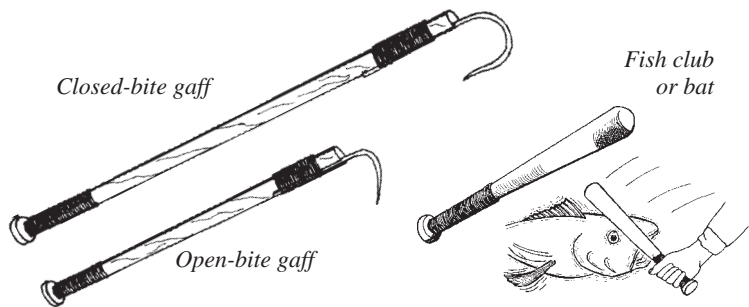
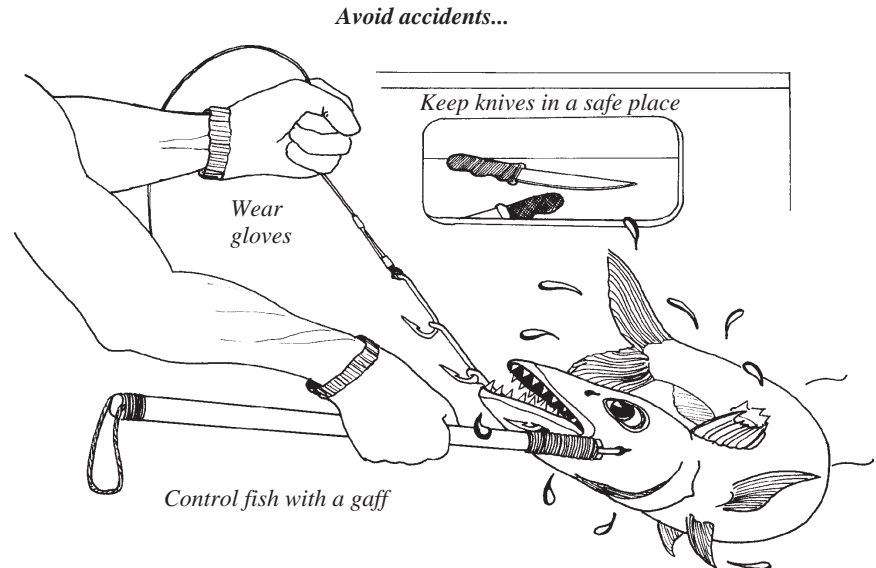

A couple of gaffs and a fish club or bat are essential equipment when fishing around a FAD. A large fish should be gaffed through the head and then stunned with a fish club as soon as it has been brought on board. This not only stops the fish from causing injuries, but also prevents damage to the fish flesh which could reduce its value.

When trolling or vertical longlining using a wooden handreel (see section 2F), a common cause of injury is from the reel's spinning handle. The reel should be fitted with a simple braking system, such as a loop of inner-tube rubber to prevent it from spinning free, as described in section 2F. Always keep well out of the way of the reel handle when a large fish is making its initial run.

First-aid kit

In many countries, the law requires boat owners to carry a basic first-aid kit. Even where this is not mandatory, fishing boats should have some first-aid supplies on board. These should include aspirin or panadol (for pain), sticking plasters, a couple of small bandages and some antiseptic liquid and ointment.

Every boat should have a first-aid kit with...

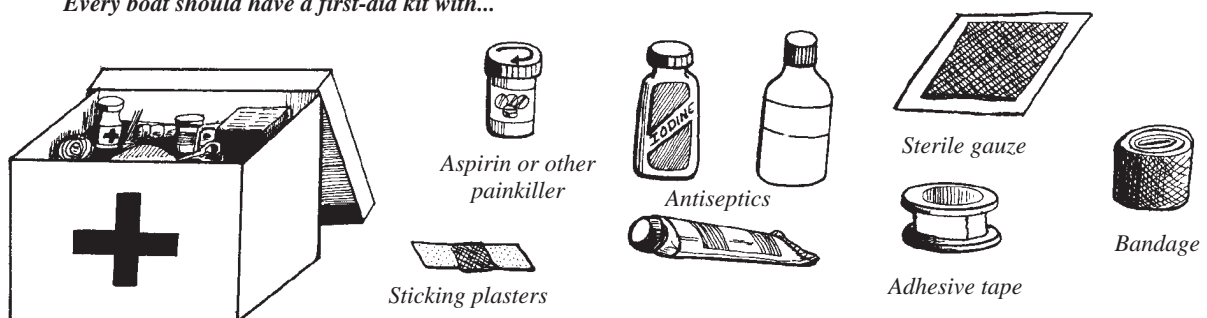

SECTION 1E: HANDLING AND PREPARING ROPES

MEASURING OUT

Many of the fishing techniques described in this manual require ropes and lines to be measured out so that, when finished, the gear will be fishing at a known or pre-determined depth. The easiest way to measure out the length of a piece of rope or line is for the person doing the job to first measure his arm-span, then count out the correct number of spans that will give the required length of rope. A typical adult male arm-span is 1.5–1.8 m.

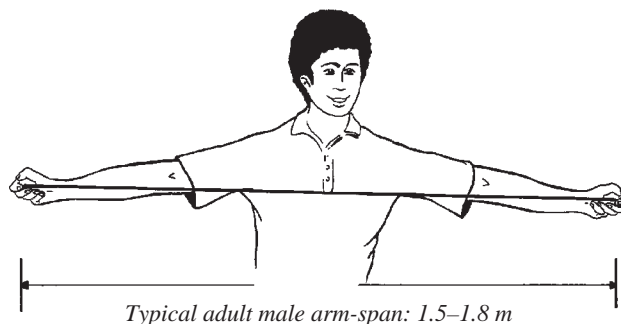

Sealing a synthetic rope end by melting

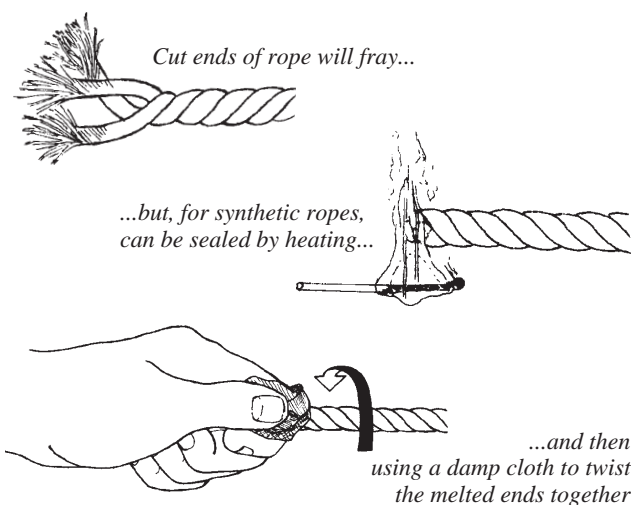

SEALING ROPE ENDS

The ends of most types of rope will quickly begin to fray or unravel once they are cut, making handling difficult, so it is necessary to seal them. There are various ways of doing this, depending on the material from which the rope is made.

Melting

The ends of many synthetic ropes can be quickly melted into a solid plug by using a match or cigarette lighter to heat them for a few moments. Some ropes will begin to burn during the process, and give off noxious fumes, so this job should be done outside, or in a well-ventilated place. Once the rope is hot and visibly melting, a damp cloth is used to twist the rope ends together and extinguish any burning parts. The result is a fused rope-end which will not fray.

Whipping

Another method, suitable for natural fibre ropes which do not melt, is to whip the rope ends. This is done using light twine or dental floss as shown in the diagram below.

To whip a rope-end, a loop of twine is laid along the rope...

...and tightly wrapped. The end of the twine is passed back through the loop...

...and the other end is pulled tight, drawing the connection inside the wraps. The twine ends are then cut off.

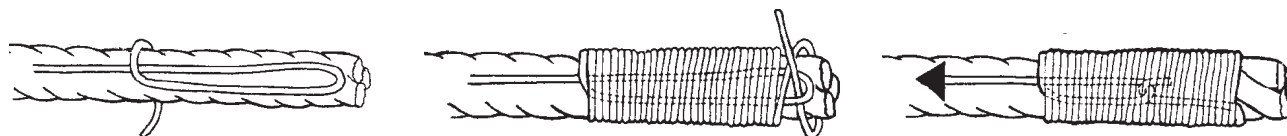

END SPLICING

Another way to seal rope ends is to make an end splice. There are several types of end splice, a couple of which are shown on the next page.

To make a splice, the strands at the end of a piece of rope are unlaidd and then passed back between the strands in the body, or standing part, of the rope. With soft ropes the strands of the standing part can be separated by hand, but for a hard or stiff rope a tool may be needed to do this. A fid is a tool specially made for separating rope strands while splicing, but a screw-driver can also be used.

Fids are used to spread rope strands during splicing

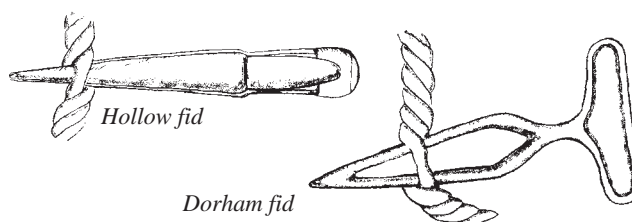

Before starting a splice it is usually necessary to seal the ends of the individual rope strands so that they do not fray during the splicing process. This can be done using tape or rubber bands, which will normally stay in place long enough to allow completion of the splice, or by melting or whipping as already shown.

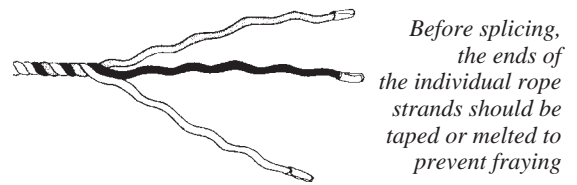

Crown knot

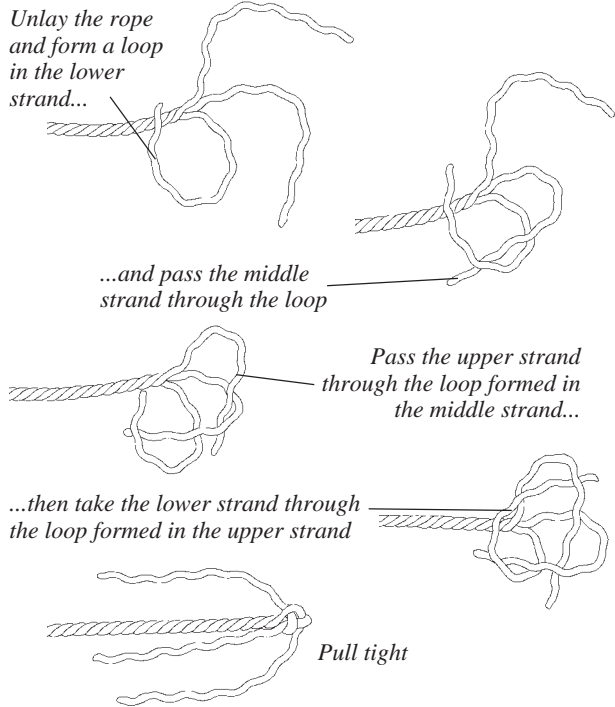

Crown knot

The method for making a crown knot is as follows:

- unlay the end of the rope for 15–20 centimetres;
- form a loop in the lower strand;
- pass the middle strand over the lower strand and down through the loop;
- repeat the procedure, passing the upper strand over the middle strand and down through its loop;
- pass the lower strand over the upper strand and down through its loop;
- pull tight.

In practice a crown knot is rarely used on its own except as a temporary means of preventing a rope from fraying while tying other knots and splices. The most common use of a crown knot is in preparation for a back splice, as shown below.

Back splice

Commence with a crown knot, then;

- using a spike, loosen the first strand below the crown knot;
- taking the adjacent left-hand strand, pass it under the loosened strand against the lay;
- turn the rope to the right and repeat the process with each of the other strands. Pull each strand end tight until they fit snugly into the laid strands of the standing part of the rope;
- continue the splice, passing each strand end over and under a strand in the laid part of the rope. Pull each strand end tight as the work progresses;
- when sufficient splicing has been done, taper the splice by taking more tucks with only two of the strand ends, and then only one;
- trim off the strand ends and roll the splice between your hands to smooth it into shape.

Back splice

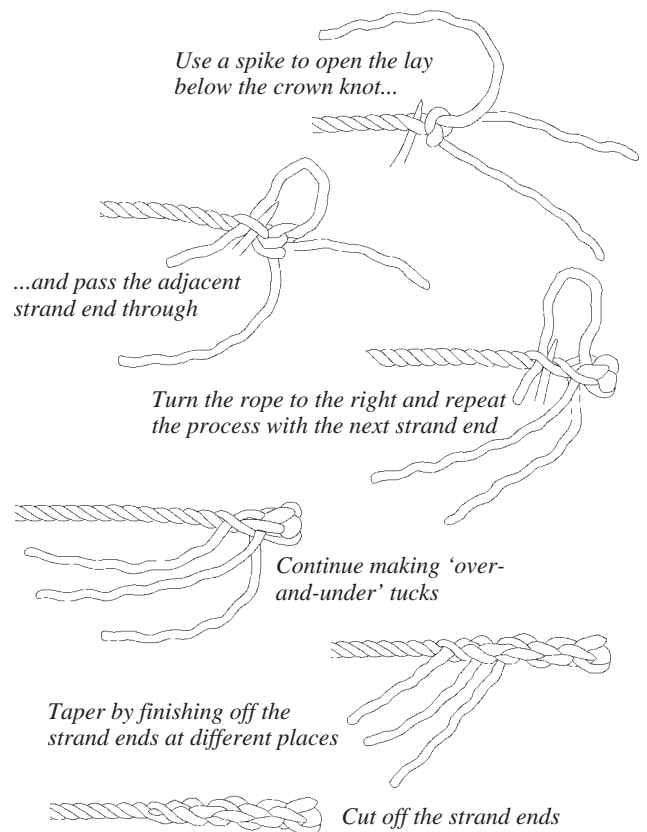

SECTION 1F: ROPE SPLICING

SPLICE TYPES

When three-strand ropes are to be joined permanently, this should be done using splices rather than knots. Although splices take more time and skill to make, they are stronger than knots and will reduce the chance of the line snagging or causing tangles.

The main types of splice used in making up FAD fishing gear are:

- the **eye splice**, used to make a loop which can serve as an attachment point for another piece of line;
- the **fisherman's** or **double splice**, which is used to quickly join two ropes, leaving a loop between them;
- the **short splice**, which is used to join two lengths of rope end-to-end.

Eye splice

Eye splices are a good way to end a rope as they provide an attachment point which is useful in vertical longlining and in many other fishing methods.

To make an eye splice, if necessary first tape or seal the end of each strand of the rope. (This is not needed when using tarred kuralon, the type of rope most commonly used in vertical longlining). It may be helpful to number the ends, or to mark them with different colours. Unlay the ends until you have enough length to work with—about 20–25 cm is enough for 10–12 mm diameter rope. With some ropes, it may be necessary to tie or tape the strands together to prevent them unlaying too far.

Double the rope back so that the finished eye will be the size that you want. Form the eye and spread the strands fanwise, placing them against the rope where it is to be entered. Untwist the body of the rope a little and pass the centre end under the centre strand. Then, pass the left end under the next rope strand to the left and the right end under the next strand to the right. If the rope is hard-laid, you may need a spike or fid to separate the strands widely enough.

If this has been done correctly all three ends should be sticking out at the same level, evenly spaced around the main body of the rope. If they are not like this, pull them out and start again.

Continuing the splice is easier than starting it. Pull the first tucks tight, then take any end and pass it over the next strand and under the one after. Repeat for the other two ends, so that each shows two tucks in the main body of the rope. The ends should still be even and regular.

Repeat this procedure until each strand has 3 or 4 tucks, then cut off the ends close to the body of the rope. To make a tapered splice, make additional tucks with two of the ends so that all three finish at different places, then cut off. With slippery ropes, or those which fray badly, it is worth whipping the splice to ensure that the ends never slip back through the strands.

Eye splice

Unlay the rope strands and, if necessary, tape or seal the ends

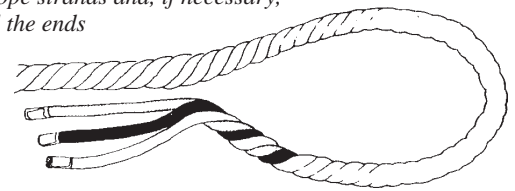

Pass the ends through the standing part of the rope so they are at the same level

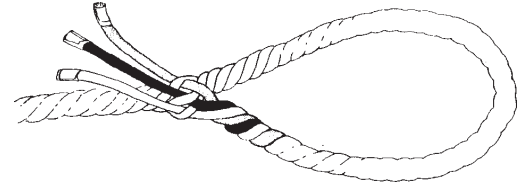

Make sure they are not at different levels, like this

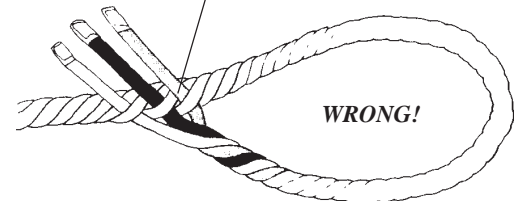

Pass each end over one strand and under the next. Repeat the process 3 or 4 times

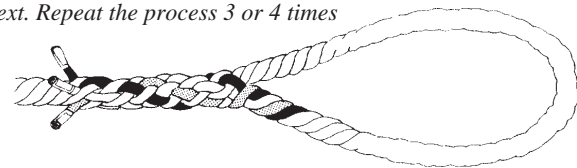

Taper the splice by finishing off the rope ends at different levels

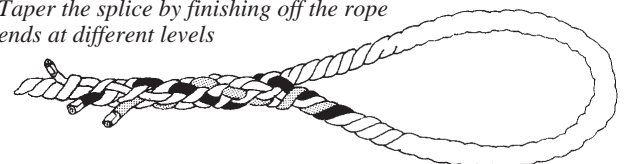

To make a neat finish, whip the end of the splice

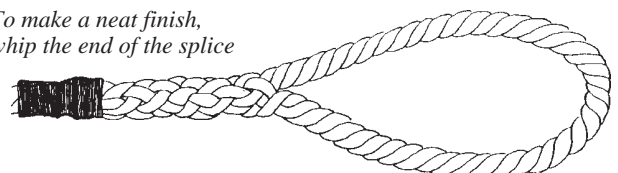

Fisherman's or double splice

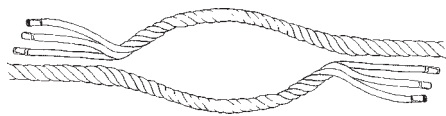

Unlay the two rope ends and position them as shown

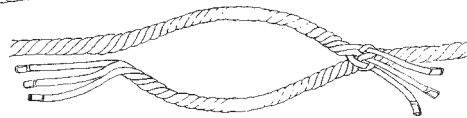

Pass the strand ends from one rope through the body of the other, exactly as for an eye splice



Complete the tucks and taper as for the eye splice

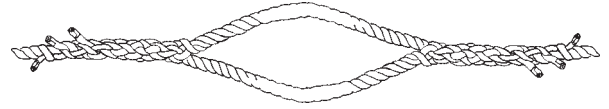

Repeat with the other set of rope strands

Fisherman's splice

The procedure for making this splice is similar to making two eye splices. However instead of splicing the end of a rope back into itself, two ropes are used, with the end of each one being spliced into the standing part of the other.

Short splice

Unlay the rope ends...

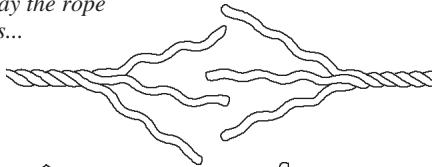

...and 'marry' them together

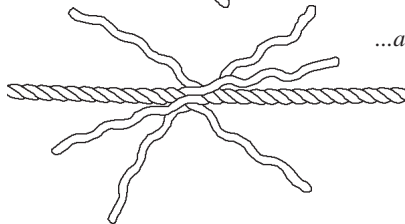

Whip or tape one set of strands, then start splicing the other set

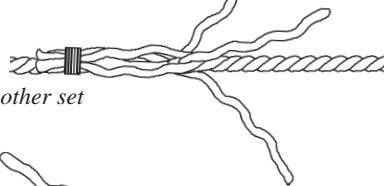

Pass the first free strand through the lay of the rope...

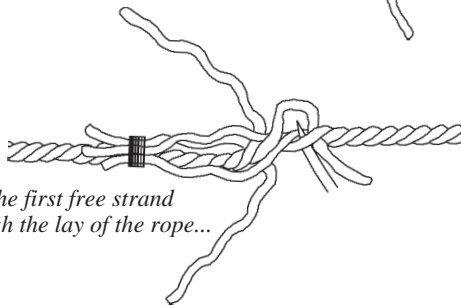

...then repeat with the next free strand, and so on.

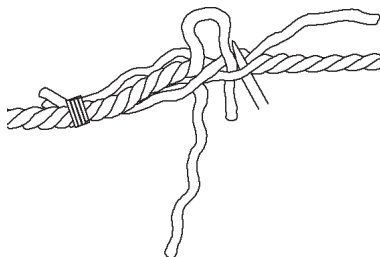

Continue passing the free strands under and over the lay of the rope

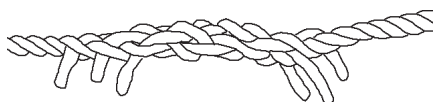

Once enough tucks have been made, undo the whipping and repeat the process with the other set of strands

When finished, cut off the tag ends and roll the splice in your hands to smooth it out

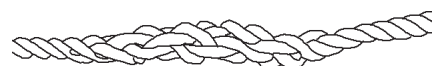

Short splice

To make a short splice:

- unlay the ends of the two ropes to be spliced, and if necessary tape or seal them;
- 'marry' the two ends so that the strands are interleaved with each other;
- tightly whip or otherwise secure one set of ends around the standing part of the other rope;
- take any one of the unsecured strands and, using a spike, tuck it under a strand of the other rope, against the lay;
- repeat the procedure with all three unsecured strands;
- continue the splice with over and under tucks, then taper it as described for the eye splice;
- remove the whipping and repeat the procedure with the other set of strands;
- when finished, cut off the loose ends of the strands and roll the splice between your hands to finish it.

SECTION 1G: JOINING LINES USING KNOTS AND CRIMPS

The following diagrams illustrate some of the knots that will be useful to a fisherman carrying out vertical longlining and other FAD fishing methods.

JOINING ROPES

Bowline knot

The bowline is good for making a temporary attachment loop in ropes. It is strong, will not slip, and is fairly easy to undo. However it is not good for slippery lines and will not hold in nylon monofilament.

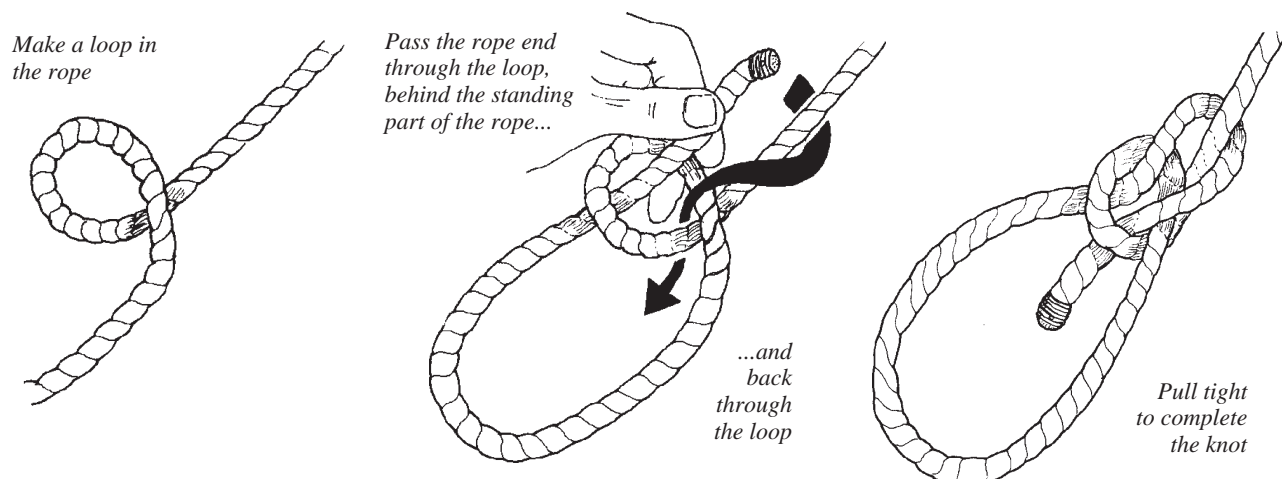

Sheet bend

This is a quick and simple knot, easy to undo, for attaching one rope to a loop (an eye splice or bowline) in another.

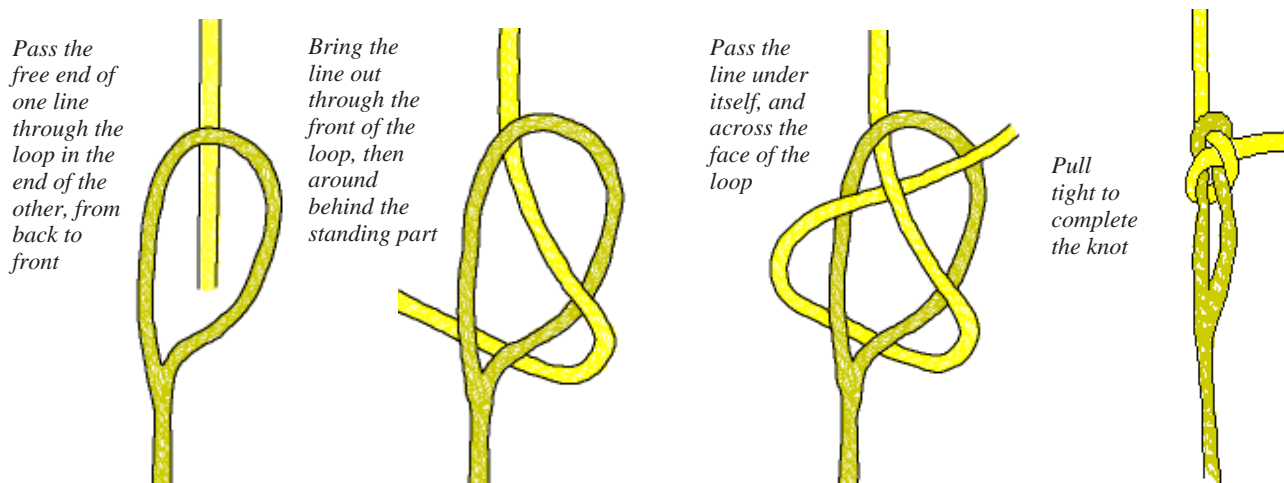

JOINING LINES

Crimps

If they are available, crimps (also called sleeves or swages) can be a good way to join monofilament lines together, or to attach hooks and swivels to monofilament and other fishing lines. Crimps are tubular lengths of brass, aluminium, or other suitable metal which are slid over the line and then pressed onto it using a special crimping tool. The crimp may be circular, oval or figure-8 shaped in cross-section, and when squeezed shut, grips hard on the line to prevent it from slipping.



Using crimps can be a lot faster than tying knots, but there are some disadvantages. Apart from the fact that they add extra cost to the gear, crimps may lead to extra wear and tear on the line. High-quality crimps are bevelled on the inner edge, but cheaper ones have a sharp corner which can bite into the line and weaken it through gradual cutting. Aluminium crimps will oxidise, and the rough oxidised edges can again cause wear close to the crimp. The best crimps, which are made of brass and have bevelled inner edges, are also the most expensive.

Both the crimping tool and the crimps can be costly or hard to obtain in many Pacific Island countries. Some fishermen have been tempted to cut costs by using pliers or a vice instead of buying the proper tool, but this is a false economy. The crimping tool is shaped to fit the crimps and will make a proper joint. Other tools will squash it out of shape and crush the line inside the crimp, weakening it and making it more likely to break under stress. Crimps should never be used unless the proper crimping tool is available.

Knots

Fishing is often carried out using monofilament or other light lines which cannot be spliced and which may slip unless special knots are used. All knots will weaken a line, sometimes reducing its breaking strain by more than half. The two knots shown below are recommended as being the strongest methods for joining monofilament and other fishing lines, and least likely to slip.

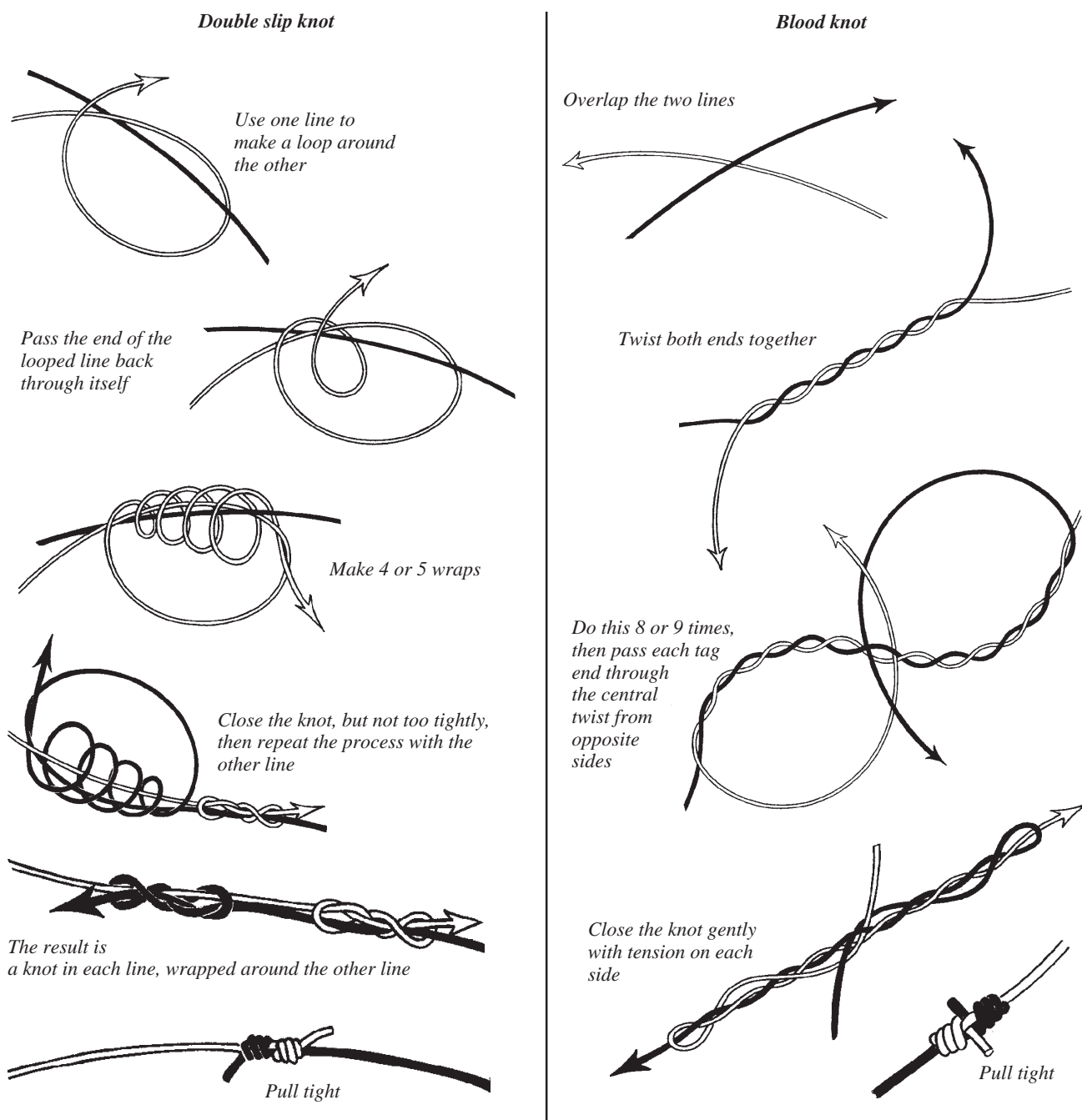

SECTION 1H: KNOTS FOR ATTACHING HOOKS AND SWIVELS

All forms of fishing around FADs require that hooks, swivels and other items of fishing tackle be attached at various places on the fishing line. In many cases the line is made of nylon monofilament which is slippery and does not grip well when tied. Many knots will come undone under tension, even if they appear secure when tied. Some knots which will hold, and which can be used for attaching tackle to monofilament lines, are shown below.

Palomar knot

The palomar knot is popular among Hawaiian fishermen, who claim it is easier to tie and less likely to slip than other knots. To tie the palomar knot, double the end of the line over in a loop. Pass the loop through the eye of the hook or swivel and tie it loosely in an ordinary overhand knot. Pass the eye of the loop over the body of the hook or swivel. Pull gently on the standing part of the line and the tag end together to close the knot. Tighten it up by pulling hard on the mainline, then cut off the tag end close to the knot.

Make a loop at the end of the line and pass it through the eye of the hook

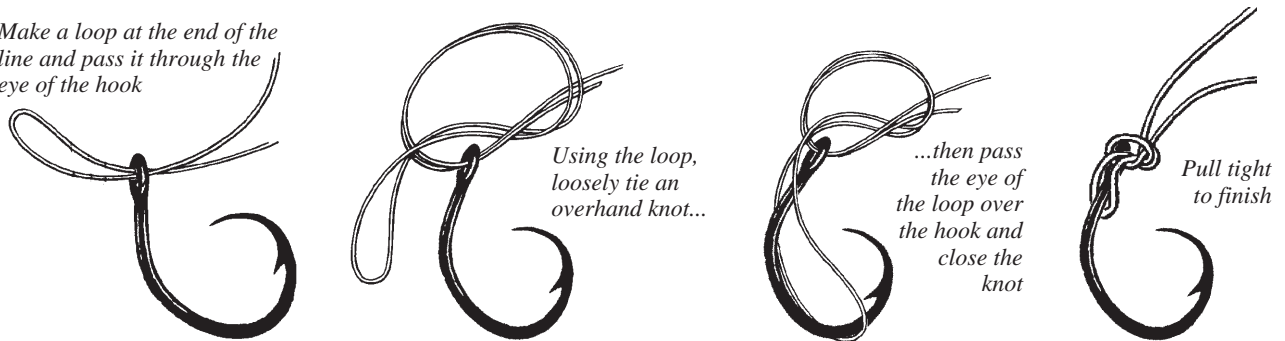

Although a very good knot, the palomar knot is more useful for hooks than for swivels. Once the first palomar knot is tied into a swivel, making the second one can be awkward because it becomes necessary to pass the whole line assembly through the loop in order to complete the knot.

Clinch knot

This is a good knot for light monofilament. To make it, pass the end of the line through the eye of the hook or swivel and double it back. Rotate the hook or swivel four or five times, twisting the tag end around the standing part. Lubricate the lines with saliva to make it slip more easily. Pass the tag end back through the loop at the end of the twist and pull gently so that the knot starts to close up. Pass the tag end back under itself. Hold the hook or swivel with pliers and pull hard on the mainline so that the knot pulls tight. Pull the tag end tight and cut off close to the knot, then flatten it with pliers or your teeth so that it cannot slip or be pushed back through.

Clinch knot

Thread the end of the line through the swivel or hook eye

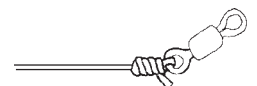

Pull tight

**Trilene knot**

The trilene knot is recommended by a manufacturer of nylon monofilament. It resembles the clinch knot in some ways, but to start it the line is passed through the eye of the hook twice instead of just once. The hook is then twisted around 4 or 5 times as with the clinch knot, and the tag end passed through the double loop of line where the hook is attached prior to pulling tight.

Trilene knot

Start with a double pass through the eye of the hook or swivel...

...then take 4 or 5 turns around the standing part

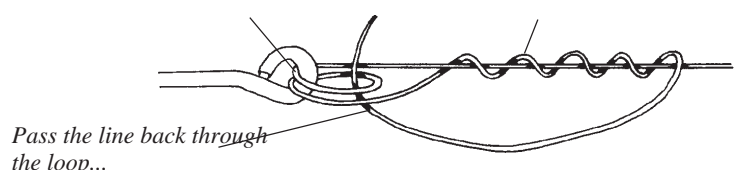

...and pull tight



Slip knot

As well as being good for heavy monofilament, this knot can also be used for braided lines like super-toto, dacron, etc., whose rough surface prevents slipping and makes the clinch knot (above) hard to pull tight.

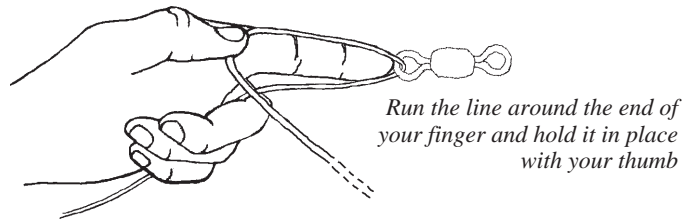
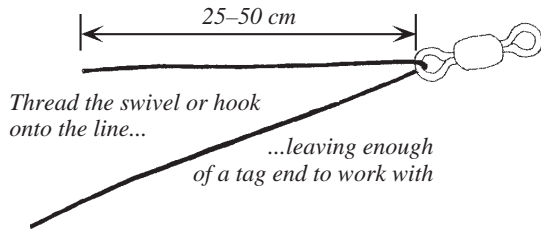

To make the slip knot:

- thread the line through the eye of the hook or swivel, leaving about 30 cm of line to work with;
- run the line down the inside of your forefinger, around your fingertip, and up the back of the finger, leaving the hook eye pulled against the fingertip;
- take four or five loose turns with the tag end around the finger, working back towards the fingertip;
- pass the tag end back along the finger inside the loose turns;
- remove the finger, holding the turns in place with the other hand, and pull gently on the tag end.

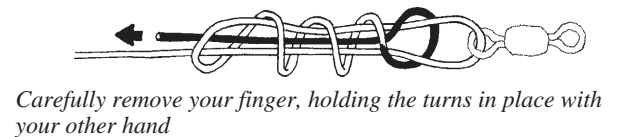
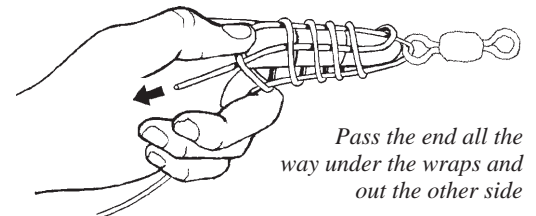
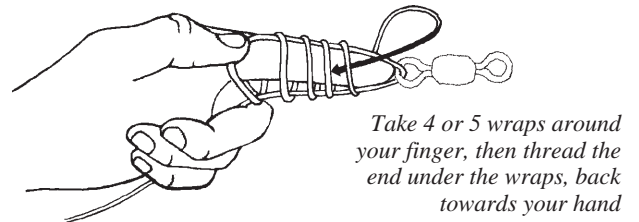

This will tighten the knot around the main line, leaving a long loop which can be pulled tight by holding the hook with pliers and pulling hard on the mainline.

Types of line protector

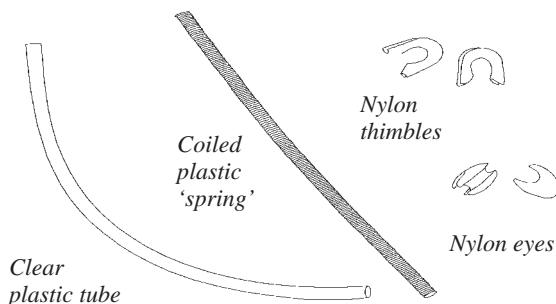

LINE PROTECTORS

When a hook or swivel is attached to the line using a crimp (see section 1G), the result is that the hook or swivel is free to swing on the loop that has been created, and this can cause wear on the line. To prevent excessive chafing, there are various types of line protector which can be slipped over the line before the hook or swivels is fitted. These include plastic tubes, coils of plastic or metal wound into tiny 'springs', and miniature thimbles. Some fishermen believe these items prevent gear loss, while others think they are a waste of money and a nuisance to use.

An alternative system, which provides line protection at no extra cost, is to make a Flemish eye in the line when fitting the hook or swivel. This is simply a double overhand knot which is tied loosely in the line through the hook or swivel eye. Making a Flemish eye will prevent the hook or swivel chafing through the line over time.

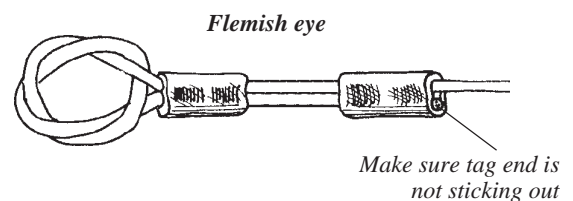

SECTION 1I: BAIT

One of the most important factors in vertical longlining, and in most other mid-water fishing techniques, is good bait. The type and quality of the bait affects not only the amount of fish caught, but also the economics of the fishing operation. Vertical longlining uses a lot of bait—10 to 20 pieces for every set, depending on the number of hooks—so it is important to use the most effective and affordable bait if the fishing operation is to make a profit.

TYPES OF BAIT

Some of the more common bait types used for vertical longlining and other types of mid-water line fishing are as follows:

- **mackerel scad**, an oceanic fish which is seasonally abundant in many Pacific Island countries. Large schools may form around FADs or in other areas outside the reef, and can often be caught by jigging with small feathered hooks, netting, or trapping (see section 3F for more information about catching bait). Catching the fish around the FAD immediately before fishing may allow them to be used as live bait;
- **big-eye scad**, a semi-coastal species found in many reef and lagoon areas. Again it can be captured by jigging or netting. Where there are industrial pole-and-line fisheries this species often figures in the catch from night-time bait-fishing using dip-nets. Since it is generally too big for tuna pole-and-line bait, it may be available to FAD fishermen;
- other locally-available **small pelagic species** including flying fish, Indian mackerel, garfish, hardyheads, sardines and pilchards, which can often be caught, or purchased on the local market. In some countries juvenile milkfish are available from fish farms. These have been tested as bait by industrial longliners with generally good results, especially when used live.
- **small tunas** such as skipjack, mackerel and frigate tunas. These are often captured during trolling operations around FADs. Although small individuals can be used whole, they are mostly too large for this purpose and have to be used as cut bait;
- **squid**. Various types are available, usually frozen and imported, although at least one species (the big-fin reef squid) occurs in Pacific Island lagoons and can be caught using special multi-hook squid jigs (see section 3G);
- commercial **longline bait**, which may be available in countries where there are industrial longline fisheries. Bait is generally sold frozen in large (10 or 25 kg) boxes and may include saury, pilchards, sardines, mackerels and squid.

Types of bait

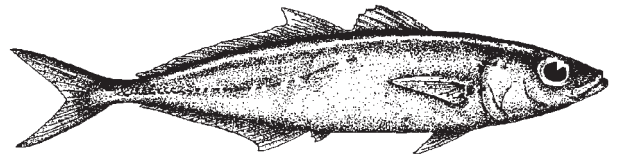

Mackerel scad (Decapterus spp.)

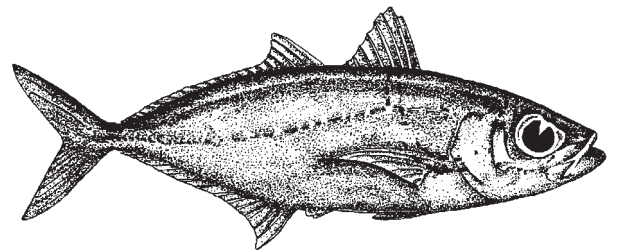

Big-eye scad (Selar spp.)

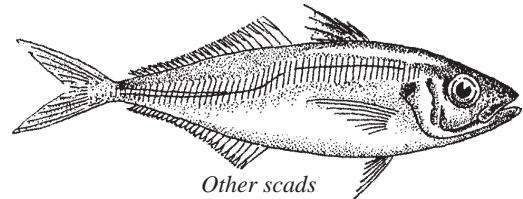

Other scads

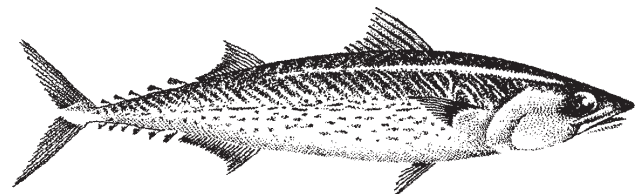

Mackerels

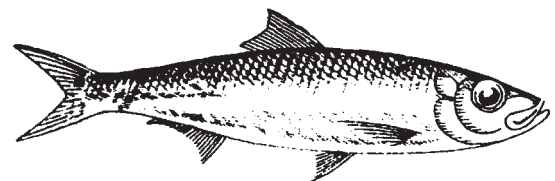

Sardines and pilchards



Squid



Japanese saury

There does not seem to have been much use of prawns, worms or other invertebrate baits for longlining, even though these are favoured for other types of fishing.

BAIT QUALITY

Depending on its size and condition, bait may be used whole or cut into pieces. In most cases whole baits are better than cut baits, and live bait generally results in the best catches, although catching bait and keeping it alive may be difficult. Some fishing tackle stores sell small battery-operated air pumps which are specifically made for keeping bait alive in a bucket or ice chest filled with sea water. By aerating the water and changing it regularly, it may be possible to keep the bait alive for several hours or a day.

Live or freshly-caught mackerel scad and bigeye scad are among the best baits. Whole fresh or frozen small pelagic fish such as pilchards, saury or sardines, or whole squid, are the next preference, followed by cut baits from squid or from oily fish such as tuna and mackerel. White-fleshed fish are generally not favoured for bait.

Frozen bait is often the most convenient, but is usually less effective than fresh bait of the same type. The primary advantage of freezing, apart from convenience, is that it can extend the availability of good bait species which may occur only seasonally in local waters. Freezing changes the consistency of the bait, making it softer, particularly if it is thawed and refrozen several times. Soft baits tear off hooks easier than fresh ones and often lead to missed strikes. It is possible to toughen up or harden previously frozen baits by salting and/ or sun drying them for short periods.

The number of pieces of bait per kg is an important cost consideration when the bait is being purchased. Mackerel scad and bigeye scad typically number 7–12 pieces/ kg while many imported frozen baits are available in a range of sizes, from 5–25 pieces/kg, with different grades often selling at different prices. In general baits at more than 25 pieces/kg will be too small, while those at less than 5 pieces/ kg are getting too large and may have to be cut, either for economic reasons, or just to get them on the hook.

BAIT RIGGING

The best method to rig fresh mackerel scad or bigeye scad is shown in the diagram opposite. To rig a bait in this manner hold the body of the bait in one hand, and take the hook in the other. Run the hook vertically downwards into the back of the bait just behind the first rays of the front dorsal fin. Then rotate the hook until the point exits the bait's body just behind the head. A similar method is used to rig live baits, but with the hook being placed a little further back along the body to avoid killing the bait.

Small baits or those which have been frozen may not hold on the hook when rigged in this way. In this case they can be rigged by hooking through the eyes or head. Whole squid should be rigged by passing the hook through the mantle, not through the head.

There are various ways of cutting and rigging cut baits. A good method is to take a 2 cm thick fillet of the bait fish with the skin still on, and cut this into triangular or rectangular pieces 8–10 cm long and 2–3 cm wide. One piece is enough for each hook, and is rigged by rotating the hook through the skin side first and then back out again. Care should be taken to ensure the bait is not too thick or rigged in such a way that it 'chokes' the hook, i.e. hides the point and reduces the chances of a hook-up.

Keeping bait alive

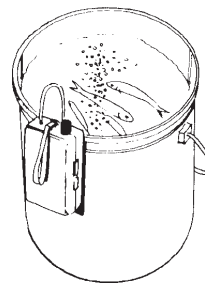

Bait can be kept alive in a bucket fitted with a battery-powered bait aerator...

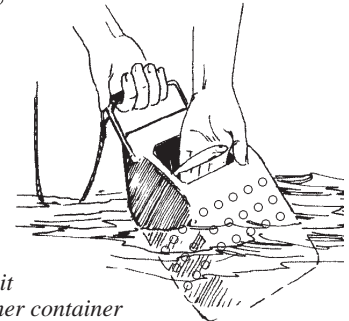

...or in a floating bait cage or other container

Bait rigging

Mackerel scad and bigeye scad should be hooked through the back, just behind the head

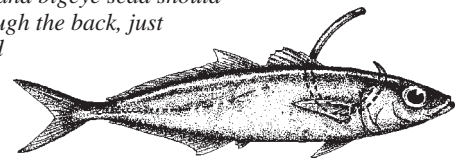

Squid are hooked through the mantle, or 'tail'



Cut baits are double-hooked so that the skin side faces outwards

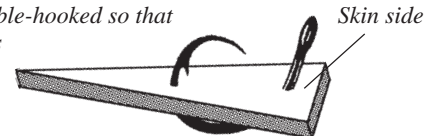

SECTION 1J: USING A SEA ANCHOR

A sea anchor, or parachute anchor, is a useful aid to vertical longlining and other FAD-fishing methods. The sea anchor will prevent the fishing boat drifting as a result of wind and instead cause the boat to move in the same direction as the current. This is extremely useful when vertical longlines are being allowed to drift (see section 2I), since the sea anchor will cause the vessel to stay relatively close to the gear. This results in less time and fuel wasted in following the gear using the motor, and less chance of losing the lines when they drift out of sight.

Sea anchors also provide a valuable safety function. If the engine breaks down, the sea anchor will prevent the boat from drifting too far away from its original position, which is a major aid in search and rescue operations. If the boat is caught in a storm, deploying the sea anchor causes the boat to ride with its bow facing the wind, reducing the likelihood of waves broaching the vessel and swamping it, possibly causing it to sink.

TYPES OF SEA ANCHOR

Sea anchors can be of various kinds. Purpose-built models are available commercially, and these consist of a cone made from strong synthetic cloth, and fitted with shrouds made from webbing similar to that used in car seat belts. In locations where there are military surplus stores, second-hand cargo parachutes can be purchased. Alternatively, an enterprising fisherman can improvise a sea anchor from a sheet of heavy canvas or tarpaulin and some rope.

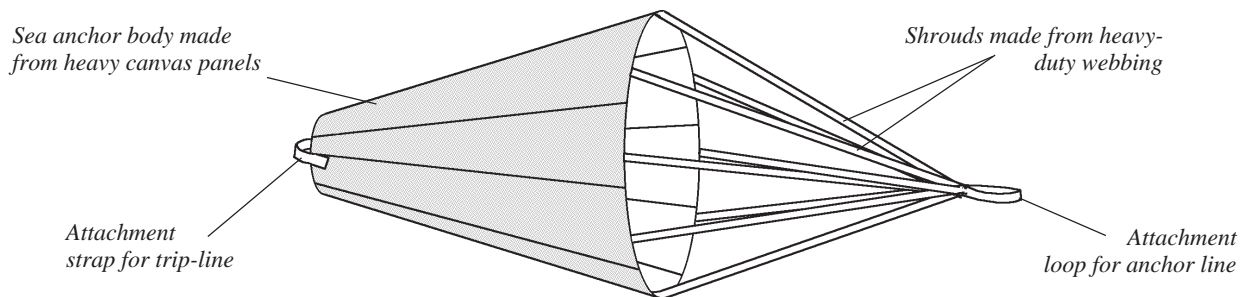

An important feature of a sea anchor is a vent at the top of the parachute which allows water to flow through. This is an essential feature which allows the sea anchor to fill properly when deployed and to empty when retrieved. It also helps prevent the anchor from tearing when the pull is very strong. On commercial sea anchors, a webbing strap is stitched across the vent and this serves as the attachment point for the trip line (see below).

RIGGING THE SEA ANCHOR

The sea anchor is rigged with several lines, as shown below: the **anchor line**, which takes the weight of the boat once the sea anchor is deployed; the **trip-line**, which is used to haul the sea anchor back on board the vessel; and the **haul-in line** which is used to recover the trip-line. Without a trip-line it is practically impossible to haul the anchor in due to the enormous water resistance the open parachute creates.

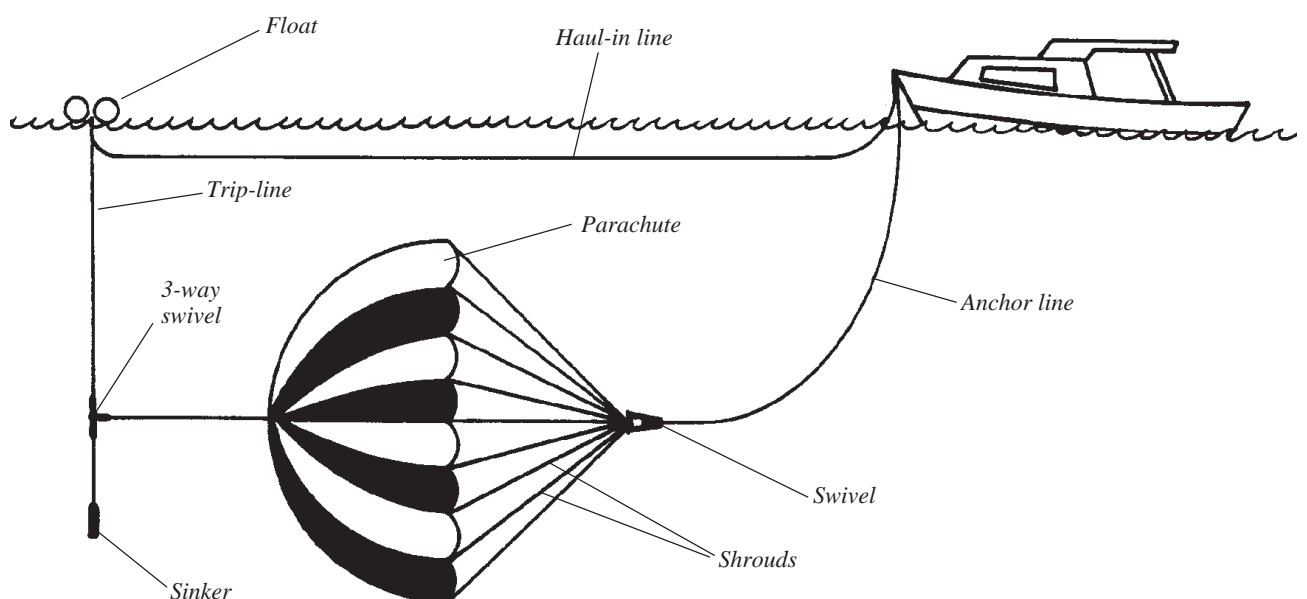

The anchor line is a length of strong rope, 20–30 m long, of the same diameter that would be used by the vessel if it were using a normal ground anchor. One end is connected to the shrouds of the sea anchor, the other to the boat.

If possible, a large swivel should be used between the anchor line and the shrouds. The best type to use is a dome swivel, which is specially made for this purpose. The swivel does two jobs: it stops the sea anchor from becoming twisted during use, and it provides a weight to prevent the parachute from being pulled to the surface and collapsing.

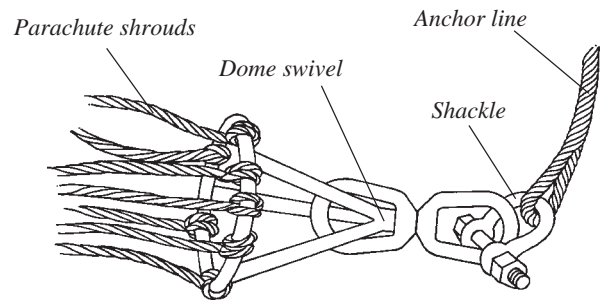

Dome swivel arrangement

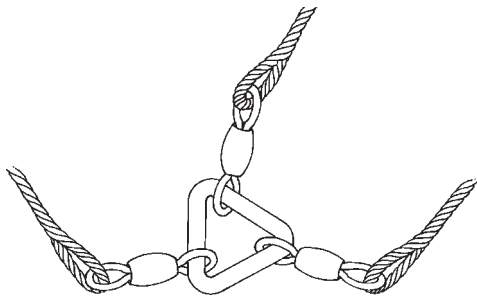

Three-way swivel

The trip-line can be made of lighter rope than the anchor line since it is not intended to take the weight of the boat. The line should be rigged with a small float to keep it at the surface where it will not interfere with the sea anchor. It should also have a sinker at the end which is attached to the parachute's vent strap, to make sure the parachute stays well below the water surface. If possible a 3-way swivel should be built into the line between the connections to the float, sinker and vent strap in order to minimise tangling. If a 3-way swivel is not available, the float can be connected directly to the vent strap using a length of light chain.

SETTING AND HAULING

The procedure for deploying a sea anchor is as follows:

- check the shrouds are free to run and not tangled;
- connect the anchor line, swivel and shrouds together;
- attach the trip-line to the vent strap, then to the float and sinker ropes;
- attach the float to the trip-line, and then the haul-in line to the float;
- lower the trip-line, float and sinker into the water from the bow of the boat, while the helmsman uses the engine to hold the boat facing into the wind;
- lower the sea anchor into the water, vent section first, then the rest of the parachute, then the shrouds;
- while holding onto the base of the shrouds, have the helmsman reverse the vessel gently away from the parachute to assist in opening it up;
- when the sea anchor has begun to open, carefully lower the dome swivel into the water making sure it does not fall among the shrouds and tangle with them;
- as the sea anchor opens up and the vessel falls away from it, pay out the desired amount of anchor rope and haul-in line, until the vessel is well clear of the sea anchor;
- make sure the weight is being taken by the the anchor line and not the haul-in line, then tie them both off.

The following steps are carried out when hauling the sea anchor:

- while using slight forward throttle, recover the haul-in line to reach the trip-line, and pull in the float;
- recover the trip-line and haul it in. This will cause the parachute to invert itself and begin to close up;
- pull in the parachute, release vent first, allowing the water to spill out;
- once the body of the parachute is on board, pull in the shrouds, taking care that they do not get entangled;
- disconnect the sinker, swivel and float in the reverse order to that in which they were deployed;
- haul in the anchor line;
- store inside a canvas bag for future use.

When hauling the sea anchor, make sure the wind does not get hold of it, especially if a real parachute (as opposed to a commercial or home-made sea anchor) is being used. The force of a fully inflated cargo parachute in a strong wind can be very powerful and can cause an accident.

CHAPTER 2

VERTICAL LONGLINING

- A. BASIC GEAR CONFIGURATION
- B. THE MAINLINE
- C. BRANCHLINES
- D. OTHER GEAR AND EQUIPMENT
- E. SETTING THE LINE FROM A BASKET
- F. SETTING THE LINE FROM A SAMOAN HANDREEL
- G. SETTING MULTIPLE LINES
- H. HAULING THE LINE
- I. TARGETING FISH CONCENTRATIONS
- J. FISHING WITH A SEA ANCHOR
- K. GEAR CARE AND MAINTENANCE
- L. SCALING UP THE FISHING OPERATION

INTRODUCTION

This chapter describes the gear and techniques used for vertical longline fishing. The first few sections describe the materials and construction methods needed for making the longline and its various components. The next part of the chapter concentrates on the basic fishing method—different ways of setting single and multiple lines and the techniques for hauling them after fishing. The last part of this chapter describes more advanced aspects of fishing, such as ways to get the fishing gear close to the concentrations of fish around FADs, the use of a sea anchor for vertical longline fishing, care and maintenance of the fishing gear, and the prospects for moving up to use larger-scale equipment.

SECTION 2A: BASIC GEAR CONFIGURATION

Schematic diagram of typical vertical longline fished from a surface float

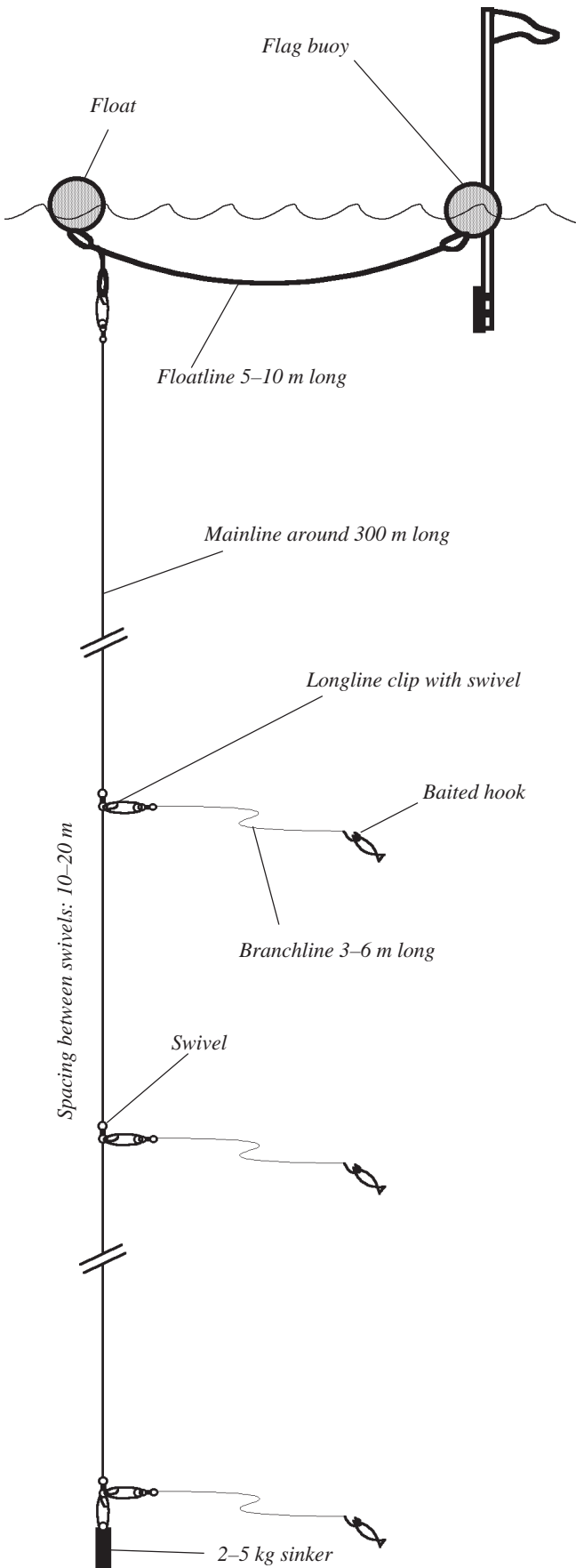

Vertical longlining is a simple and relatively cheap way to fish in deep water for tunas and other oceanic fish. It is particularly suitable for fishing around FADs but can be used anywhere where tunas are found.

A basic vertical longline comprises a single long weighted mainline suspended from the surface and which reaches down to a depth of 300 m or more. Connected to the mainline are a series of branchlines (sometimes also called snoods or leaders), each of which carries a baited hook. The branchlines are attached using longline clips to swivels which are built into the mainline at intervals of 10-20 m.

There are numerous styles of fishing using vertical longlines. The lines may be fished from a basket or bin, or can be wound onto a fishing reel. The wooden Samoan handreel, widely used in the Pacific, can be used when the mainline is made from nylon monofilament.



Vertical longline being fished directly from the vessel

Alternatively, larger-scale drums can be fabricated to allow fishing of more lines, or the use of heavier line materials. The vertical longline can be fished from the boat or FAD, or can be buoyed off and allowed to drift free. The lines may be set float-first or sinker-first. Depending on the circumstances, it may even be possible to fish several vertical longlines in a string, connected to each other by long floatlines.

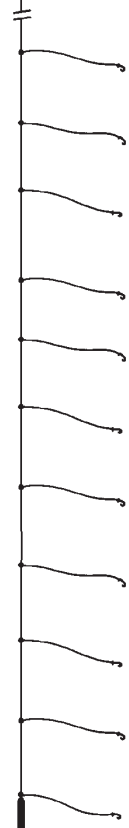

As well as the fishing style, the gear itself may also vary in its details, for instance in the length of the mainline and the number and spacing of the branchlines (and thus their fishing depth range). Specific local circumstances, such as the depth at which fish are found to be biting and the type of materials available, may prompt variations in the gear used and the detailed design of the line.

Personal preference is another major factor in gear selection and design. Some fishermen simply prefer handling kuralon over nylon monofilament, or find that fishing from a Samoan handreel gives them backache and so prefer to fish from a basket and hand-haul the lines. Others prefer to use two or three small floats at the head of the line, instead of a single large one, because it makes it easier to see when there is a fish on the line.

Despite the variations in detail, the principles that apply to making up the gear are standard. Once fishermen become familiar with the basic gear rig and fishing procedure, adjustments can easily be made in response to the fisherman's individual needs.

The table below provides specifications of the materials typically needed to make up a single vertical longline with a 300 m mainline and 15 hooks and branchlines spaced at 10–20 m intervals. The table below is intended as a guide, and not necessarily a specific recommendation. The materials listed in the table are suitable for the construction of a good-quality vertical longline, but equally good alternatives are available for many of them.

Component	Typical materials	No./Amount
Surface float	Plastic longline float 300 mm diameter	2
Marker buoy	Bamboo or fibreglass pole	1 x 3 m length
Floatline	Polypropylene rope 6–8 mm dia. or Kuralon longline rope	1 x 5–10 m length
Mainline	Monofilament nylon, 200–500 kg test or Kuralon longline rope	1 x 300 m length
Swivels	McMahon Heavy Duty, size 10/0–12/0 or leaded swivels	15
Branchlines (each 3–6 m long)	Nylon monofilament, 125–250 kg test (breaking strain should be at least 50 kg less than that of the mainline)	15 x 3–6 m lengths
Longline clips	Size 1–12 cm longline clip with swivel	15
Hooks	Mustad tuna circle size 14/0, 15/0 or 16/0 or BKN size 48 or Japan tuna hook size 3.6 mm	15
Sinker	Lengths of rebar 2.5 cm dia x 22–40 cm long, tied or welded together to make weights of 2–5 kg	6 pieces

The choice of which options a fisherman follows will depend on local availability of materials, fishing conditions, and his own personal preferences. The rest of this chapter provides more detailed information on many of these options, including making up the gear, basic fishing styles, and more advanced fishing strategies that may be followed by someone who finds vertical longlining to his liking and wishes to scale up the fishing operation.

SECTION 2B: THE MAINLINE

LINE MATERIAL

There are two widely-available choices of material for the mainline: **nylon monofilament** and **longline rope**.

- if **nylon monofilament** is used it should be at least 200 kg test breaking strain, although up to 500 kg test can be used if local circumstances or availability dictate. 200-kg or similar monofilament is widely available, and fairly cheap. The slipperiness of nylon makes it difficult to hand-haul and it will easily tangle if fished from a bin or basket, but it is compact enough to be fished from some types of fishing reel, such as the Samoan handreel (see section 2F).
- **longline rope**, which is made of a nylon material called Kuralon, is heavier and bulkier than nylon monofilament and cannot be fished from a Samoan handreel, although larger reels can be made to accommodate it. However Kuralon is easier to grip when hand-hauling and is less liable to tangle when fished from a basket. Although new Kuralon is expensive, second-hand material can sometimes be obtained cheaply in places where industrial longliners operate.

Irrespective of which material is used, the basic design of the mainline is the same. The line is divided into a number of parts: a long ‘leader’ section which runs from the surface to the first swivel, and then a number of shorter equal-length sections which separate the rest of the swivels. The swivels will serve as the attachment points for the branchlines (see section 2C). Once the line has been rigged up, the fishing depth can be changed by shortening or lengthening the first section of mainline, that is, the section from the surface to the first swivel.

Design example for a 300 m mainline with 15 branchlines

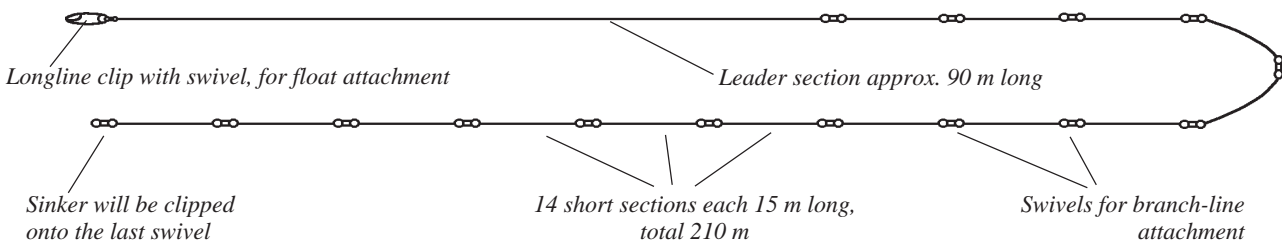

Some fishermen prefer a variation on this design: they incorporate swivels all the way along the line, so that, effectively, there is no leader section. This arrangement uses more swivels but has the advantage that the line can be used either way up, so that it does not matter which way the line is stored on a handreel or laid out in a bin. This variation is particularly useful if the lines will be set float-first from a wooden handreel, as described in section 2F. In addition, this system allows the fisherman to get more hooks in the water, and to target shallow-water species such as mahi mahi, sailfish and marlin if these are present in the fishing area.

‘Reversible’ mainline design, total length 300 m

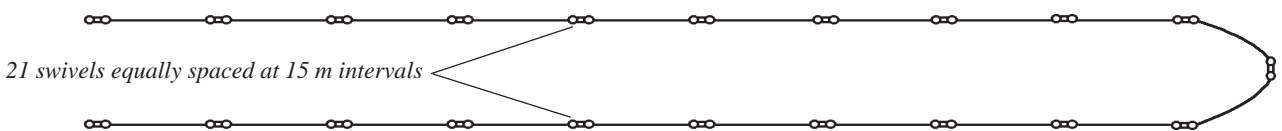

SWIVELS

Swivels are built into the mainline at regular intervals, typically every 15 m. The swivels serve two purposes; they provide secure attachment points for the branchlines and they allow sections of the mainline to rotate independently, reducing the likelihood of the mainline and branchlines tangling with each other.

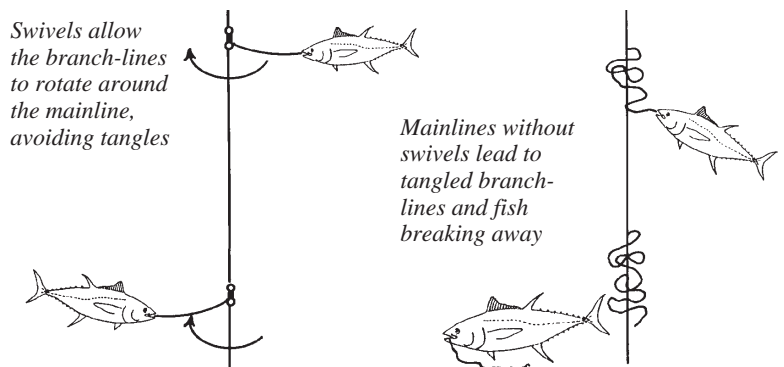

Heavy duty swivels made of brass or stainless steel should be used. Brass barrel swivels function almost as well as stainless steel ball-bearing swivels and are available at a fraction of the cost.

Swivel types

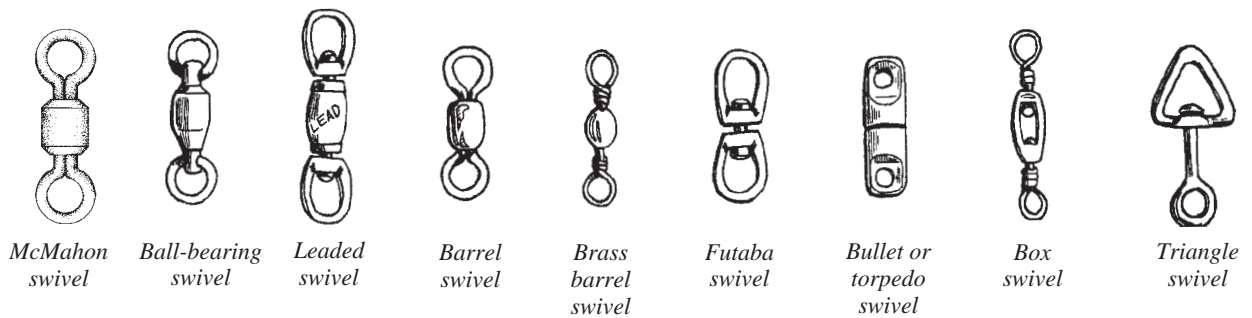

ATTACHING THE SWIVELS

There are two basic methods for building swivels into the mainline using the knots, splices and other line-connection techniques described in sections 1E–1H:

Free-running

One eye of the swivel is threaded onto the line, allowing it to slide free. The swivel is kept in the right place by blocking its movement using stopper knots or crimps. This method creates a 3-dimensional swivel arrangement by allowing the swivel to rotate both horizontally and vertically.

Stopper knots are difficult to tie in monofilament, since the knots tend to be too small to prevent the swivels sliding over them. Crimps are therefore needed if nylon is being used for the mainline, and this will add extra cost to the line. If Kuralon is being used, a simple overhand or figure-of-eight knot will be large enough to stop most swivels.

Free-running swivel arrangements

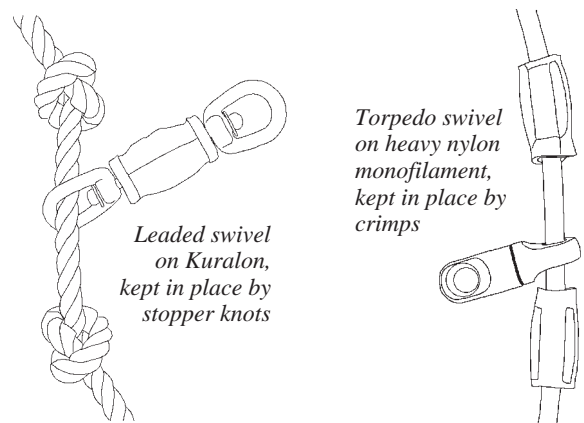

In-line swivel arrangements

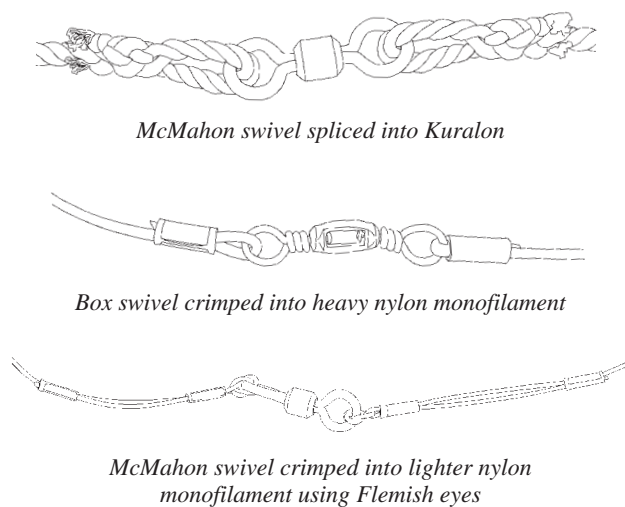

Tied-in, or 'in-line'

This is the most common method. The line is cut into sections of the appropriate length and the ends of each section are then fixed into the swivel eyes using knots, splices or crimps. This does not allow as much freedom of movement for the swivels as the free-running method unless 3-way swivels can be obtained. However this technique may be necessary if the mainline is made of monofilament and crimps are not available.

Clinch, slip or trilene knots, or crimps, are suitable for connecting the ends of monofilament sections, braided lines or other lighter lines into the swivel eyes. For Kuralon or other 3-strand materials an eye splice is the best option: tying a bowline knot is a lot faster but is weaker than a splice. In addition the knots will snag and tangle if the line is fished from a basket, and may also hook up on and tangle with the branchlines.

Which system is used will depend on the material from which the mainline is being made, the relative availability and cost of labour and materials, and the personal preference of the fisherman who owns the gear.

SECTION 2C: BRANCHLINES

LINE MATERIALS

Branchlines consist of a length of nylon monofilament with a hook at one end and at the other a longline clip (sometimes called a snap) fitted with a swivel. The monofilament used should be of a lesser breaking strength than the mainline. If 200 kg test monofilament is used for the mainline, then branchlines should be made from 125–150 kg monofilament.

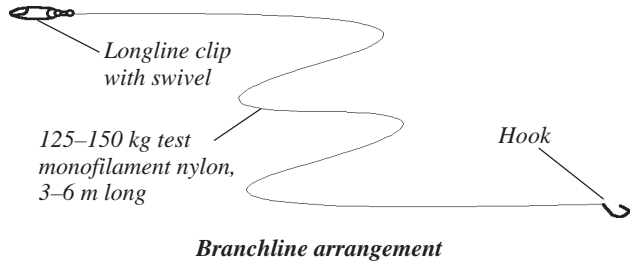

The length of the branchlines should be a bit less than half the distance between swivels in the mainline. For instance if the swivels are spaced 15 m apart then the branchlines should be less than 7.5 m long. Restricting the length of the branchlines in this way helps prevent them from tangling with each other.

Length of branchlines should be kept to less than half the distance between them...

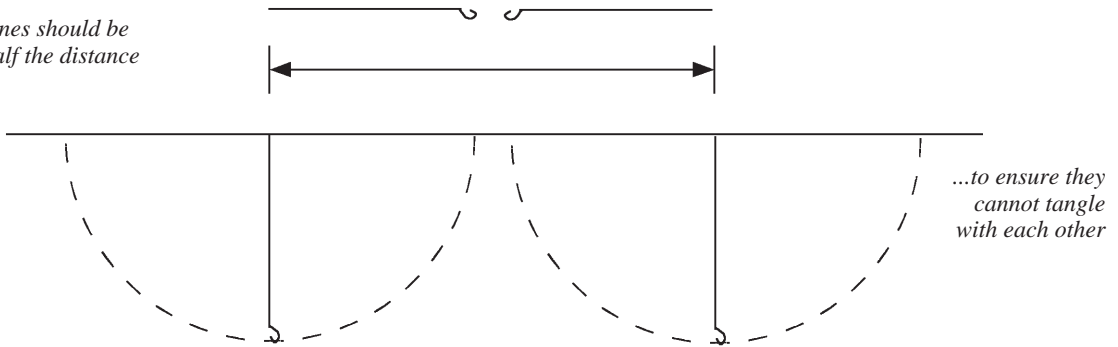

CLIPS AND HOOKS

Longline clips

Standard longline clips or snaps are used for connecting branchlines into the swivels on the mainline. A range of sizes are available: the size should be selected so that the clip will fit the mainline swivel or other attachment system being used (see next page). Clips with a length of 10–12 cm are usually a good choice.

Some longline clips come fitted with a swivel in the base: these types are better than those with no swivel.

Choose 10–12 cm longline clips with swivels...



...or, if unavailable, without swivels

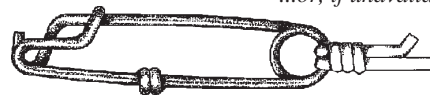

Hooks

The best types of hooks to use are size 14/0–16/0 Mustad tuna circles, size 48 Tankichi BKN tuna longline hooks, or 3.6 mm Japan tuna hooks. These hook styles have a circular hooking motion which is adapted to the way a tuna takes the bait. Tuna circle and Japan tuna hooks are available in stainless steel versions which are more costly than the standard galvanised types but last longer. If circle hooks are unavailable a range of other straight hook types can be substituted, but they will probably result in fewer hook-ups.

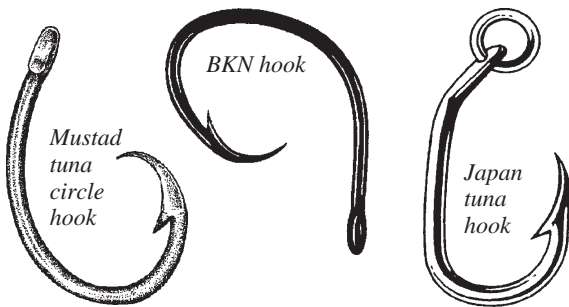

Attaching hooks and longline clips

Hooks and longline clips are attached to branchlines using crimps, or by knotting using one of the monofilament knots shown in section 1H.

ATTACHING BRANCHLINES TO THE MAINLINE

Direct attachment

If three-way swivels or sliding swivels are being used on the mainline, the longline clips on the branchlines can be attached directly into them (provided of course that the clip is the right size to pass through the swivel eye). This provides a secure attachment for the branchline while also allowing it to rotate in both horizontal and vertical dimensions. If the longline clip is also fitted with a swivel at its base then the branchline will be very well protected against tangling and cut-offs.

If standard 2-way swivels have been used in the mainline, the branchline can still be clipped into the swivel eye (normally the lower, for reasons that will be explained later). In this case the connection is secure but somewhat stiff, and limits the rotation of the branchline to the horizontal dimension only. Even this rotation will be impeded somewhat by the weight of the mainline on the swivels, so it is important to make sure that longline clips with built-in swivels are used in this arrangement.

Attachment rings and double swivels

Any of these attachment methods requires that the size of the mainline swivels and the longline clips are matched to each other—sometimes an impossibility in places where gear in a range of sizes is hard to obtain. In addition, clipping and unclipping snoods from certain types of swivels can be awkward and difficult to do quickly.

When this problem is encountered, an option is to fix attachment rings into the swivels, or to use a double swivel arrangement. A simple way of doing this is to splice small loops of Kuralon into the swivel eye. This allows for fast, easy attachment of the longline clips.

Alternatively a sturdy stainless steel spring washer can be fitted through the eye by opening and closing it using two adjustable wrenches.

If the eye of the swivel is too small to attach a longline clip or an attachment ring, it may be possible to use a double-swivel arrangement. Some types of swivels can be purchased with the eye of one swivel threaded through the eye of another.

Fitting the mainline swivels with an attachment ring makes it easier to clip the snoods on and remove them, and the connection is quick and flexible rather than awkward and stiff. The drawbacks are that the attachment rings add bulk to the line, and must be regularly checked and replaced as they become worn, especially in the case of Kuralon loops.

Branchline attachment methods

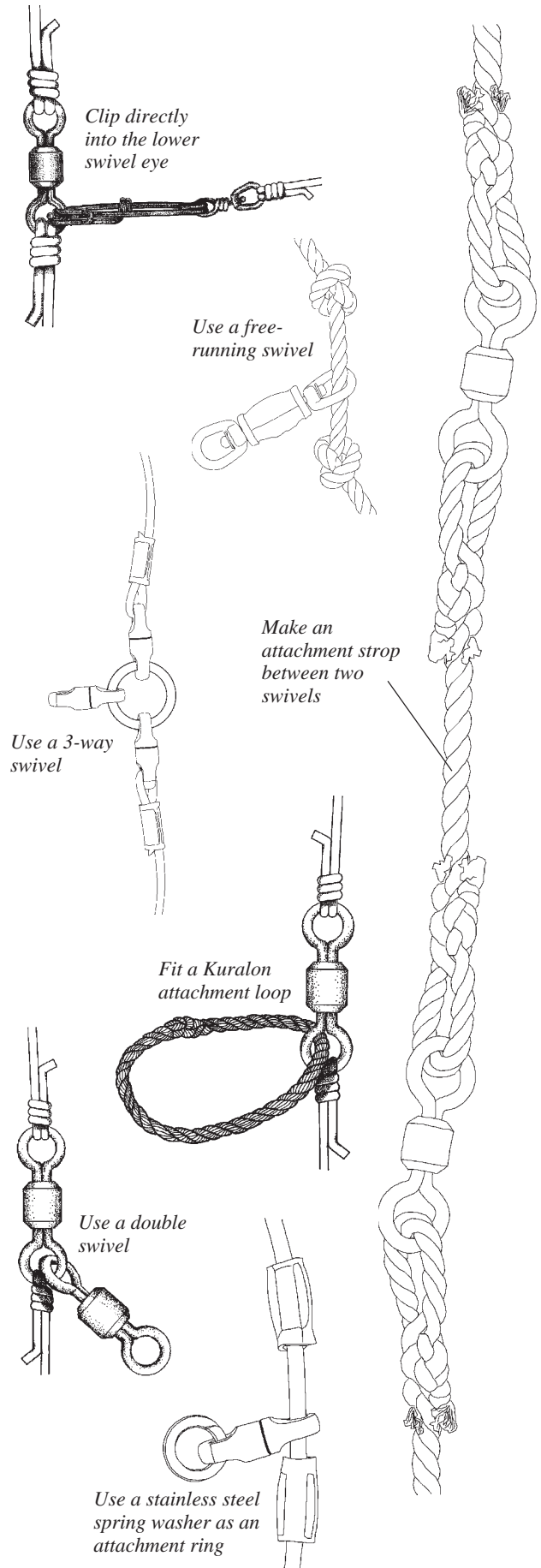

SECTION 2D: OTHER GEAR AND EQUIPMENT

BRANCHLINE STORAGE

During the fishing operation, a systematic approach to the storage and handling of branchlines is needed if they are not to finish up as a tangled mess.

For small numbers of branchlines, the best storage method is to wind them onto a handcaster spool or other cylindrical object, such as a large-diameter plastic bottle. Alternatively, if the boat is using Samoan handreels (see section 2F), one handreel can be used to store the branchlines while the mainline is fished from another.

The hook of the first branchline is hooked into a hole or groove made in the spool for this purpose, and the branchline wound on. When the longline clip is reached the hook of the next branchline is hooked through the clip and winding continues so that the next branchline is wound on the spool. The process continues until the spool is full. Normally one or two large handcasters are enough to hold all the branchlines for a single mainline.

Branchline storage

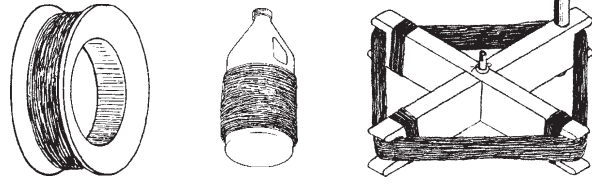

Store small numbers of branchlines on handcasters, large plastic bottles, or a Samoan handreel spool

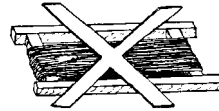

Avoid small-diameter rectangular frames, which will kink the branchlines

Storing branchlines in a box

The hook of the branchline is passed through the swivel or eye of the longline clip...

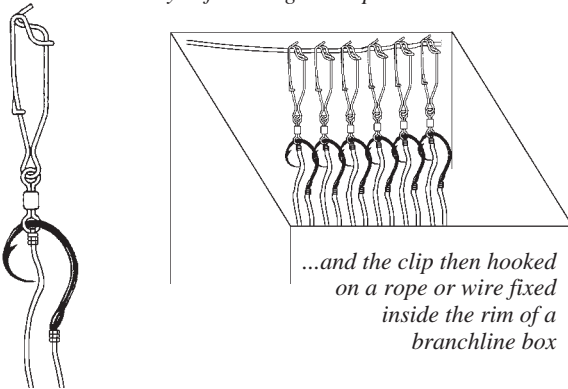

...and the clip then hooked on a rope or wire fixed inside the rim of a branchline box

For larger numbers of branchlines, a box or bin is more practical. A length of nylon monofilament is attached inside the rim of the box using U-nails, staples or tie-wires. For storage the hook of each branchline is hooked through the swivel or eye of its own longline clip. The clip is then attached to the nylon line inside the rim of the box, and the body of the branchline placed in. To avoid tangling the clips are attached to the line in careful sequence, starting from one corner or specific place marked on the box and working around the edge. The last branchline clipped in place will have its line on top of the pile and so should be the first one to be taken out of the box when fishing commences. As long as the order of storage is kept systematic, and the 'last-in-first-out' rule is followed, the branchlines should not become tangled.

FLOATS AND SINKERS

Standard 300 mm diameter hard plastic longline floats are suitable for vertical longlining. A short loop of Kuralon fitted with a longline clip should be tied or spliced to each float to allow quick attachment and removal. The floats are generally not clipped directly to the mainlines. Instead, both the float and the mainline are clipped onto loops, or swivel eyes, in a section of polypropylene floatline, as explained opposite.

Instead of a single larger float, two or three smaller floats connected in a short string can be used. This is more costly and cumbersome but when a fish is hooked it can be seen more easily due to the submersion of the first float in the string. It also acts as a shock absorber when a fish strikes or makes a run after being hooked.

Scrap lengths of steel reinforcing rod (rebar) are commonly available and can be used to make sinkers. Use 4–6 pieces of 20–40 cm length rebar to make 2–5 kg sinkers by welding the pieces together or binding them with nylon monofilament offcuts or lengths of old inner tube rubber. To allow quick attachment and removal, a longline clip is fitted to each sinker using a simple Kuralon or monofilament bridle.

Floats and sinkers

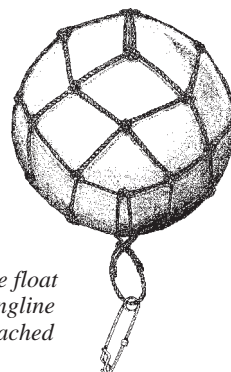

Plastic longline float with longline clip attached



Sinker made by tying together lengths of rebar

FLAG BUOYS

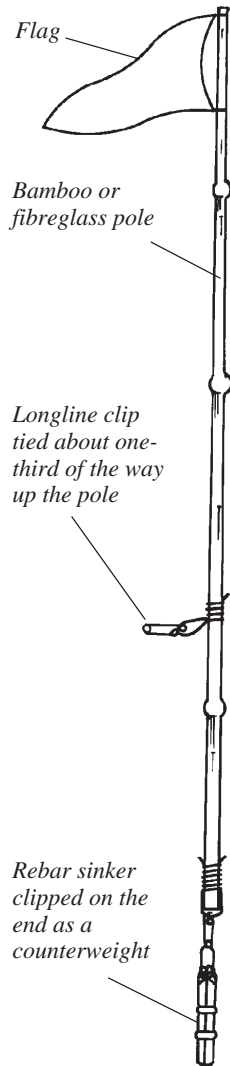

A 3 m length of bamboo or a fibreglass pole is ideal for attaching a flag to a float so it can be seen from a distance. A longline clip is tied to the pole about one-third of its length from the bottom so that it can be clipped to a float. At the bottom end a counterweight comprising the standard rebar sinker is attached to keep it upright in the water. Some fishermen prefer to fix the sinker or float permanently to the flagpole, while others prefer to use longline clips so the sinker and float can be removed for convenience in storage.

FLOATLINE

Floatlines are used to join one or more floats at the surface. They should be made from sections of 6–8 mm diameter polypropylene rope or Kuralon longline rope. When fishing single vertical longlines, a short floatline of 5–10 m in length on each line is sufficient. The function in this case is to make retrieval of the mainline easier, as well as to allow backup flotation to the principal float. If multiple vertical longlines are being fished (see section 2G) then longer floatlines or extra rope sections, 60–100 m in length, can be used to keep the mainlines well separated and avoid tangling.

A basic floatline is just a length of rope with an eye splice (see section 1F) in each end. However a better system is to give each floatline a two-eye end and a one-eye end. To rig this, an eye is first spliced into each end of the floatline. Then, about 2 m from one end, an extra 1-m length of rope, with another eye-splice already made in the end, is spliced in. This extra 'hanging loop' is used as the attachment point for the mainline, while the two end-splices are used to attach the float and flag buoy respectively.

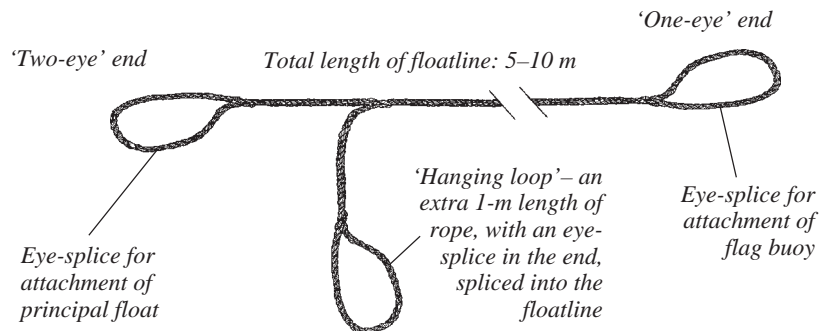

This is not the only floatline system that can be used, and most fishermen have their own favourite way of clipping or tying the mainline to its floats and floatline.

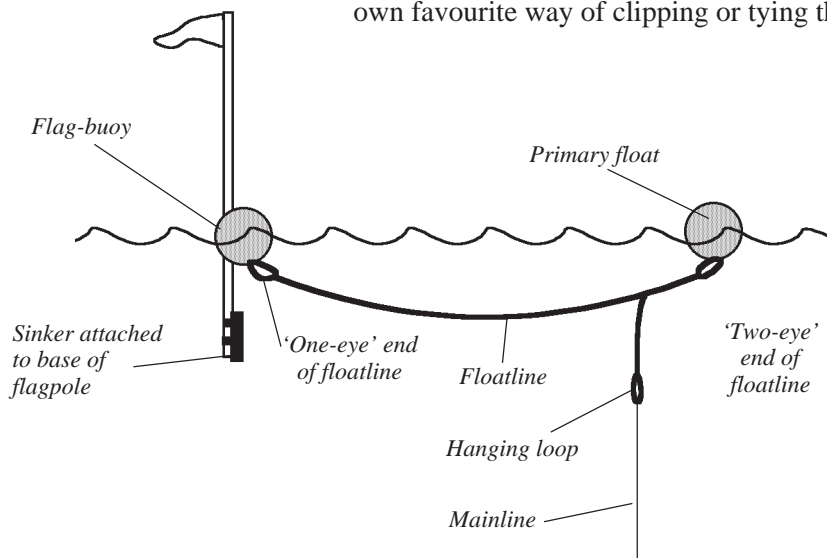

Floatline arrangement

When fishing a single mainline, one floatline is used. The mainline is clipped to the eye-splice of the hanging line, at the 'two-eye' end of the floatline, while a float without flagpole is clipped to the other eye-splice at the 'two-eye' end. The flagpole buoy is clipped to the eye-splice in the 'one-eye' end of the line.

SECTION 2E: SETTING THE LINE FROM A BASKET

This section describes the basic procedure for setting a vertical longline from a basket. Section 2F describes fishing with a wooden hand-reel, and section 2L briefly discusses the use of a larger longline drum. Setting multiple vertical longlines is described in section 2G, and hauling the lines in section 2H.

GEAR

Fishing from a basket is the cheapest and simplest way to carry out vertical longlining. The line is stored in a basket or bin and is set and hauled by hand. Because of its slippery nature and its tendency to tangle, nylon monofilament is not very suitable for basket-style fishing. The best material is Kuralon longline rope, or alternatively a strong braided line made of a material such as dacron which is easy to grip and which sinks.

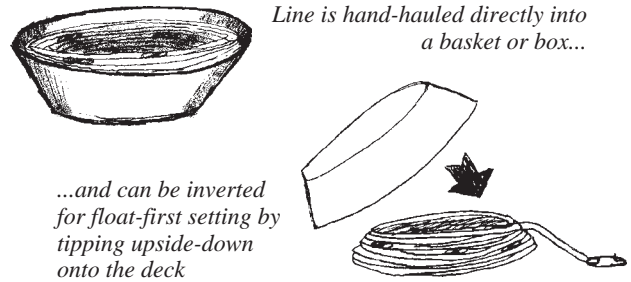

When the gear is hauled in after fishing, the mainline is coiled into the basket or bin for storage. Since hauling always starts from the float, this means that the top end of the line goes into the basket first, and the bottom (sinker) end of the line finishes up on top of the pile. If the line is to be set sinker-first (see opposite page) this is not a problem as the sinker end is the first to be deployed. If the line is to be set float-first then the line needs to be reversed before it can be set. This is done by turning the basket over and dumping the line onto the deck in an upside-down pile, so that the float end is now on top. Alternatively, a 'reversible' mainline with swivels along the entire length (see section 2B) can be used, in which case there is no need to turn the line upside down before setting float-first.

BASIC PROCEDURE

Irrespective of whether the line is set sinker-first or float-first the basic setting procedure is the same. The mainline is paid out over the side of the boat by one crewman—the 'line-man'—at a speed which allows a second crewman—the 'bait-man'—to clip on the branchlines as the mainline goes by. Normally a third crewman is responsible for driving the boat.

The line should always be set from the part of the boat which will avoid the line and the boat being pushed together by the action of current or wind. Which part of the boat this is will vary depending on the direction and strength of wind and current, and whether the boat is under way, drifting, or tied to a FAD.

While the line-man pays out the mainline at the correct speed, the bait-man takes a branchline and throws the baited hook over the side while holding onto the longline clip at the other end. Baiting may be done during the setting operation, or it may be preferred to save time by baiting all the hooks before setting begins. Once the hook is in the water, the branchline is clipped into the appropriate swivel eye or attachment ring on the mainline. The procedure is repeated, with baited branchlines being clipped onto the swivels as they appear, until all the hooks have been set.



The bait-man throws the bait well clear of the boat...

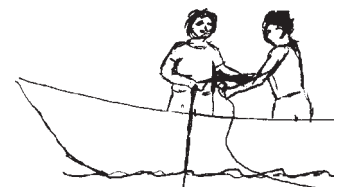

...before attaching the branchline to the mainline

For safety reasons **the baited branchline is never clipped onto the mainline until the hook is in the water.** This is to avoid injuries that might be caused if a large fish bites on a hook which is already in the water while the bait-man is still holding a connected-up branchline in his hand.

SETTING SINKER-FIRST OR FLOAT-FIRST

As mentioned previously, vertical longlines can be set **sinker-first** or **float-first**. Sinker-first setting takes longer but can be done when the boat is drifting or tied to a FAD. Float-first setting is faster but is only really practical while the boat is under way.

Setting sinker-first

The sinker is clipped onto the swivel or attachment point at the bottom of the mainline, and the line lowered slowly over the side by the line-man while the bait-man clips a branchline onto each swivel as it goes by. The line should be paid out slowly, otherwise the branchlines will stream upwards and may tangle with the mainline. If there is a strong current which keeps the branchlines clear of the mainline, then setting can be sped up a little, but if the current is weak then the line should only be lowered at the same rate that the baits sink naturally. Having to lower the line so slowly makes the sinker-first method rather time-consuming, with about 10–15 minutes needed to set each line.

Alternatively the line can be buoyed off from the boat, or set free to drift, so that more lines can be set. Fishing with multiple lines is described in more detail in section 2G.

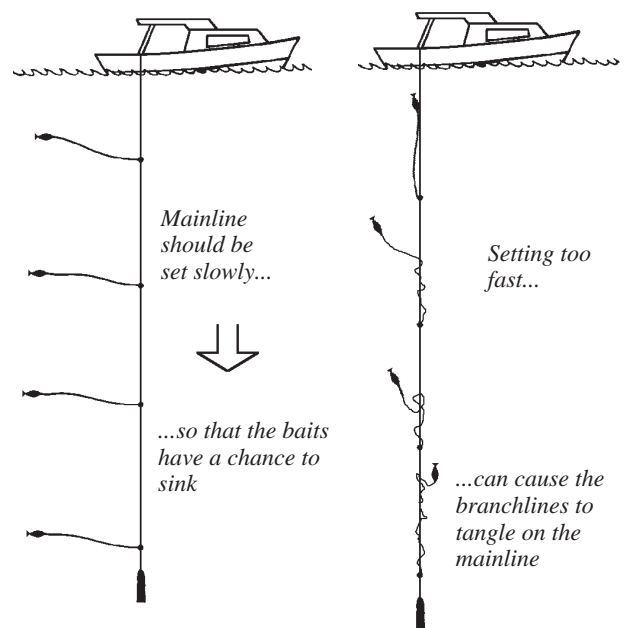

Setting float-first

Float-first setting is the reverse of the above procedure. It allows faster deployment of the gear as the vessel's engine is used to accelerate the setting process. This method is most suited to setting single vertical longlines, and is impractical when setting strings of lines.

The floatline is prepared first by attaching a flag buoy to the one-eye end and a primary float to the two-eye end as shown in section 2D, and the end of the mainline into the hanging loop on the floatline. The flag buoy is then put over the side with the floatline, the primary float and the beginning of the mainline, as the vessel starts to motor away. The boat continues on course, with the upper section of the mainline now paying out.

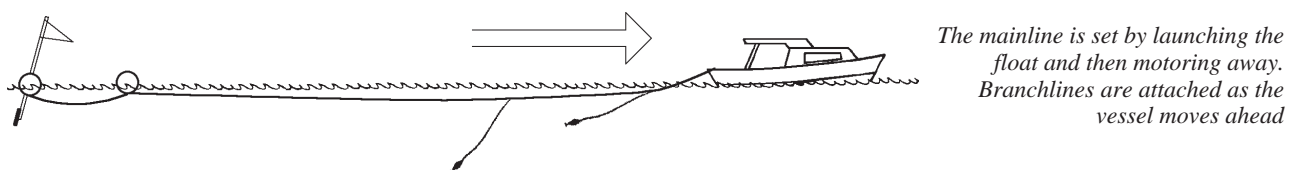

When the first swivel is reached, the vessel slows down to an appropriate working speed so that the bait-man can attach the branchlines as the mainline swivels go by. The boat driver may need to slow down and speed up between swivels. Once the last branchline has been attached, the sinker is clipped on and let go over the side. The whole process should take less than 5 minutes.

Apart from speed, the other advantage of this method is that the entire system is deployed more or less horizontally at the surface and then swings slowly down to its vertical position through an arc with the branchlines streaming behind the mainline. This reduces the chances of the branchlines tangling with the mainline, which is always a risk when the sinker-first method is used.

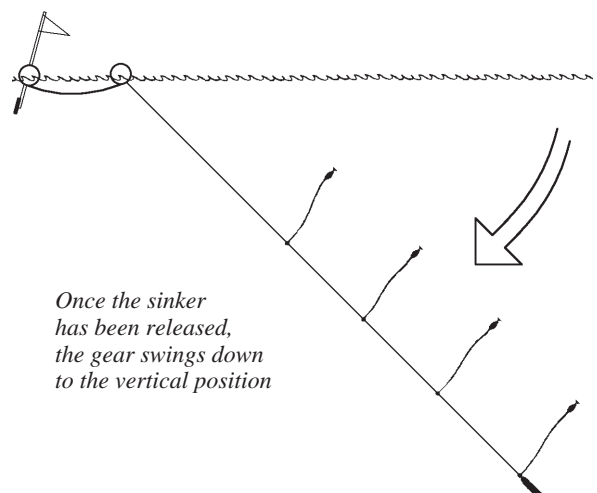

SECTION 2F: SETTING THE LINE FROM A SAMOAN HANDREEL

THE SAMOAN HANDREEL

Because it is easy to rig, inexpensive, and effective when fishing, monofilament nylon is a good material for vertical longlines. However, unlike Kuralon and other rope materials, it cannot be fished from a basket or bin as described in section 2E, because it is too prone to tangling, and too slippery for practical hand-hauling. A reel is therefore needed to operate vertical longlines with nylon monofilament mainlines.

Any type of large fishing reel can be used for this purpose, but the one discussed here is the wooden 'Samoan handreel'. This was introduced into Samoa in 1975 by the Food and Agriculture Organization of the United Nations and has now become widespread in the Pacific Islands region for deep-bottom fishing and trolling. The reel can easily be adapted for vertical longlining and is ideal when only a small number of mainlines are being used. Instructions for building the reel are given in *SPC Handbook No. 25 (1985), Notes on the Construction of the FAO Wooden Fishing Reel*.

The FAO/ Samoan wooden handreel

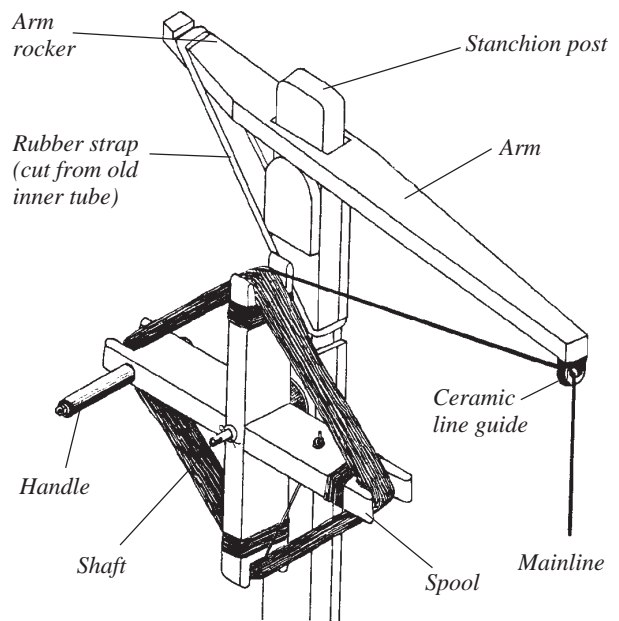

ADAPTING THE REEL

Replacing the line guide

Most Samoan handreels use a ceramic electrical insulator (of a type used on telegraph poles) as a line guide. This is too small to allow passage of many of the larger types of swivel that may be used on a vertical longline. Even if the swivels could pass through, they would soon chip the insulator, which would then damage the mainline. The line guide must therefore be replaced by a large-diameter pulley or block, preferably plastic, that will allow the free passage of the swivels in the mainline. Take care to select one in which the sheave (wheel) is slightly recessed into the walls, so that if the line ever jumps off it will not jam down the side.

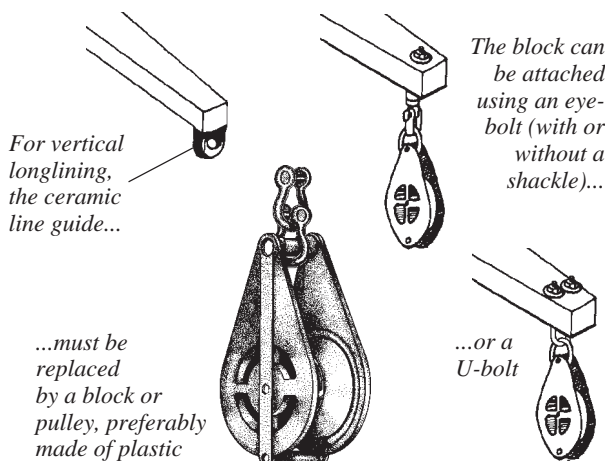

To fit the pulley, dismantle it and fit an eye-bolt over the pin at the top, and then fix this to the correct place on the reel arm. This gives a solid attachment which will not swing from side to side too much, thus keeping the line properly aligned with the handreel during setting and hauling. If the pulley cannot be dismantled, a U-bolt and/or a small shackle can be used instead.

Adding a backing line

In vertical longlining the handreel spool is used for storage, setting and hauling of the mainline. Before winding the mainline onto the spool, however, a backing line made from light rope or heavy monofilament should first be attached. This can be done by tying the backing around the reel, or knotting it through a small hole drilled in one of the reel arms for this purpose. A loop is made in the free end of the backing, or a longline clip attached, and this serves as a connection point for the mainline.

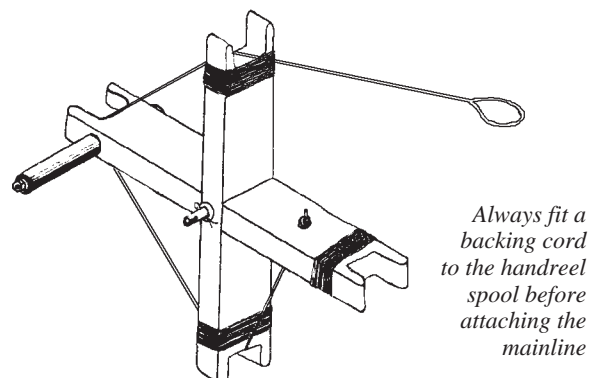

Always fit a backing cord to the handreel spool before attaching the mainline

The mainline should always be properly attached to the backing before being wound onto the reel. This way, when the mainline is unwound during fishing there is no chance that the whole lot will disappear over the side when the end is reached. If it is made fairly long, the backing can also be used to let the line away from the vessel, with a buoy attached, so there is never a need to disconnect the mainline and it can easily be retrieved.

The reel should also be fitted with a braking system to ensure that a large fish making a run will not pull too much line off the reel or cause an injury. A simple loop of inner tube rubber, attached to the side of the boat and looped over the reel handle, makes a simple but effective brake. More elaborate systems have also been devised by some fishermen.

Once the reel is ready for use the mainline can be wound onto it. The type of mainline used (with a leader or reversible, as shown in section 2B) will depend on whether the line is to be set sinker-first or float-first. Depending on the length and diameter of the nylon being used, it may be possible to fit two mainlines on a single handreel spool. In any case the spools can be easily changed over during fishing, so additional mainlines can be stored on spare spools, allowing the fisherman to carry as many lines as he can operate.

SETTING THE LINE

The basic principles of setting the line using the wooden handreel are similar to those outlined in section 2E. As with basket gear, the options exist for setting the line either sinker-first or float-first.

Setting sinker-first

The mainline is threaded through the block or pulley on the reel arm, and then a sinker clipped onto the first swivel at the bottom end of the line, along with the first baited branchline. The line-man lowers the mainline by controlled unwinding of the reel while the bait-man connects the branchlines one at a time as the swivels go past. For safety reasons the baited hook is always thrown into the water before attaching the longline clip to the swivel, as described in section 2E. The line-man lowers the mainline slowly over the side, watching the bait as it sinks to ensure the rate of unwinding is not so fast as to cause tangles. Under no circumstances should the reel be let go and allowed to free-spool—this is a guaranteed recipe for large tangles.

Setting float-first

Setting the line float-first can be done roughly as described in section 2E, using a reversible mainline as shown in section 2B. Normally branchlines would not be clipped onto the first 4–5 swivels, since these will be the ones that end up lying in shallower depths where large tunas would not usually be expected. However if surface-feeding fish such as mahi mahi or small tunas are in the area, it may be worth attaching branchlines to even the shallowest swivels.

Setting is much as described in section 2E. The flag buoy is set first and the vessel motored ahead until the floatline runs out, at which point the primary float is set. Once the mainline begins to run off the reel the vessel needs to be kept at a reasonably slow speed so that the line-man can keep the reel under control. The bait-man attaches branchlines as the swivels go by, taking care to put the hooks overboard before connecting the longline clips.

Once the end of the mainline is reached, the sinker and last baited branchline are attached and dropped overboard, causing the mainline to sink in an arc to its vertical fishing position as shown in section 2E.

A simple handreel braking system

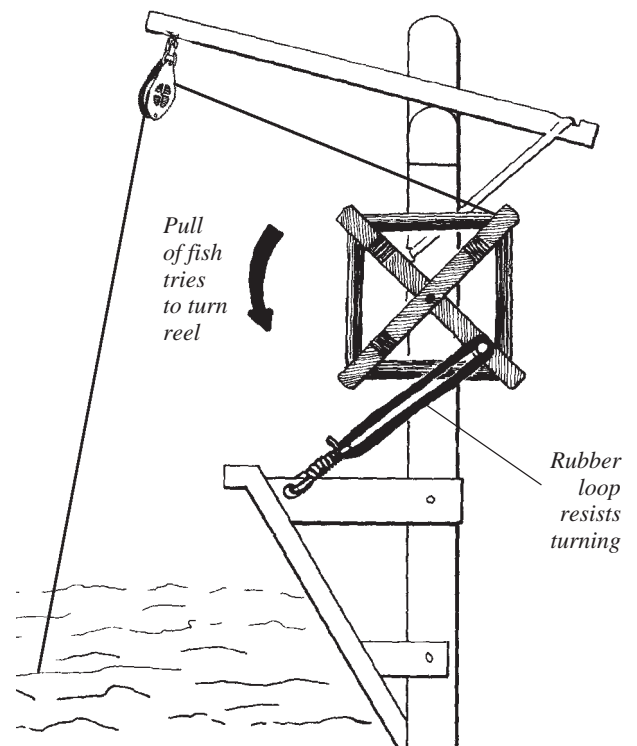

SECTION 2G: SETTING MULTIPLE LINES

STARTING SMALL

The best way to start vertical longlining is to set a single mainline and fish it from the boat so as to become familiar with the gear and the fishing method. When they have been through this stage and become familiar with vertical longline fishing, most fishermen will want to scale up their fishing operation by setting greater numbers of lines. In this case the next step is to start setting free-drifting vertical longlines. If several fishermen are operating in an area, they will need to mark their flags or floats so that each person's gear can be identified.

SETTING LINES TO DRIFT

The float-first setting method, described in sections 2E and 2F, is a quick way to get numerous free-drifting individual lines into the water. The float-first method allows the setting of up to ten lines per hour—probably the maximum that any fisherman would want to set, since once this many lines are in the water it will be necessary to move around checking them and, hopefully, hauling in some fish.

The sinker-first method results in slower setting, but can be carried out without using the engine, so that the boat can fish while drifting or tied to the FAD. When using this method it does not really matter whether the gear is being fished from a basket or from a handreel, although there are some extra precautions to be taken if a handreel is being used.

The first mainline—mainline number one—is set as described in sections 2E and 2F. Once this line has been set, it needs to be got out of tangling distance to make room for mainline number two. To do this a floatline is prepared by attaching a longline float to the eye-splice at the 'two-eye' end, as described in section 2D. Once setting is complete, mainline number one is then clipped onto the hanging loop of the floatline and released, allowing it to drift away from the boat.

If using a handreel, some fishing arrangements require that the mainline be completely disconnected from the reel for a few moments in order to attach it to the floatline. Great care must be taken at this point not to drop the line, otherwise the gear will sink and be lost. Ideally the crew should take a couple of turns of the mainline around a strong point on the vessel or otherwise temporarily attach it to something while the clip is disconnected, just in case a large fish strikes at this exact moment.

Line number one will gradually drift further and further away from the boat. Once the floatline is fully extended, it can be tied off and allowed to fish at a distance, while line number two is buoyed off close to the boat. Alternatively, if more lines are to be deployed, then a flagpole can be attached to line number one and the whole assembly set free to drift. The procedure can then be repeated with line number two, allowing it to drift away while setting of line number three commences. If this procedure is repeated without stopping then it is possible to set three or four drifting lines per hour.

Setting vertical longlines to drift free

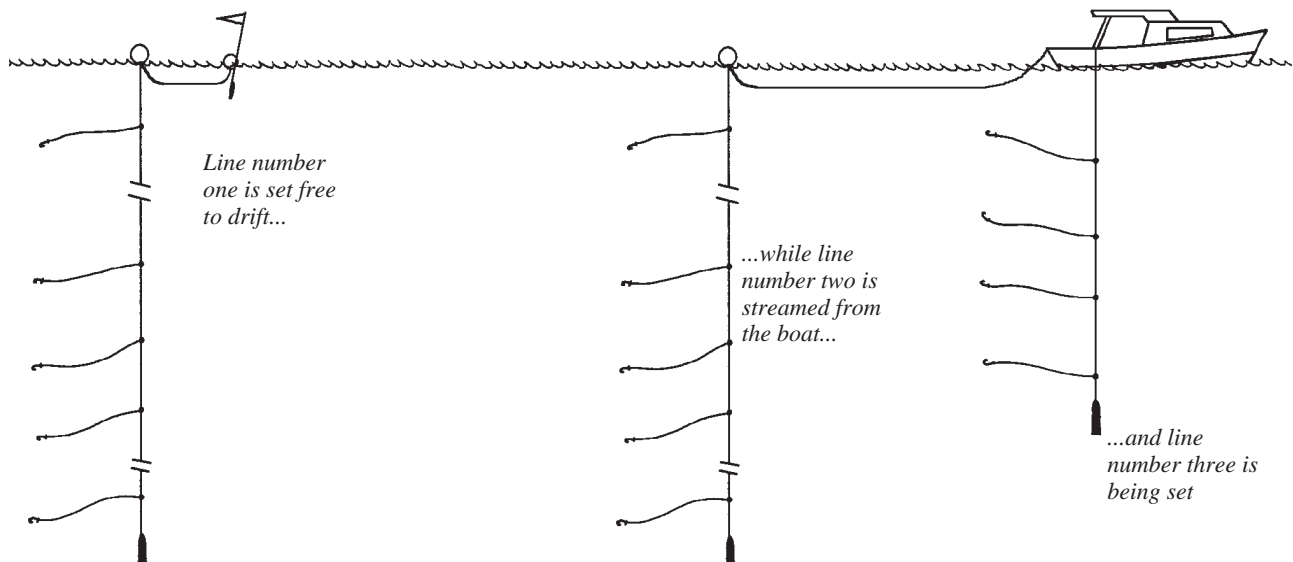

SETTING LINES IN STRINGS

Although setting of numerous individual lines can be done quickly if the float-first method is used, there are some disadvantages to this technique. The lines drift independently of each other and the vagaries of wind and current, plus the movement of hooked fish, will cause the lines to move at different speeds and, sometimes, even in different directions. This makes it hard to keep track of the individual lines, so more time is spent looking for them in order to retrieve them, and there is always the prospect that some lines will be lost.

An alternative to allowing the lines to drift individually is to connect them together in strings, preventing them from drifting too far apart. To do this, instead of line number one being set free, it is attached to line number two by tying a sheet bend (see section 1G) between the ends of the two floatlines. It may be necessary to use longer floatlines (up to 100 m) or to add extra lengths of rope between the floatlines so that the mainlines are well separated (at least 60 m apart) and not at risk of tangling with each other. Once the two floatlines are connected, a float is clipped on and the assembly allowed to drift away.

To connect the two floatlines...

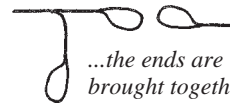

...the ends are brought together...

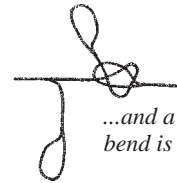

...and a sheet bend is made

The float is then attached to the eye-splice protruding from the sheet bend...



...and the mainline clipped into the hanging loop

The result is two lines fishing while tied off in sequence from the boat. Additional lines can be connected to the end of the string, which can either be left tied to the vessel or can be detached once a sufficient number of lines have been strung together.

A free-drifting string of vertical longlines

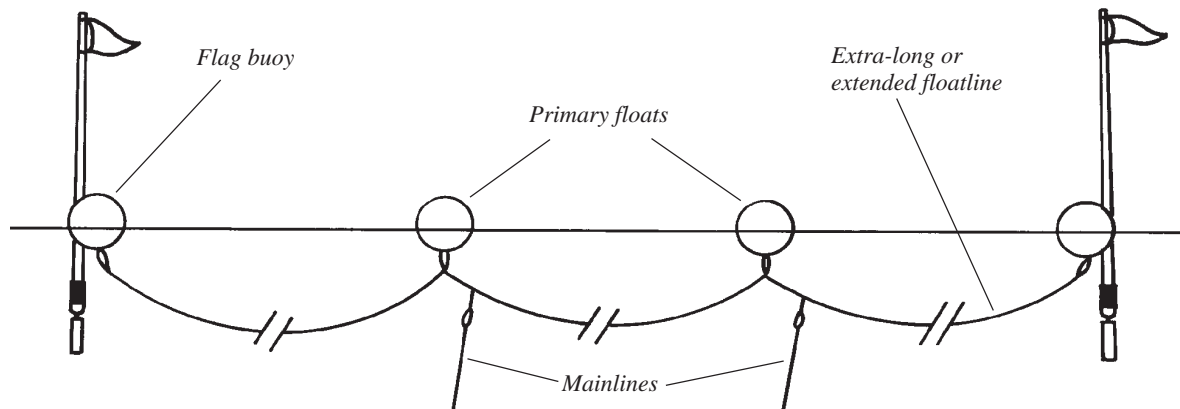

Normally strings of lines are set using the sinker-first method. Technically it should also be possible to set strings using the float-first method, but this would require motoring the boat back to the float of each line after it had been set in order to connect the next line to it. Since this rather defeats the object of the float-first method, whose main advantage is speed, this technique does not actually appear to have been used.

PROS AND CONS OF STRINGS

Setting lines in strings has both advantages and disadvantages. On the positive side, the lines stay together and are a lot easier to find and quicker to haul. In addition, if the fish are concentrated in a small area—for instance, huddled around a FAD or on top of a seamount—then stringing the lines together keeps the hooks in a tighter area and may increase the catch. However there is more chance of the lines tangling with each other, especially in rough weather, or if a large fish or shark is hooked on one line and decides to go for a swim among the others. In addition, while an individual line drifting into and tangling with the FAD is bad enough, a string of lines tangling with the FAD is a disaster which can result in the loss of most or all of the fisherman's gear.

In general, therefore, while it is important to know the method of stringing mainlines together, it is also important to understand the limitations of the technique. Strings of mainlines may improve the efficiency of fishing in calm weather when currents are not too strong and the lines will not be set too close to a FAD. They are also practical when tied to the FAD itself, as the current tends to keep them well separated and helps avoid any tangles. At other times it may be better to set the lines individually, even if this means more time spent retrieving them.

SECTION 2H: HAULING THE LINE

As explained in the preceding sections, vertical longlines can be set in a number of different ways. However the hauling process is essentially universal since, for obvious reasons, hauling always takes place float-first. The use of reels or a hand-hauling system makes very little difference to the actual hauling procedure.

SOAK TIME

Hauling begins after the lines have soaked for a sufficiently long time (2–5 hours) or when it is obvious that fish have been hooked. In many cases the movement of the floats on the surface will give away the presence of fish on the line. When a fish is hooked it is a good idea to wait for 15–20 minutes to allow the fish to tire itself before hauling. In addition, further strikes may occur during this period, as large tuna usually move around in small groups. Even if no fish appear to have been hooked, the lines should still be hauled for checking every couple of hours.

HAULING PROCEDURE

Recovering the mainline

If the vertical longline is being fished directly from the boat (rather than being streamed out or buoyed off to drift free) then hauling of the mainline can start straight away.

If the gear is being fished from the handreel, as described in section 2F, then the mainline clip is transferred from the floatline to the backing on the reel. As in the setting procedure, great care must be taken not to lose the line if it has to be disconnected, especially if it is clear that there is a fish on it. Once the mainline is securely connected to the reel, the line-man begins winding to recover it. If the gear is being fished from a basket, then the line-man starts hand-hauling the mainline, coiling it into the basket as he goes.

As with setting, hauling should not be done too quickly. If the line is pulled in too fast the branchlines will stream vertically downwards and will tend to tangle or twist around the mainline. The line should be hauled relatively slowly and with as steady a motion as possible.

When the first swivel appears, the line-man stops hauling so that the branchline can be checked. If there is no fish, the branchline is first disconnected and then brought aboard. As with setting, care is taken to ensure that the hook always remains in the water as long as the branchline is attached to the mainline. This way if a fish lower down on the line makes a run, no-one in the boat will get hurt by a trailing hook.

If there is a fish on the hook, the branchline is left connected to the mainline while the fish is gaffed, stunned and boated. Once the catch is safely on board, the branchline can be unclipped from the mainline, unhooked from the fish, and put away.

If the line is to be re-set and the bait is in good condition, it may be put aside with the bait still on the hook (see below). Otherwise the bait is stripped, the hook rinsed and the branchline put away on a handcaster or in a branchline bin as shown in section 2D.

The procedure continues, with branchlines being disconnected until the bottom swivel is reached. Once the last branchline has been removed the end of the mainline is brought on board and the sinker unclipped.

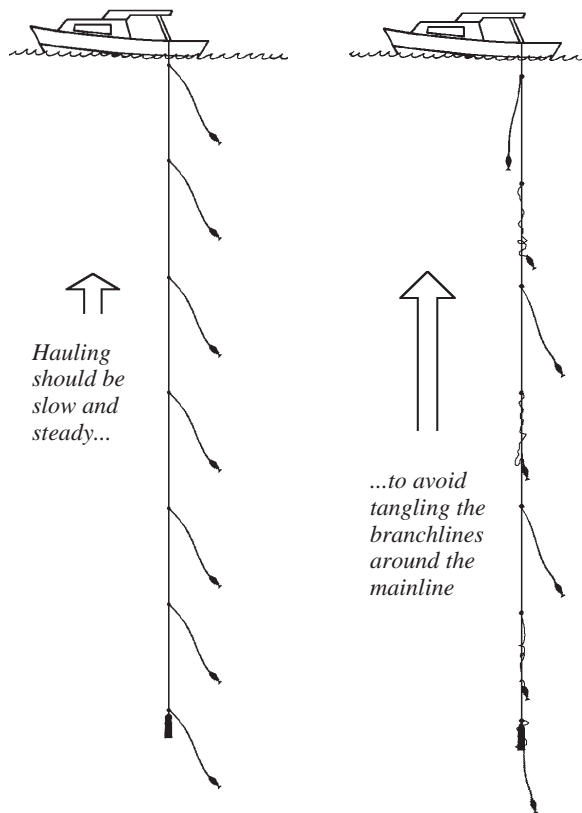

Recovering lines streamed from the boat

If one or more vertical longlines are being streamed from the boat, as shown in section 2G, it is a simple matter to recover them by pulling in the floatlines so they can be hauled one at a time. The floatline and float are detached, the end of the mainline is recovered, and the mainline is hauled as described opposite.

Alternatively, the lines can be set adrift so the boat can then motor to the other end of the string and recover them as for drifting lines, as described in the next paragraph.

Recovering drifting lines

If the vertical longlines have been set adrift, either singly or in strings, then they will need to be recovered and the surface lines disconnected before hauling can begin. For single drifting lines, the gear can be picked up in the order it was set so that each line has a roughly equal soak-time. For strings of drifting lines, the gear can be recovered from either end, but again it is preferable to start from the line that was set first to equalise the soak-time.

The main consideration when recovering drifting strings is that the boat should always approach the string from a downwind direction so that the wind will not push the boat over the lines as the crew are trying to get organised for hauling.

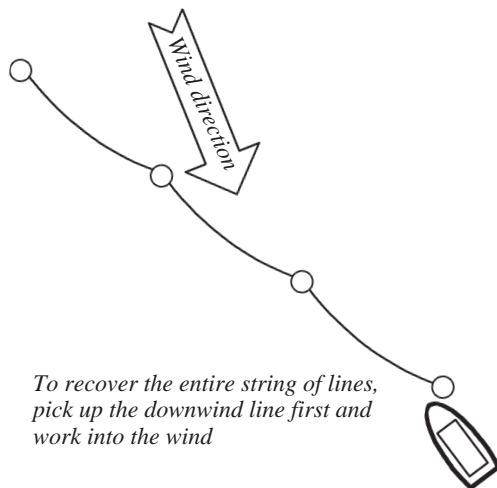

Alternatively, if it can be seen that there is a fish on one of the lines, this line can be hauled and re-set individually without disconnecting the floatlines from each other and without disturbing the other mainlines.

Once the primary float of the selected line has been retrieved, the boat is allowed to drift away from the other lines. Hauling is then conducted as described on the opposite page.

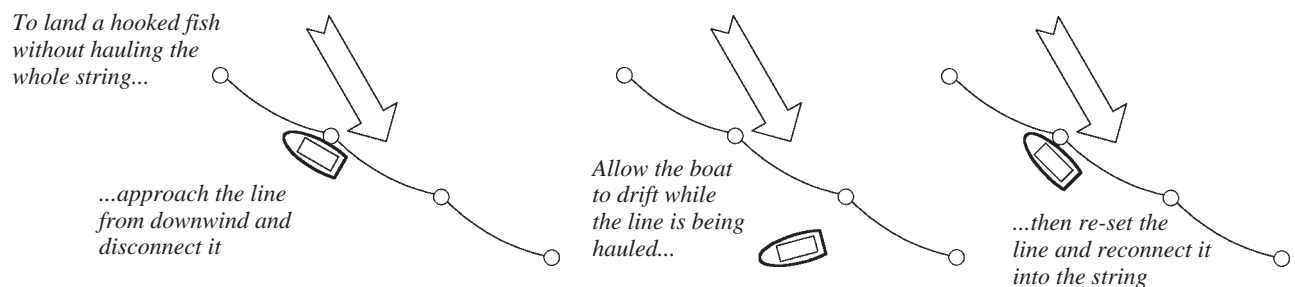

RE-USING BAITED BRANCHLINES

Sometimes a vertical longline will catch a fish soon after setting and have to be hauled again quite quickly. In such a case the branchlines can be put aside with their bait still intact so that they can be re-used once the fish has been boated and the line is re-set. In this case the baited hooks should be arranged systematically on a board or along the edge of the boat so that they will not become tangled, and where they will not be left in the sun for any length of time. The principle of 'first in, last out', as used in a normal branchline bin (see section 2D) should be used here too, so that there is no chance that the branchline on the bottom of the stack will be picked up first and become tangled with the others.

Baited hooks that will be re-used can be stored temporarily on a board or rail

Provided they are organised 'first-in last-out', the branchlines will not tangle

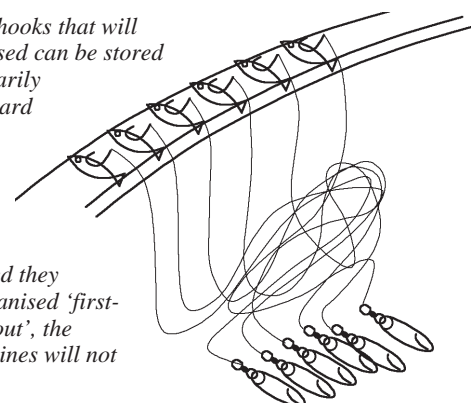

SECTION 2I: TARGETING FISH CONCENTRATIONS

If the catches from vertical longline fishing are to be maximised, it is important to make sure the gear is operating in the areas where the target fish are concentrated. If fishing is being carried out in the open ocean, the location of fish concentrations may not be known, and may need to be located through trial and error. However if the fishing is taking place around FADs, over seamounts or in ‘tuna holes’ (places of known tuna abundance) then it can be reasonably supposed that fish will be concentrated in those areas. The fisherman needs to ensure his lines are set close to the fish concentrations in order to increase his chances of catching them.

FISHING TIED TO THE FAD

When fishing around a FAD, the easiest way to ensure the lines are close to the FAD is to tie the boat to the FAD and fish from that position. Once the boat is tied off to the FAD the first mainline can be set using the sinker-first technique (sections 2E and 2F) and then streamed off to the stern or buoyed off and allowed to drift free so that another line can be set. Alternatively the lines can be set to form a string which remains attached to the FAD, with the boat tied off at the end.

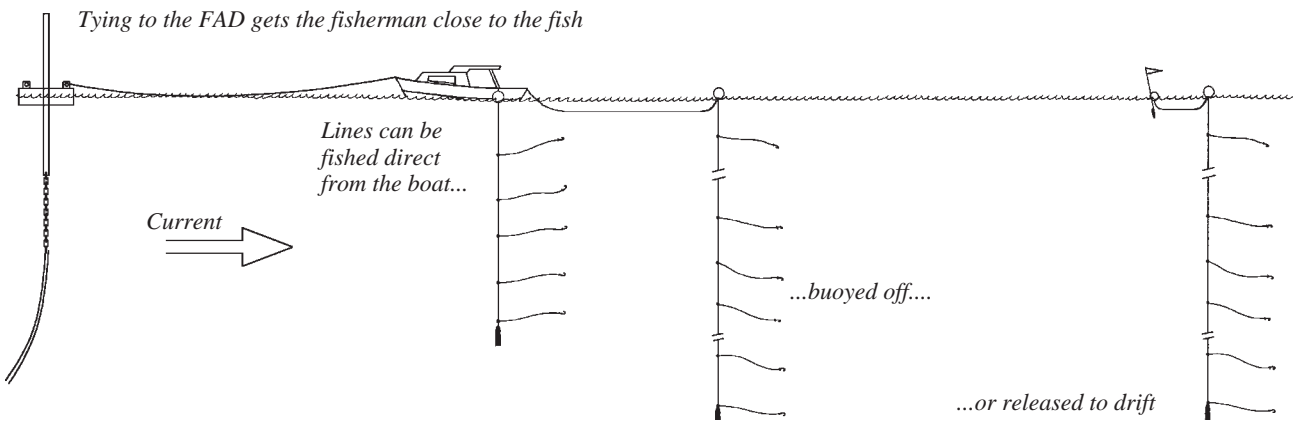

Another technique is to set the lines in a string and leave this tied to the FAD while the boat goes to do something else (trolling, for instance). These various options ensure that all the lines set are exposed to the concentrations of fish that may be around the FAD.

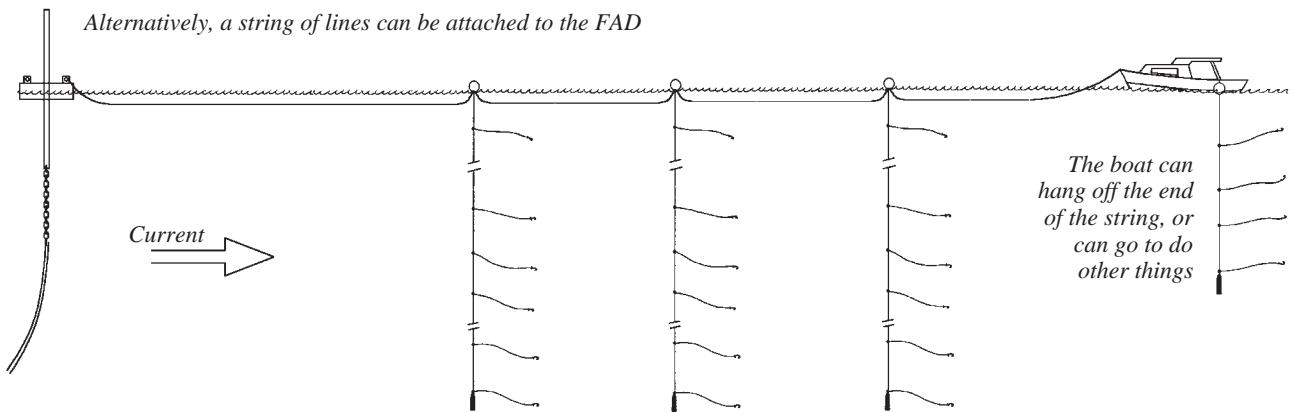

There are nevertheless a number of problems with fishing while tied up to the FAD. For one thing, fisheries authorities in many places discourage or prohibit fishermen from doing this (because of the risk of large boats dragging or damaging the FAD mooring) in which case the rules should be respected. Another problem is that if there are several boats wanting to tie up to the FAD, conflict may arise about who gets to do so. If a number of boats tie up end-to-end, as is the practice in some locations, then all but one of the boats is restricted to fishing only one line, since only the boat at the end of the queue will be able to drift lines off the stern. Finally, if there are troll fishermen operating in the area, they will want to make passes close to the FAD and may finish by hooking up on the vertical longline gear, causing problems for both sides. Therefore, while tying up to the FAD is a good idea in theory, it may be hard to get away with in practice.

DRIFTING LINES THROUGH FISH CONCENTRATIONS

Another way to ensure that the fishing gear passes through the area where fish are supposed to be concentrated is to set it up-current so that it can drift through the area in question. This technique is useful whether the fish concentration is around a FAD, over a seamount, in a tuna hole, or wherever. Fish are often found in the area up-current of a FAD or seamount, and drift-fishing allows the fisherman to fish these areas.

Drifting lines past the FAD

To have the line drift correctly it is first necessary to know which way the current is running. With a FAD this can usually be determined quite easily by approaching closely to the FAD and looking which way the mooring, appendages or strings of algae under the FAD are lying.

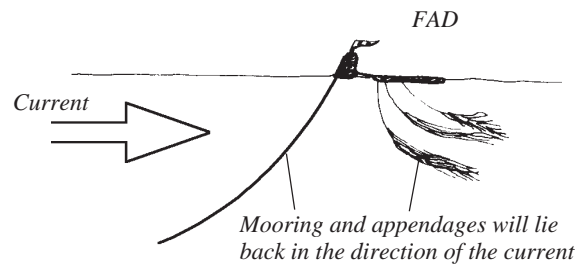

A flag buoy tied to the FAD will hang down-current...

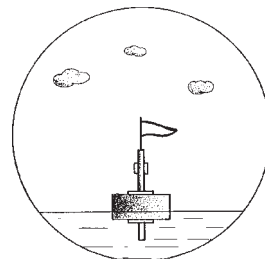
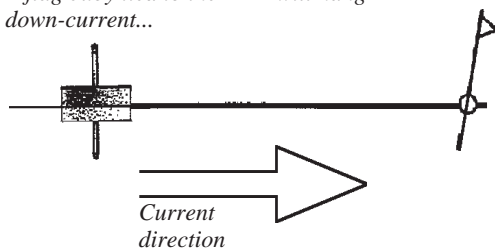

...so the up-current position can be determined by lining up the buoy behind the FAD

If there is nothing to give an obvious clue, an alternative is to attach a length of floatline and a flag buoy or easily visible small float to the FAD. The buoy will orient itself with the current and will be visible from a distance, so the boat can position itself up-current of the FAD by simply lining up the buoy and the FAD.

Once the current direction has been determined, lines can be set to drift using either the sinker-first or the float-first method. Care should be taken to set the vertical longlines off to one side of the alignment between the FAD and the flag buoy so that they will drift past the FAD and not straight into it, causing a tangle. The direction of sub-surface currents may not be the same as those in the surface layers, and hooked fish may drag the vertical longline away from its expected path of drift. In addition, FADs are usually set with 20-25 per cent of scope, so in calm weather the FAD mooring line may be floating close to the surface even at a distance from the raft itself. A margin of error of at least 200–300 m should therefore be allowed.

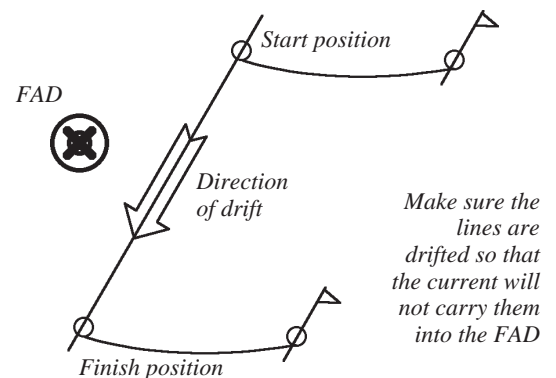

Drifting lines in open water

In the case of seamounts and tuna holes, assessing the direction of the current is more difficult, but it is also less critical since there are no obstacles for the line to drift into. The best method is to make a preliminary assessment of the current by throwing a piece of bait (or some other neutrally buoyant material) into the water and watching which way it drifts. Once a rough assessment of the current direction has been made, the first longline is set and allowed to drift. This is then observed for a few minutes to get a better assessment of current direction before setting further lines.

Drifting lines in strings

As mentioned in section 2G, vertical longlines can be set to drift individually, or they can be set in strings. Setting in strings keeps the lines closer together, helping to concentrate the fishing effort in a narrow area, and makes them easier to locate for retrieval. However it also significantly increases the potential for tangles. In general, longline strings are suitable for use in calm weather, when fishing tied to the FAD or in the area down-current of it. They are also suitable for use over seamounts and in tuna holes where there are no obstacles for them to tangle on. However longline strings should not be set to drift past the FAD from the up-current side, and should not be used when the weather is rough.

SECTION 2J: FISHING WITH A SEA ANCHOR

When setting vertical longlines to drift, their distance from the boat quickly increases and they can soon be lost from view, especially if the crew are busy setting more lines. Searching for the lines in order to retrieve them can be very time-consuming and motoring the boat over long distances during the search can waste a lot of fuel.

In fact the usual reason that the lines and the boat become separated is not because of the lines drifting away from the boat, but because the boat is pushed away from the lines by the wind. While the lines, which are almost entirely submerged apart from the tops of the floats, are affected mostly by the current, the boat is affected by both, and usually the wind is more important. A displacement hull with plenty of volume below the water line will offer a certain amount of resistance to wind movement, but a light, shallow-draft boat such as an ‘alia’ catamaran will quickly be blown long distances if there is much wind.

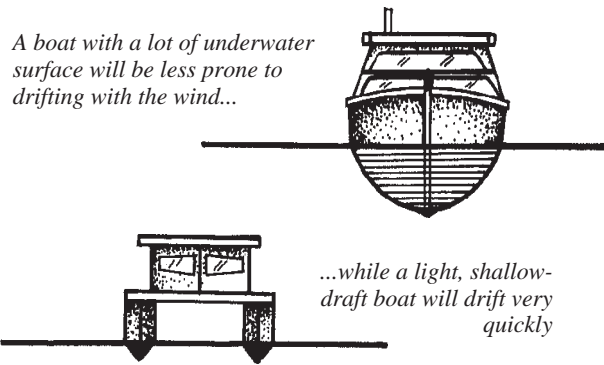

A sea anchor, as described in section 1J, is the solution to most of these problems. The sea anchor provides a huge underwater area which gives the boat a great deal of resistance to movement by the wind, and instead makes it move in the direction of the current. Using a sea anchor thus slows the boat down so that more lines can be set in a narrow area, such as around a FAD. Once the lines have been set to drift the boat will remain close to them, making it easier to spot any strikes and quicker to recover the line. Even in light winds the use of a sea anchor is a valuable tactic in vertical longlining.

FISHING WHILE USING A SEA ANCHOR

The method of operating a vertical longline when using a sea anchor is similar to fishing while tied to the FAD (see section 2I). The first longline is set sinker-first and then either streamed out from the boat or allowed to drift free in order to make room for the second longline, as described earlier. The main difference is that, because the boat is moving in a path that more closely resembles that of the longline, the line will not drift away from the boat so quickly. In most cases the line will move ahead of the boat instead of drifting astern, with a chance of it tangling with the sea anchor.

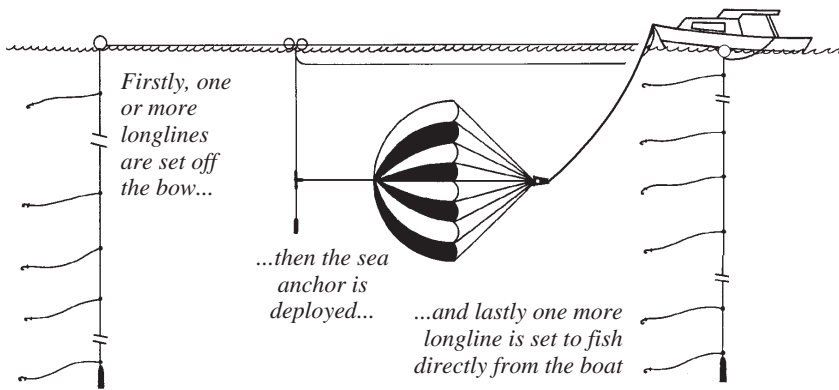

Vertical longlining using a sea anchor

Because of these considerations many fishermen prefer to get the lines set and in position first, either streamed out from the boat, or drifting free. Only then do they deploy the sea anchor, manoeuvring the lines as required as the boat settles in to its new position. The final result is usually that, if a string of vertical longlines has been streamed out from the boat, they will end up drifting ahead of the boat, with the sea anchor in between.

Once the whole system has stabilised it will drift together and an additional mainline can be set to fish close to the boat.

HAULING THE LINES

When a fish is caught on one of the longlines set forward of the bow, the longline at the side of the boat can be released to free-float with the current. The sea anchor is then hauled aboard the boat and the floatline connecting the vertical longlines to the boat is released from the bow. The line can then be approached and recovered in the usual way, as described in section 2H.

SECTION 2K: GEAR CARE AND MAINTENANCE

No matter what fishing method is being carried out, fishing gear becomes worn and damaged during use, and needs to be regularly maintained and repaired. If this is not done the gear will be weakened and will eventually fail at the moment of greatest stress—when there is a large fish on the line.

NYLON MONOFILAMENT

Monofilament nylon is very prone to wear and nicking which weakens the line and causes breakage. The branchlines and any mainlines made of nylon monofilament should be checked regularly for rough patches which signal abrasion, and tiny cuts. When sharks have been caught on the line, check the section of mainline close to the branchlines on which sharks have been taken to see whether their rough skin has caused any damage.

Knots or crimps require special attention. As well as being weak points already, knots are also the places where the greatest amount of abrasion occurs through normal wear and tear. Check to make sure that the ‘knuckles’ of knots are not showing signs of excessive wear. Crimps may cause nicking of the line at their edges, and may themselves start to lose their grip if they develop any oxidation or hairline cracking. Cut out any suspect knots or crimps and rejoin the line.

ROPES

Rope materials are not so prone to wear and tear as nylon monofilament, but should still be checked from time to time. Keep an eye out for abraded knots, and for any splices that look like they might be starting to slip or wear.

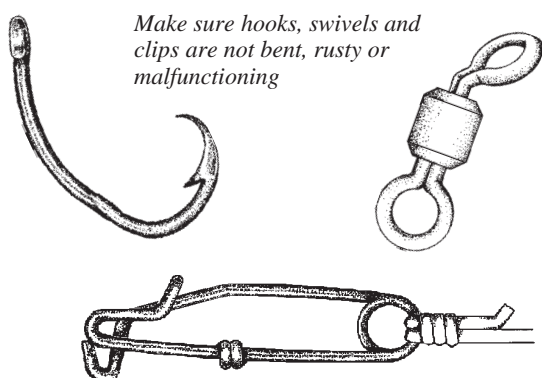

Line wear and tear

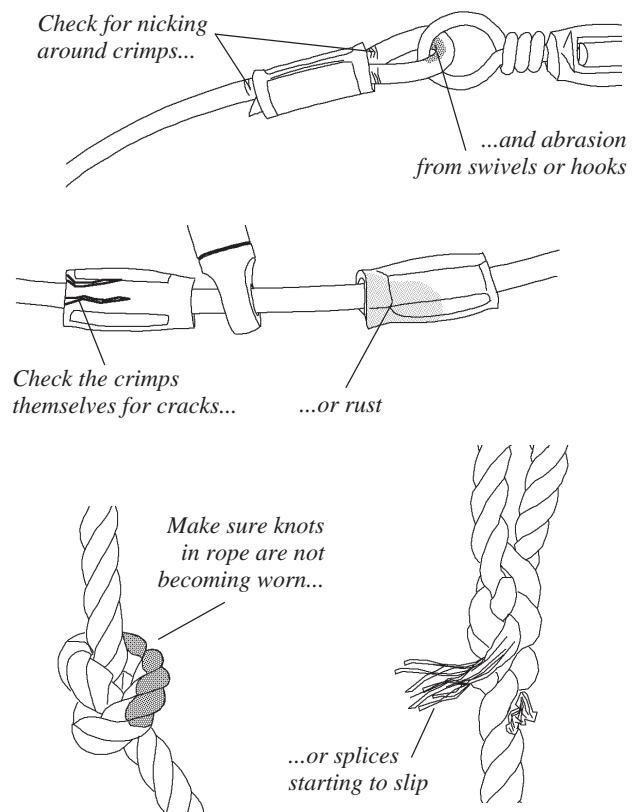

HOOKS, SWIVELS AND CLIPS

Hooks which have been in use for a while are prone to become blunt and rusty from wear. They can sometimes be sharpened with a file or stone but this then removes the galvanised coating from the hook and increases the rate of rusting. Once the hooks become too rusty they should be replaced. Continued use of rusty hooks to save money is a false economy as they will result in fewer hook-ups and a lower catch. The same goes for hooks which have been bent by a large fish. These should be discarded and replaced, not bent back into shape, as this will weaken them and they may break or straighten when taken by the next big fish.

Swivels should be checked regularly to see that they have not become rusty or bent and that they are still turning properly. Longline clips should be checked to see that they are not bent and that they still close properly. Any suspect item should be replaced before it gets a chance to fail at an important moment.

Maintenance inspections should be a regular part of the fishing operation. The time when the gear is most visible is when it is being used, so the fisherman and his crew should get into the habit of keeping their eyes open for gear damage or wear during the fishing operation. Any damage that cannot be fixed on the spot should be noted down so that repairs can be carried out after the fishing trip is over.

SECTION 2L: SCALING UP THE FISHING OPERATION

HANDLING MORE LINES

If a fisherman finds that fishing vertical longlines is productive and he wants to set more gear, he will be faced with the problem of managing hundreds of metres of mainline during a single fishing trip. The best way to handle and control all this line for easy use is to build a larger-scale longline drum which can be used for setting, hauling and storage of the mainlines.

A LONGLINE DRUM DEVELOPED BY SPC

Description

An example of a suitable drum, developed by SPC Masterfishermen over a long period of fishing trials, is shown below. The wooden hauling drum resembles a scaled-down version of the mechanised reels used by industrial monofilament longline fishermen. It can carry ten 300 m mainlines and is used both to set and haul the gear. The reel can be made using simple hand tools and is easy to build from materials that are locally available throughout the Pacific Islands.

A longline drum developed by SPC

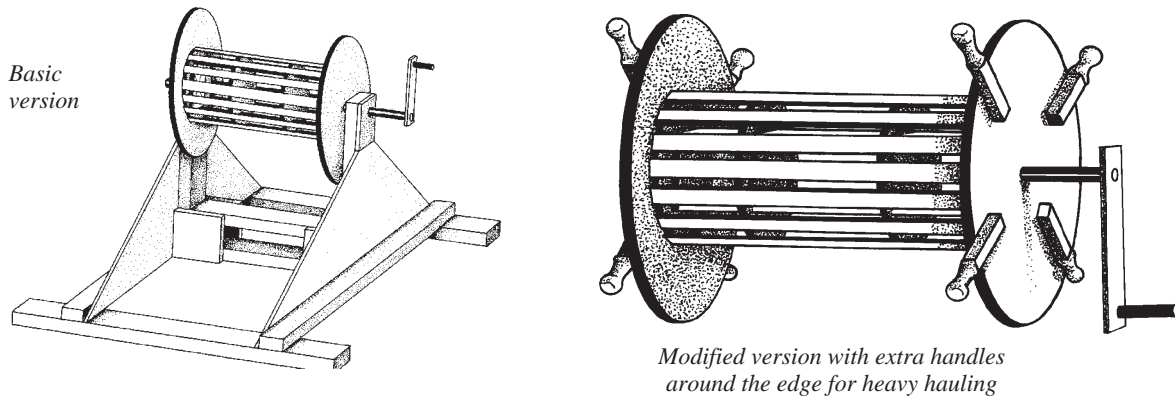

Specifications

Many variations on this basic design have been built by fishermen according to their own particular needs and preferences. Details of the longline drum developed by SPC, including specifications, a full materials list and instructions for building, are contained in the SPC Capture Section Unpublished Report No. 22, entitled *Report on small-scale tuna fisheries development in Western Samoa, 27 September 1990–27 July 1991*, by Peter Watt, Lindsay Chapman and Peter Cusack. This report can be obtained by writing to SPC at the address on the last page of the present manual.

Schematic diagram of a longline drum developed by SPC

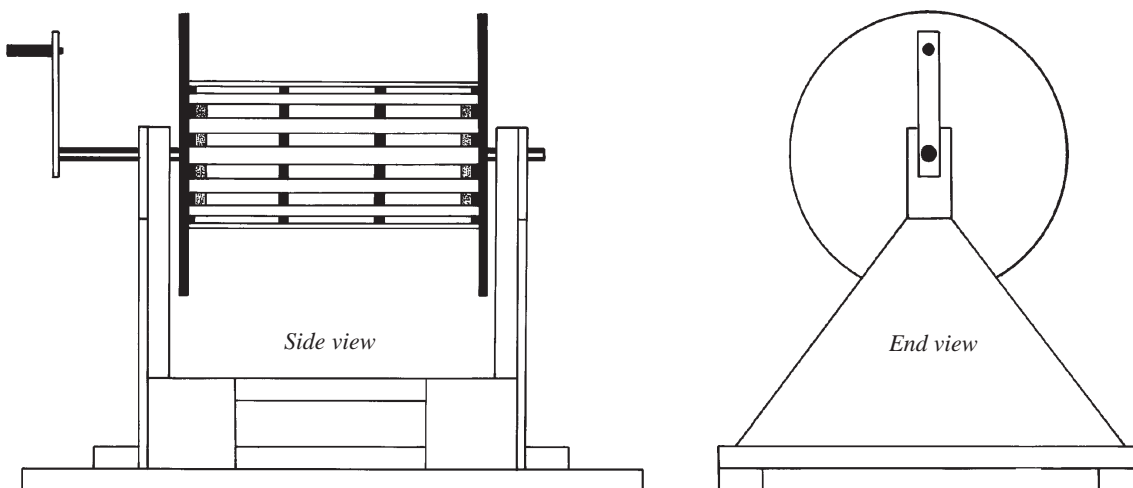

Operating the drum

The procedure for setting and hauling of the gear using the drum is very similar to the methods already described. The drum is secured in a convenient place on the deck and a 15 cm block or pulley, the same as the one described in section 2F, is rigged above the transom of the boat so the line can be set and hauled over the stern, as shown below.

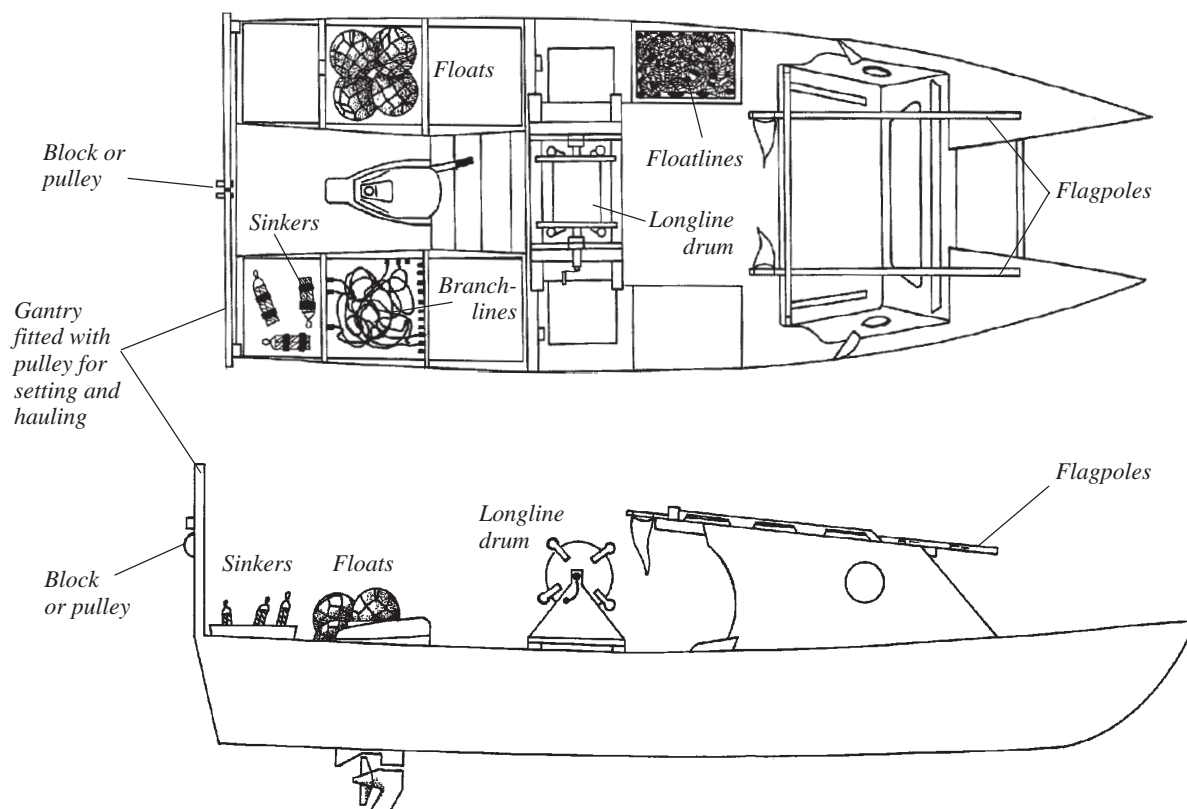

A possible deck arrangement for fishing with a longline drum from an 'alia' catamaran

Once this is done, vertical longlines can be set sinker-first or float-first, as individual lines or in strings, following the principles already described in sections 2E–2G.

SCALING UP FURTHER: HORIZONTAL LONGLINING

The construction of a longline drum takes the fisherman one step further in his progress towards larger-scale fishing operations. Once the drum is constructed and experience gained in its use he can, if he so desires, move up to horizontal longlining. This method involves setting lines which may be several kilometres long using a nylon monofilament mainline. Setting horizontal longlines is perfectly feasible using a hand-operated drum as shown above, and is the basis of an important commercial fishery in at least one Pacific Island country.

Horizontal longlining

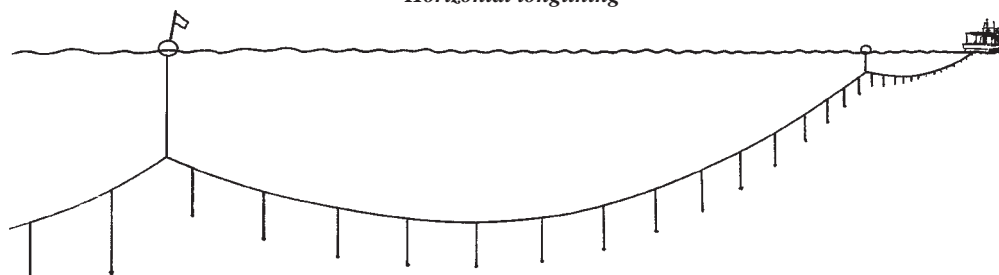

Horizontal longlining is not a fishing method used in association with FADs, and will be treated in more detail in another SPC fishing manual which is expected to be published in 1999.

CHAPTER 3

OTHER FAD-FISHING METHODS

- A. MID-WATER TUNA LINES
- B. THE DROP-STONE METHOD
- C. THE 'PALU-AHI' METHOD
- D. THE 'IKA-SHIBI' TECHNIQUE
- E. TROLLING AROUND FADs
- F. CATCHING BAIT AROUND FADs
- G. OTHER POSSIBLE FAD BAIT-FISHING METHODS
- H. NON-FAD BAIT-FISHING METHODS

INTRODUCTION

This chapter describes a number of other fishing methods that have some relevance to FADs. The first few sections deal with mid-water tuna fishing techniques that are already practised in many areas, but which should be even more productive if carried out around FADs. Information on trolling around FADs, both as a primary fishing method and as a means of catching bait, is also summarised. The question of catching bait is taken further in the last sections, which describe methods to capture bait fish and squid around FADs and in open water.

SECTION 3A: MID-WATER TUNA LINES

In terms of the gear required, mid-water line fishing is probably the simplest method of catching tunas and other oceanic fish. Nevertheless, considerable skill is required in the fishing operation itself. There are many variations on the basic technique, some of which are described here and in the next few sections. Although traditionally practised in the open sea, these fishing methods are often even more productive when carried out around FADs.

GEAR

The basic gear consists of a long (30–250 m) mainline with a 5–10 m trace attached to the end using a strong swivel (see section 2B). The trace carries a baited hook and, if needed, a sinker. The best hooks are size 13/0–16/0 Mustad tuna circle hooks or similar (see section 2C). Most fishermen use just one hook on the end of the line, but it is possible to use two, as shown in the diagram below.

The mainline may be made from any of a number of materials. Monofilament nylon with a breaking strain of 50–150 kg is the most common, but others include braided lines such as ‘Super toto’, Dacron cord, or Kuralon longline rope. The choice of material will be influenced by the kind of fishing boat being used: canoes and other smaller boats can get away with using much lighter lines, for reasons explained below. Many fishermen like to put knots at regular intervals along the mainline so they can keep a check on the length of line that has been paid out. The trace is normally made of monofilament nylon with a lower breaking strain than that of the mainline, so that if a break occurs only the trace is lost, and not the entire gear. It may be necessary to replace the monofilament trace with wire if there are sharks in the area and the fisherman wants to retain them.

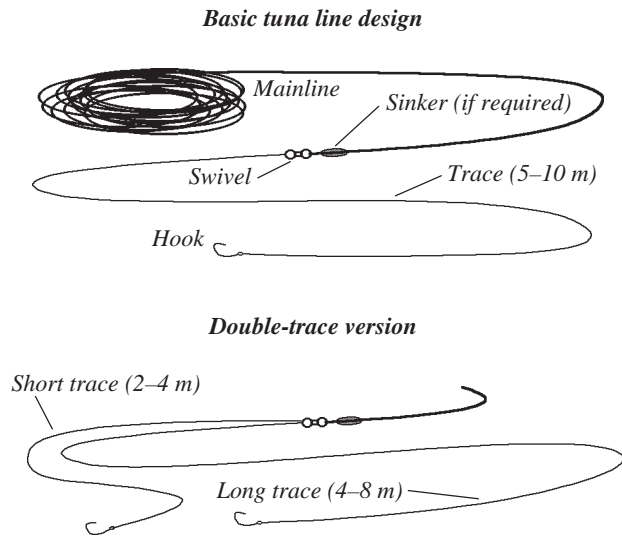

The line would normally be weighted with a sinker heavy enough to carry the bait down to the desired depth under the prevailing wind, current and fishing conditions. In a strong current a sinker of 1 kg or more may be needed, while in a light current a relatively small sinker of 100–200 g could be used. If drifting in a light current it may be possible to fish with no sinker at all, especially if a leaded swivel is used in the line.

FISHING FROM A CANOE

Normally this type of fishing is carried out from a canoe or other small boat. If the wind or current is causing the boat to drift quickly, it may be necessary to keep station using paddles or the motor in order to prevent the line from streaming behind the boat and being brought to the surface.

Effects of current

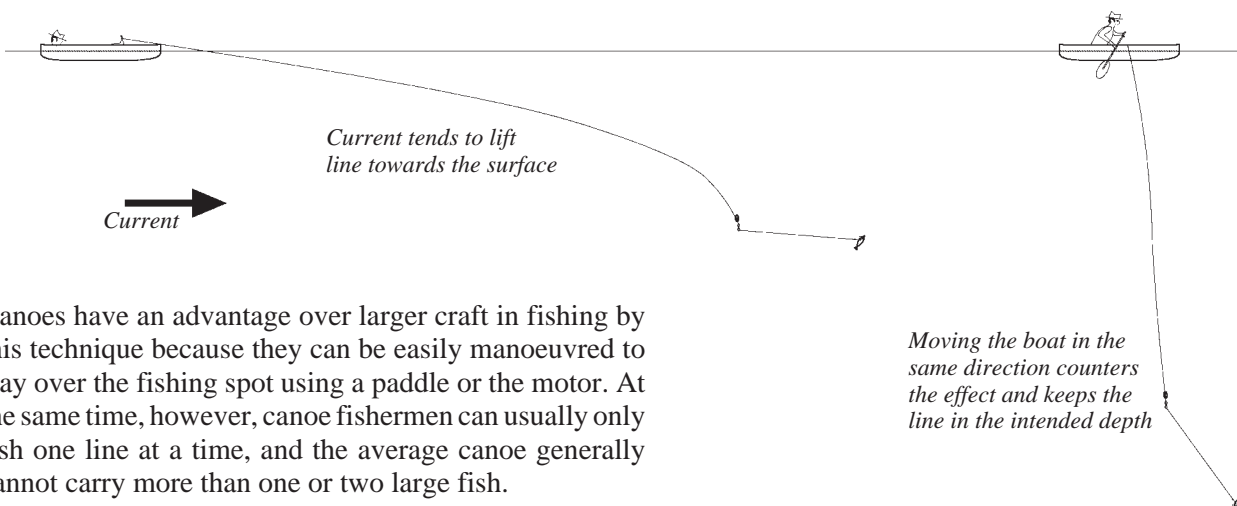

Canoes have an advantage over larger craft in fishing by this technique because they can be easily manoeuvred to stay over the fishing spot using a paddle or the motor. At the same time, however, canoe fishermen can usually only fish one line at a time, and the average canoe generally cannot carry more than one or two large fish.

FISHING FROM A LARGER BOAT

Because of the limitations of fishing from a canoe, many fishermen use the technique from a larger vessel, but this introduces new disadvantages. A canoe is a much more forgiving fishing platform because a large fish fighting on the line will tend to tow the canoe around and tire itself out in the process. A large boat with more resistance is more likely to allow the fish to break off. This means that the fisherman has to be a lot more careful about playing the fish, allowing it some line when it makes a strong run.

The advantage of fishing from a smaller vessel

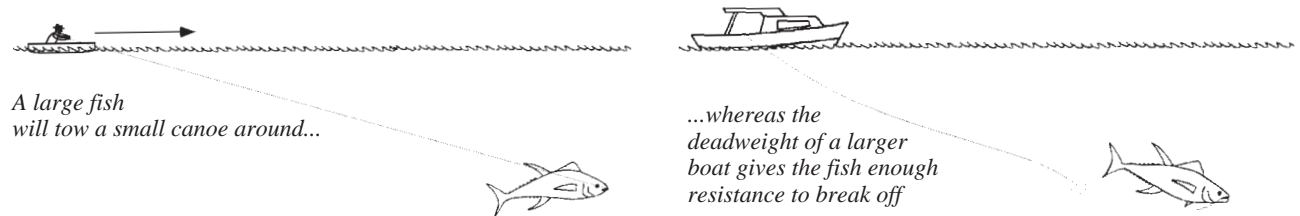

Small polyform buoy supports the line and provides resistance to hook and tire the fish

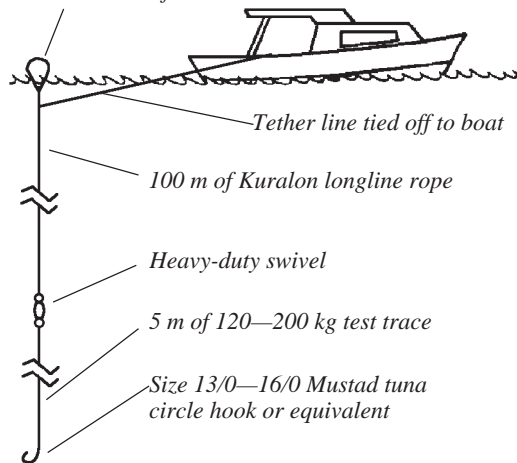

BUOYING OFF THE LINES

To reduce the likelihood of break-offs, many fishermen attach a buoy to the upper end of the line. As well as providing some resistance against which the fish can tire itself, the buoy also helps set the hook when the fish makes its strike.

This kind of fishing can also be carried out by attaching the lines to a buoy and allowing them to drift. By doing this a single vessel can fish up to 10 lines at a time. Being free of the boat the lines drift with the current so the hook will tend to stay deep instead of being pulled up towards the surface. As a result, sinkers may not be necessary when lines are allowed to drift free.

TARGETING SHARKS

The gear may also be used to target sharks, which are often a nuisance around FADs, attacking hooked fish and damaging gear. When targeting sharks the line needs to be modified by using a large straight hook rather than a tuna circle or BKN hook. In addition, the nylon trace should be replaced by a 4–5 m long trace made of multi-strand wire which will resist cutting by the shark's teeth and abrasion by its skin if the line rubs against its body. 7-strand or 49-strand stainless steel wire, or 9-strand Turimoto galvanised longline wire, both of about 200 kg breaking strain, are good trace materials. As always, the trace should be attached to the mainline by a swivel to avoid tangling.

Simple floating line for mahimahi

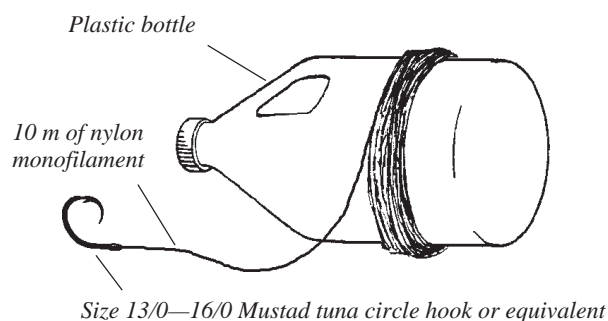

TARGETING MAHI MAHI

A variation of the gear is used to target mahi mahi or dolphin fish. About 6–10 m of 1.5–2.0 mm dia. nylon monofilament fitted with a tuna circle or similar hook is attached to and coiled around an empty 2-litre plastic bottle. The hook is baited and the whole rig then thrown in the water and left to drift, where the line slowly unwinds. Any fish caught tire themselves out fighting the flotation of the bottle, and eventually return to the surface. The gear is then retrieved after 30 minutes or so. Because they fish unattended, a fisherman can operate several of these lines at once.

SECTION 3B: THE DROP-STONE METHOD

A specialised variation on the mid-water line fishing method, called drop-stone fishing, has been used traditionally in many Pacific Islands, especially those of Polynesia. This method uses a long, flattish stone weighing 1–2 kg, around which the trace is wrapped several times and tied with a quick-release knot. It allows the fisherman to get the baited hook down to the required depth and then to release the stone, so that the hook hangs free in a natural-looking manner. The technique also makes use of chum, or finely chopped bait, which is dispersed in the water around the hook to attract the tuna. The chum is usually made from chopped-up bits of the same bait that is being used on the hook, although some fishermen supplement it with coconut meat.

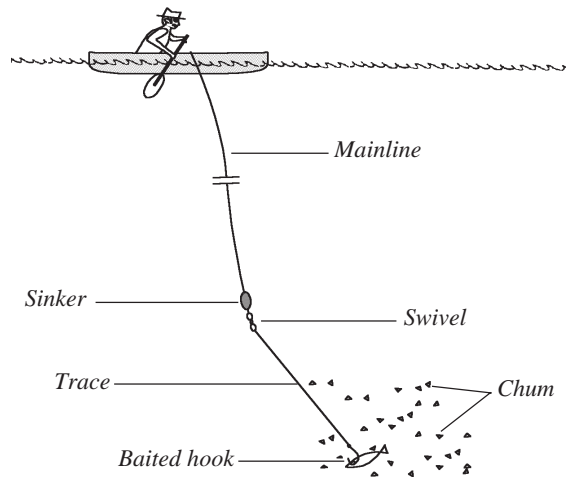

GEAR

The gear used is an ordinary tuna handline, as described in section 3A. To maintain the natural look of the bait, a sinker is not usually attached to the mainline, although this may be necessary if there is a strong current forcing the bait to the surface as shown in section 3A.

To carry out this fishing method, the fisherman needs to carry a supply of stones of the correct size and shape. Rounded volcanic pebbles with one flat side, about twice as long as they are wide, are the best. On atolls or in other areas where there are no stones, small giant-clam shells about 15 cm long are used instead.

Preparing the bait parcel

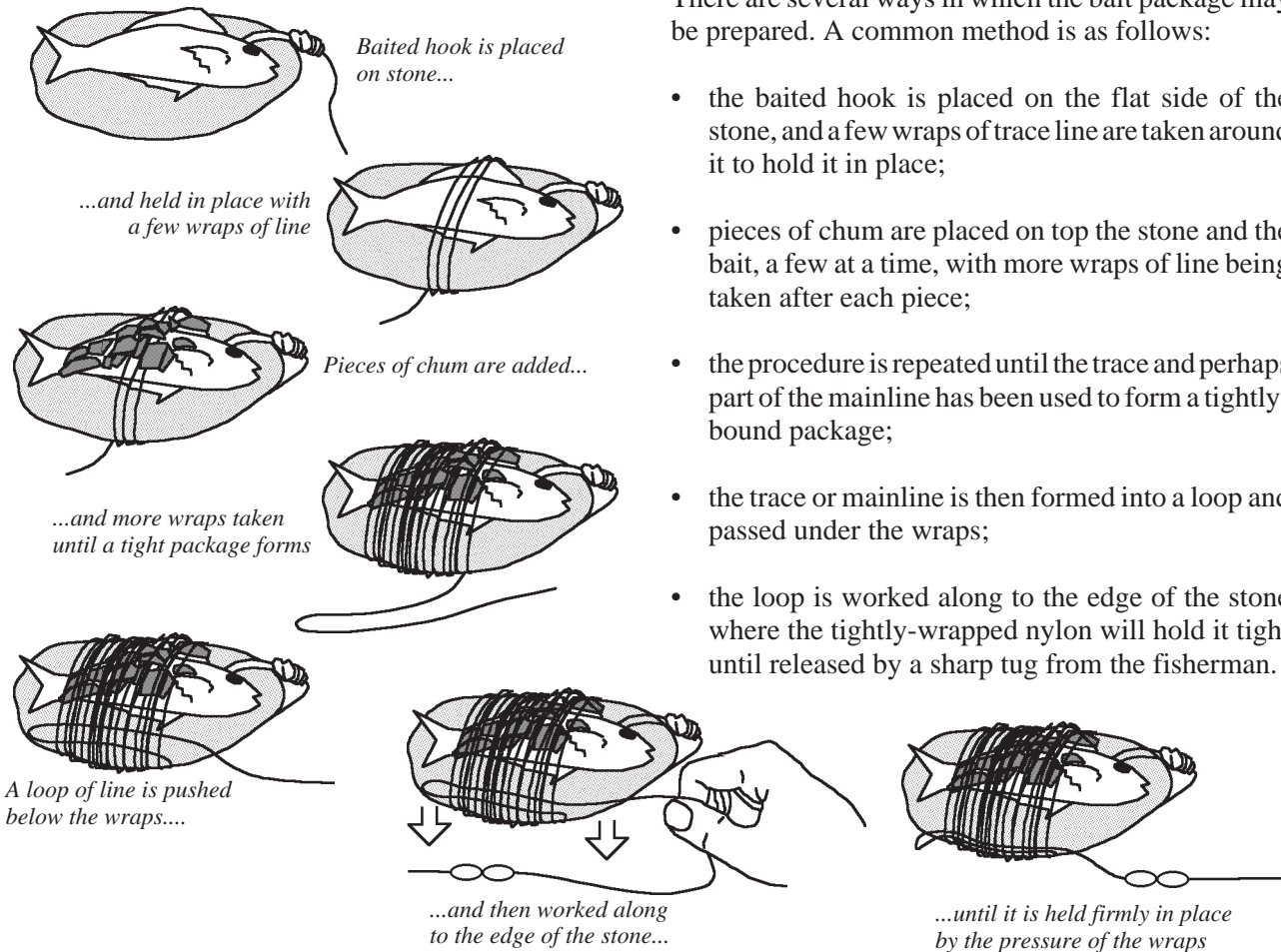

PREPARING THE BAIT

There are several ways in which the bait package may be prepared. A common method is as follows:

- the baited hook is placed on the flat side of the stone, and a few wraps of trace line are taken around it to hold it in place;
- pieces of chum are placed on top the stone and the bait, a few at a time, with more wraps of line being taken after each piece;
- the procedure is repeated until the trace and perhaps part of the mainline has been used to form a tightly-bound package;
- the trace or mainline is then formed into a loop and passed under the wraps;
- the loop is worked along to the edge of the stone where the tightly-wrapped nylon will hold it tight until released by a sharp tug from the fisherman.

USING A BREADFRUIT LEAF

In some places the package is wrapped in a breadfruit leaf or other broad leaf, to prevent bait escaping too soon. If this variation is used, the procedure for preparing the gear is a little different than that described above.

- the bait is placed on the stone and several wraps are taken with the trace;
- the stone and bait are placed on a large breadfruit or similar leaf;
- all the chum is placed on top of the baited hook;
- the leaf is folded up around the package and more wraps taken with the trace in order to bind it closed;
- the package is completed by making the same slip knot as described on the previous page.

Using a breadfruit leaf

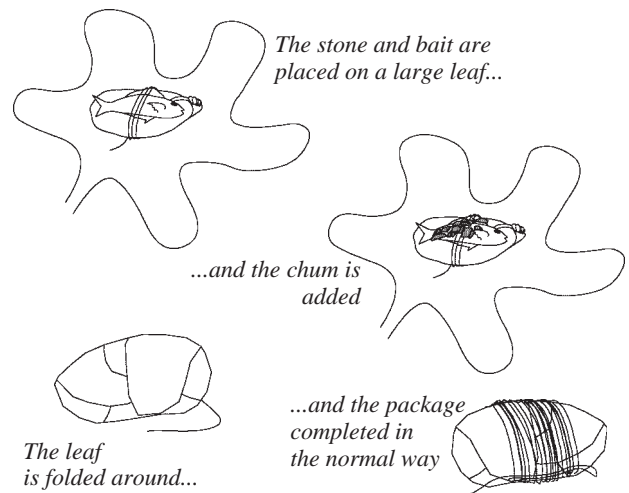

FISHING OPERATION

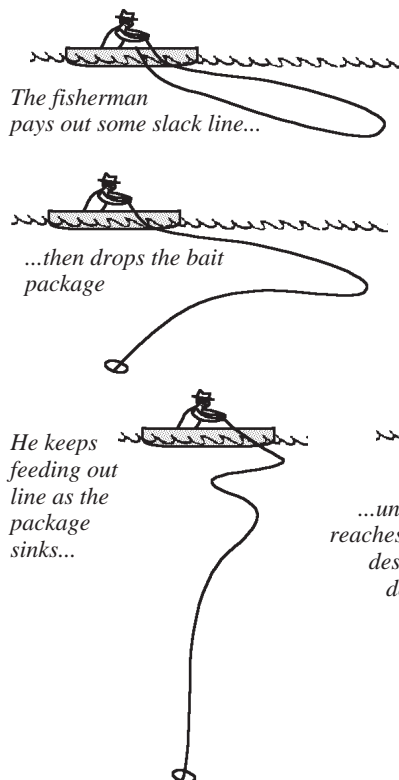

Once the package has been prepared, the line is cleared so that it will run out without obstruction, and the package is then dropped over the side of the boat. Care must be taken to allow the line to pay out at its own rate, and to make sure it is not stopped or allowed to catch on the boat, otherwise the bait package will be jerked open too soon. Most fishermen prefer to pay out several metres of line into the water before they release the package, to make sure it falls freely. By continuing to pay out line quickly as the stone sinks they make sure it does not come apart too soon. They can also measure the fishing depth by counting arm-spans as they feed out the line.

When the bait is at the desired depth the line is gently slowed so that it will come to stop without the package opening. The line is held for a few moments until it has time to straighten out and assume as close as possible to a straight up-and-down position.

The line is then jerked sharply by the fisherman, causing the slip knot to come undone. The weight of the stone causes the line to start unraveling, and this can be felt as the stone sinks. Once the stone (and leaf, if used) is free of the gear, the baited hook is left at the desired depth in a cloud of chum.

The fisherman then maintains station using a paddle or the boat's motor as shown in section 3A. This ensures that the line stays vertical in the water, and the current does not separate the chum and bait too quickly.

SECTION 3C: THE 'PALU-AHI' METHOD

Palu-ahi fishing is a modern Hawaiian adaptation of the traditional drop-stone method described in section 3B.

GEAR

The basic gear is similar to the tuna handlines shown in section 3A. The mainline is normally made of dacron cord or some other braided polyester or nylon material, and has a nylon monofilament trace attached to the end by a swivel. However instead of stones this method uses a flat 1–2 kg lead sinker. Specially-made oval-shaped sinkers can be purchased or made, but a SCUBA diving-belt weight can also be used. And, instead of breadfruit leaves, a square piece of denim, canvas or other heavy cloth is used to wrap the bait package.

Before fishing, the sinker and denim wrapper need to be prepared in the following way. One end of a short length of cord or nylon monofilament offcut is attached to the sinker, and the other to one eye of a swivel. One corner of the denim cloth is tied or stitched onto the cord and the swivel eye so that when the cloth is laid flat the sinker lies in the centre.

The mainline is then passed through the free eye of the swivel, usually before attaching the trace. The swivel, connected to the lead and cloth, will thus be able to run freely up and down the mainline. The fixed swivel which connects the mainline to the trace serves as a stopper, preventing the weight and cloth from sliding close up to the hook.

Once rigged, the mainline is normally coiled and fished by hand out of a box or bucket.

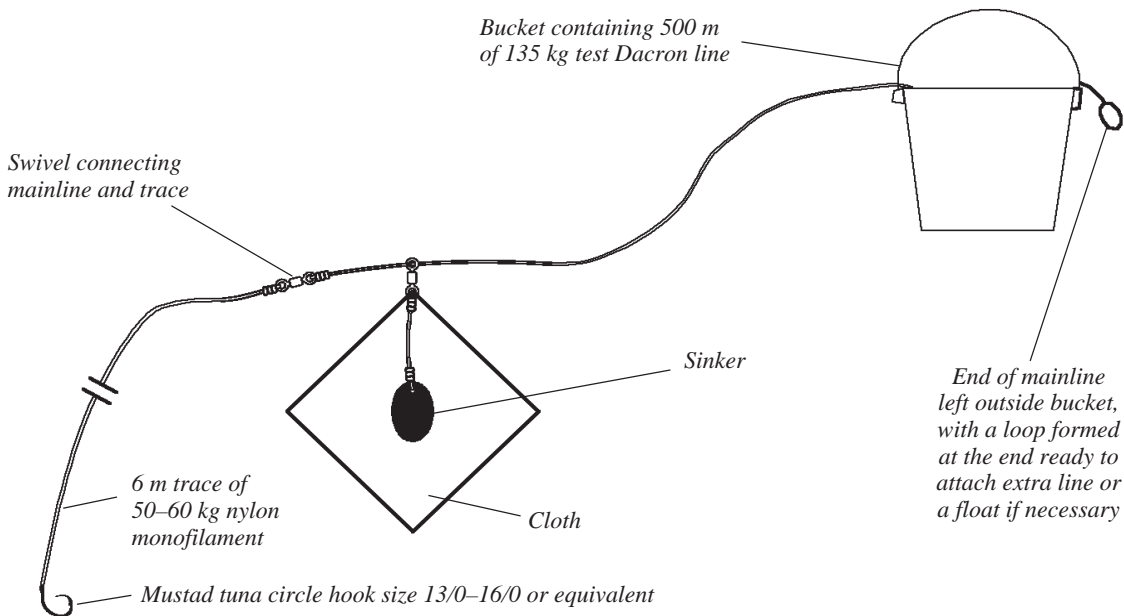
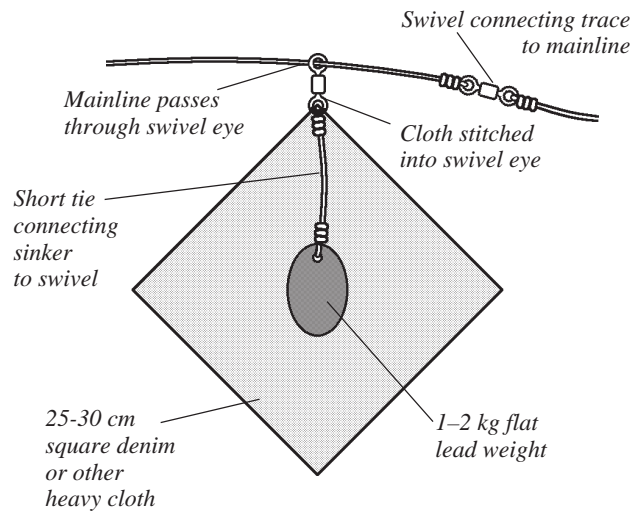

There is a consideration to this form of fishing, which does not apply to the other methods of tuna handlining. Because the heavy lead sinker cannot be removed from the mainline, it can represent a danger to the fisherman and the fishing operation when landing a fish. If a fish has been brought alongside the boat and the sinker retrieved, and the fish then makes another run, any knots or kinks in the mainline may catch in the swivel and cause the sinker to be pulled over the side, possibly doing some damage in the process. Alternatively, if the sinker hooks up, the line could jam and break. Every care should therefore be taken to make sure that there are no kinks, knots or other obstructions that will prevent the mainline running freely through the swivel.

PREPARING THE BAIT PACKAGE

The method of preparing and using the gear is somewhat different to the traditional method described in section 3B:

- the denim is laid out flat;
- the two swivels are pulled up hard against each other so that the lead weight lies in the middle of the cloth;
- the trace is rolled into a coil about 10 cm in diameter and placed on the cloth under the lead weight;
- the baited hook is laid on top of the weight;
- a handful of chum is placed on top of the bait;
- the corners of the cloth are folded up to form a parcel, with the corner attached to the swivel being folded last;
- the mainline is wrapped 5 or 6 times around the package;
- using the thumb to hold the line in place, a loop about 15 cm long is taken in the line;
- another 5 or 6 wraps are taken at right angles to the first ones. The loop already made finishes by sticking out from the wraps;
- a second loop is taken in the mainline. Using this plus the first loop already made in the wraps, a slip knot is tied. The knot is made by passing one loop under the other one 3 or 4 times;
- the slip knot will hold the package together during the drop but will slip easily when the line is tugged.

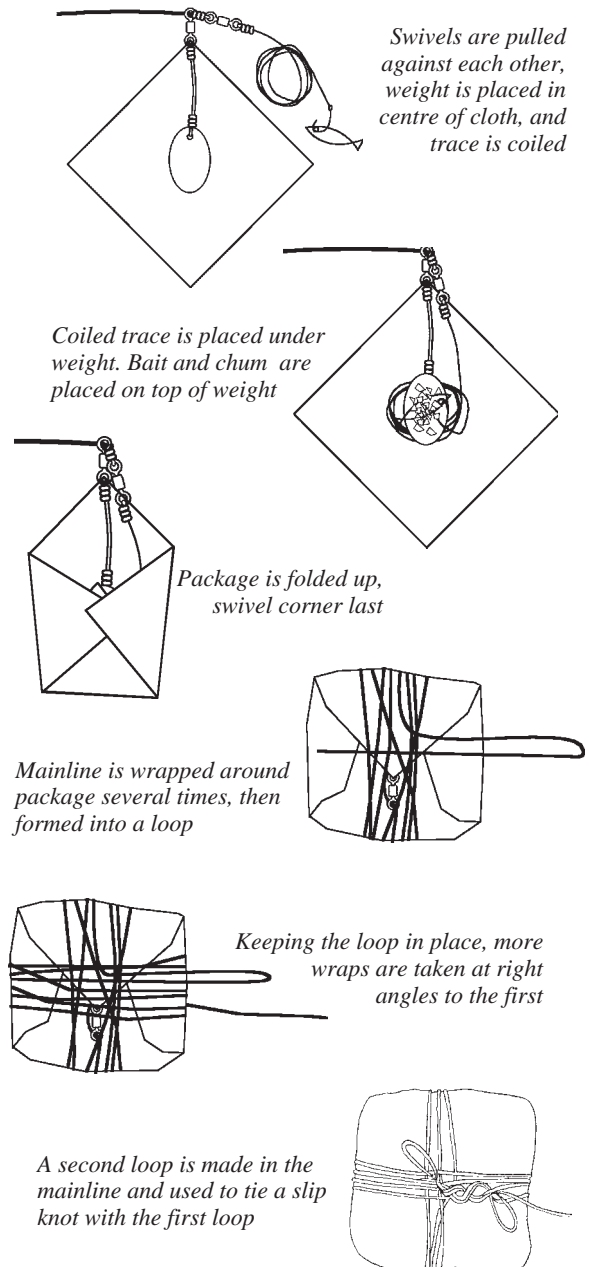

FISHING OPERATION

The palu-ahi fishing operation differs slightly from the traditional style. The bait package is dropped over the side and allowed to run out in the standard manner, as described in section 3B. The depth of the line is judged by counting arm-spans, or by placing knots in the line every 10 m. Once the right depth has been reached and the line stopped and allowed to settle into a vertical position, the package is also released in the normal way by a sharp tug from the fisherman.

Unlike the traditional system, however, releasing the package does not cause the trace to be unravelled and straightened out. Instead, when the package comes undone, the trace will still be hanging in loose coils and slowly unfurling. To accelerate the process and reduce the chance of tangles, the fisherman must pull the line in strongly for a distance of 6–8 metres—a bit more than the length of the trace—in order to straighten out the trace. Once the trace has been straightened, the mainline can be slowly fed out to try to keep the bait among the gently sinking cloud of chum for as long as possible.

Since, unlike the traditional method, the line still has a heavy weight attached, the mainline will tend to hang almost vertically while the trace, which is unweighted, will stream out in the current.

SECTION 3D: THE 'IKA-SHIBI' TECHNIQUE

Ika-shibi fishing is described by Sylvia Rodgers in Jim Rizutto's book *Fishing Hawaii Style, Volume 2*. Most of this section is based on that work.

Ika-shibi is Japanese for 'squid-tuna'. The fishery began in Hawaii in the second decade of the 1900s, when Okinawan immigrants started targeting the tuna that often attacked the squid they were fishing for. Since then the technique has been picked up to a small extent in some other Pacific Islands, but there is potential for the method to spread further, especially where there are FADs. At present, however, the technique is still mostly practised in Hawaii, and the following description relates mainly to the fishery as it is carried out there.

Ika-shibi fishing takes place at night using a vessel with a sea anchor (see section 1J). Traditionally the boat is equipped with squid-fishing equipment, including underwater and above-water lights (see section 3G) so that squid will be attracted to the boat where they can be caught and used immediately as bait. In some areas, including in parts of Hawaii, squid are uncommon and other types of bait, such as mackerel scad (see section 1I) are used. Even under these circumstances, however, the lights are still used as they attract baitfish around the boat and these in turn attract the tuna and other large fish.

Most ika-shibi boats also chum the fish using large quantities of chopped-up bait. A night's ika-shibi fishing will typically require about 25 kg of chum.

Ika-shibi fishing

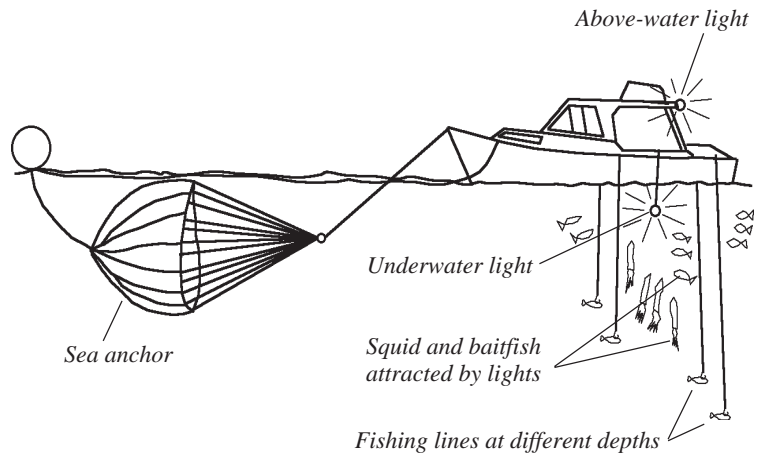

Handline and box

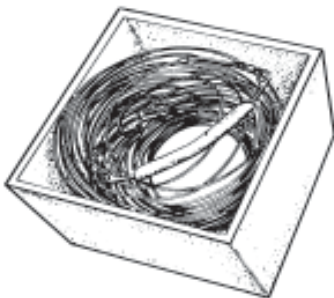

Trace: 0.5–2.0 m of 200 kg test wire or nylon

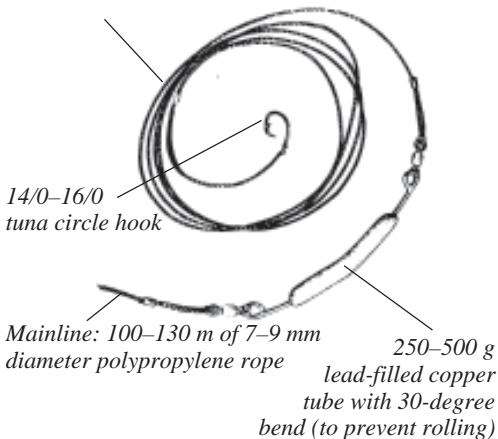

The gear consists of a line, a trace, a lead weight between the two, and a hook. The favourite material for the lines is a 100–130 m length of 7–9 mm diameter polypropylene rope. The trace is either 7-strand stainless (200 kg test) wire, or monofilament nylon of similar strength, sometimes braided for easier gripping. The trace length preferred by most is about 1 m, but traces of 0.5–2 m are used.

The weight is a 250–500 g lead-filled copper tube with a length of stainless steel wire through it, bent in the middle to keep it from rolling around on the boat. The ends are fashioned into eyes and fitted with swivels so that the line and trace can be attached.

The hook is usually a size 14/0–16/0 tuna circle or equivalent (see section 2C). Some fishermen attach a small float to the line to help set the hook and tire the fish. The gear is coiled and kept in a square box for easy handling.

Other equipment used by ika-shibi boats includes: a baseball bat or a wooden mallet, used for stunning the fish; a sea anchor (see section 1J), which is set before fishing commences; and battery-powered 12-volt electric lights which are set both above-water and underwater to attract bait around the boat. The above-water lights are typically 25W incandescent bulbs, while those below water are 25–50W bulbs which have been water-proofed using silicon mastic.

FISHING PROCEDURE

Normally the boat heads out to sea in order to arrive at the fishing grounds at or before dusk. Once there the sea anchor is set and the lights are turned on. As a general rule, three or four well-separated hooks are fished—one or two amidships and one or two at the stern. The lines are set at different depths ranging from 15–35 m in order to spread the fishing effort over the range in which the tuna might be expected. Once the first fish is caught the lines are adjusted to target the depth where the fish seem to be biting.

In the past, fishing for tuna began after 5 or 10 squid had been caught. Today, however, most fishermen bait their lines with mackerel scad so that tuna fishing can start straight away, and then turn to the business of catching squid for bait once the lines are set.

Chumming is carried out continuously while the lines are fishing. Every 10–15 minutes a handful of chum is scattered on the water around the boat. As the night wears on the chum drifts downwards and down-current to form a plume which is intended to attract both tuna and baitfish towards the boat.

To set the tuna line the baited hook is lowered to a depth of 15–35 m. The mainline is then tied to a strong point on the boat with a breakaway line, which stops the line running out any further and thus keeps the hook at the desired depth. The breakaway line is intended to snap when a fish strikes, allowing it to run for a while. However the breakaway line is fairly heavy, about 15–35 kg breaking strength, because it is intended to set the hook when the fish strikes. If a float is being used on the line, this will contribute to the set, and will also prevent the fish from getting enough slack line to allow it to throw the hook.

Breakaway line arrangement

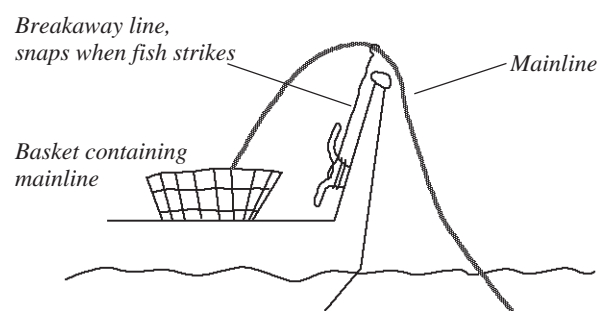

When a tuna strikes, the breakaway line sets the hook and the fish is allowed to run until the outgoing line is slow enough to be handled. The fish is then hauled by hand to the boat.

15–35 kg monofilament nylon breakaway line

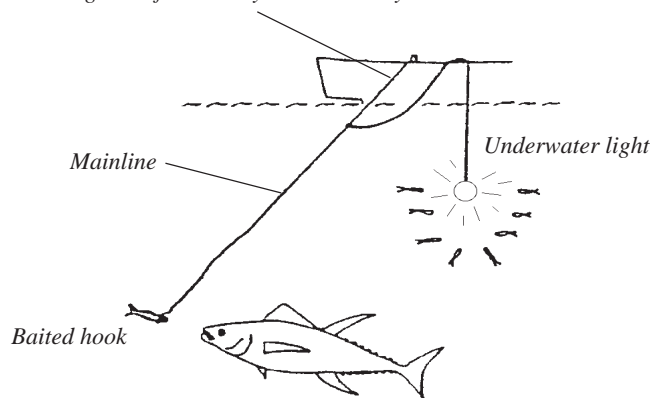

Monofilament line snaps off on strike

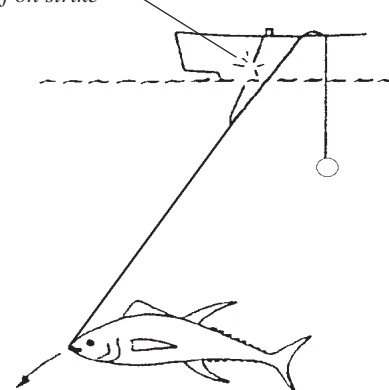

Once the fish is alongside the boat, fishermen differ in their techniques. Some stun the fish and then gaff it, while others stun it after it is on board. Fish are stunned with a blow to the head from the baseball bat or wooden mallet. Recently many fishermen have resorted to killing the fish by shooting it in the head with a handgun when it is alongside the boat. The purpose of this is to make the fish easier to handle and to stop it thrashing around on the boat, which can damage the meat and make the fish less valuable.

When there is a strike, at least one of the other lines is removed from the water as soon as possible to reduce the possibility of the lines tangling. This practice is not followed when the tuna is small enough to land quickly or during times when strikes are infrequent. Tuna strikes tend to be clustered and, while it is possible to keep two lines with struggling fish from tangling, it is almost impossible to do so with three or four lines. The fishermen claim that tuna schools move away when the lines get tangled.

SECTION 3E: TROLLING AROUND FADs

GENERAL

Trolling is probably the most common fishing method practised around FADs. It can be carried out commercially in its own right, but is also a principal source of bait for many other fishing methods. SPC Handbook No. 28, *Trolling Techniques for the Pacific Islands* by Garry Preston, Lindsay Chapman, Paul Mead and Pale Taumaia, gives detailed information on trolling gear and methods. This section briefly summarises some of the information relevant to FADs from that publication.

The fish caught by trolling around FADs are mainly small tunas, which often occur in large surface schools, as well as associated types such as mahimahi and rainbow runner. Oceanic barracudas are often present and many FADs seem to rapidly develop resident populations of sharks which can be a nuisance when trolling. Larger fish are usually (but not always) found at greater depths.

GEAR

FAD fishing incorporates elements of both deep-water or ocean trolling, and trolling surface tuna schools. It is therefore necessary to be prepared for both these types of fishing — that is to have on board both heavy duty lines rigged with large lures or baits, and lighter lines rigged with small plastic octopus or other lures. It will probably be necessary to change between one type of gear and the other during fishing.

FAD trolling gear

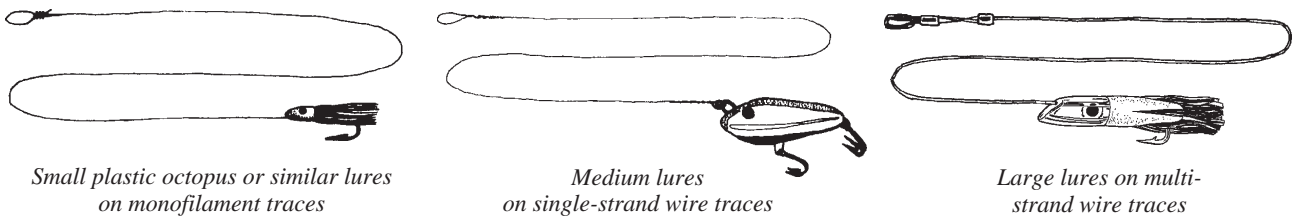

SURFACE AND SUB-SURFACE TROLLING

Trolling around FADs can be roughly divided into two forms:

- **surface trolling** (less than 2m deep), which targets smaller tuna in surface schools but which also takes associated types such as mahimahi and rainbow runner;
- **sub-surface** (2–10 m deep) or **deep** (more than 10 m deep) **trolling**, which targets larger fish at greater depth.

Surface and sub-surface trolling

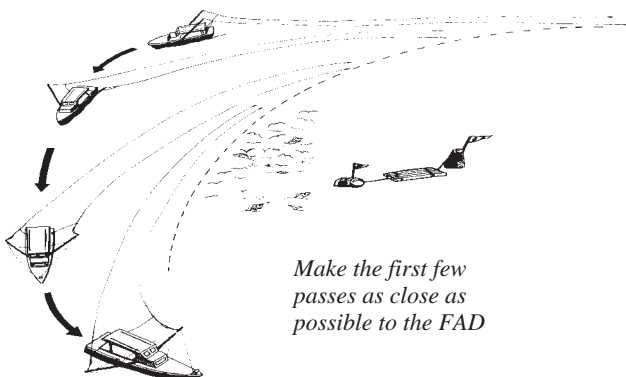
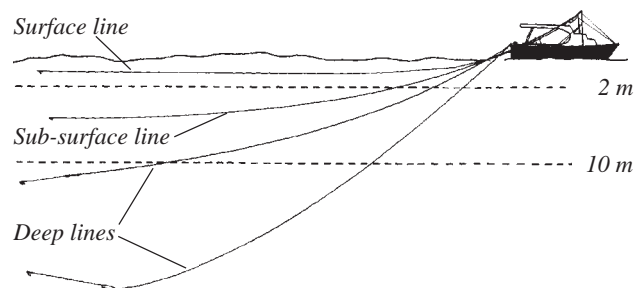

SURFACE TROLLING

When the FAD is first approached, it usually pays to troll fairly slowly, using heavier gear and passing as close to the FAD as possible without hooking it. Mahi mahi, barracuda, and sometimes large yellowfin are often the first fish to hit, and the first to go off the bite. When this happens, change over to lighter lines and smaller lures, trolling a little faster for the smaller tunas. It may ultimately be necessary to change to monofilament traces and to start chasing the tuna schools or following flocks of actively-feeding birds if the fish are not biting eagerly.

A consistent feature observed by FAD fishermen is that the majority of fish caught around FADs are taken on the up-current side. It is therefore worthwhile to devote more time to trolling in this area. Section 2I gives information on how to distinguish the up-current side of the FAD.

SUB-SURFACE TROLLING

Most of the materials normally used to make up a trolling line—nylon monofilament, wire, cable, hooks, swivels, and the bait itself—are denser than water and would normally sink. However, when trolling, the pressure of water against the line forces it to the surface, particularly when trolling at speed. Most baits and many types of lures normally ‘swim’ at or just below the sea surface, and may even leap or skip out of the water if trolled too fast.

Nevertheless, it is often desirable that the bait should be presented deeper in the water to be attractive to some types of fish. There are various ways of forcing the bait or lure to swim deeper:

- **Heavier line materials:** using wire instead of nylon monofilament for the mainline will lower the bait by an amount which depends on the line length and speed;
- **In-line sinkers:** a variety of heavy materials can be used, including lead weights manufactured for the purpose, lengths of iron bar, or chain.

An ideal in-line trolling sinker



- **Cannonballs:** heavy weights trolled at low speed and hauled up and down using a separate reel. The trolling line is attached to the cannonball using a breakaway which snaps or auto-releases when a fish is hooked.
- **Diving lures:** some artificial lures are themselves designed to dive. These usually incorporate a ‘mini-diving board’ or bib at the front of the lure, or have an angled nose or head section which forces them down. Lures of this type will usually dart from side to side very actively when being trolled.

Diving lures

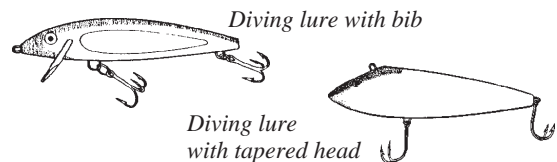

Diving boards

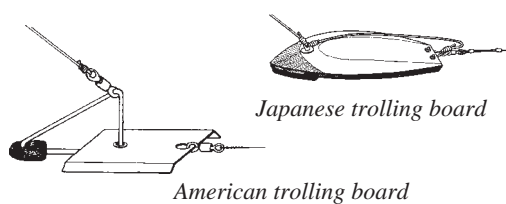

- **Diving boards** and similar devices are used as an alternative to sinkers to get the line down deeper. Most diving boards are essentially wooden, plastic or steel plates with a weighted nose which are attached between the mainline and the trace. A diving board planes like an underwater kite, diving deeper and carrying the lure along with it.

The trolling depth of the board depends on the size of the board, the speed of the boat, and the amount of line you pay out. Once the board reaches its maximum depth, it will (usually) stay there and remain steady provided that it is properly balanced. When a fish hooks up on the lure, the added weight on the line alters the board’s angle and causes it to trip and rise to the surface, dragging the fish along with it.

Action of a diving board

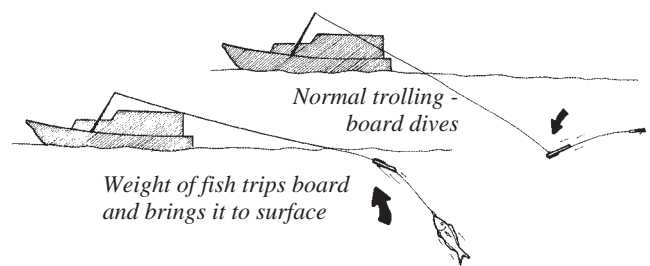

Although the most effective way to get a bait or lure down deep, a line with a diving board will often lose more fish than a weighted line, because it tends to go slack when the fish strikes and the board becomes unstable. A badly balanced board will swim from side to side and may gyrate when surfacing, causing line tangles.

SECTION 3F: CATCHING BAIT AROUND FADS

FADS AND BAIT

As well as attracting tuna and other large pelagic fish, FADs also attract many smaller fish—in fact this may be part of the reason why tunas gather around the FADs in the first place. These small fish are an ideal source of bait for vertical longlining and other tuna fishing activities. In fact, FADs are so useful for attracting bait that in some locations shallow-water FADs have been deployed close to shore for exactly this purpose.

FADs moored in shallow water may aggregate and hold schools of bait for long periods, both in areas where bait species are traditionally known to aggregate, and over open sandy bottoms with no history of bait presence. Shallow-water FAD systems have potential to provide Pacific Island fishermen with ready access to bait.

Bait-aggregating FADs set in shallow protected waters are inexpensive and simple to construct. Unlike deep-water FADs, large amounts of costly, heavy-duty mooring gear are not needed. Shallow-water FADs have been constructed from foam-filled plastic drums rigged in a rope harness and anchored with 100 kg concrete blocks. A few old tyres attached to the drum with short pieces of chain, or several coconut fronds function well as appendages.

In Hawaii, submerged or sub-surface FADs have been moored over open bottoms in shallow protected waters and have held schools of *opelu* (mackerel scad) for prolonged periods. These FADs were made from a standard 300 mm longline float, wire rope, and concrete blocks for anchors. The floats were rigged to lie about 10 metres below the surface, preventing interference and reducing wave-induced wear and tear, but still functioning to attract fish.

The same FADs used for vertical longlining can also supply bait. In the most favourable situation fishermen can motor to the FAD before sunrise, catch bait, and then set the longline in time to fish the early morning bite. However, that is not always possible. The species of bait occurring around the FAD are likely to vary throughout the year, so fishermen must coordinate bait-capture efforts with the presence of the different types.

Shallow-water FADs

Shallow-water FADs to attract bait can be made of simple, low-cost materials...

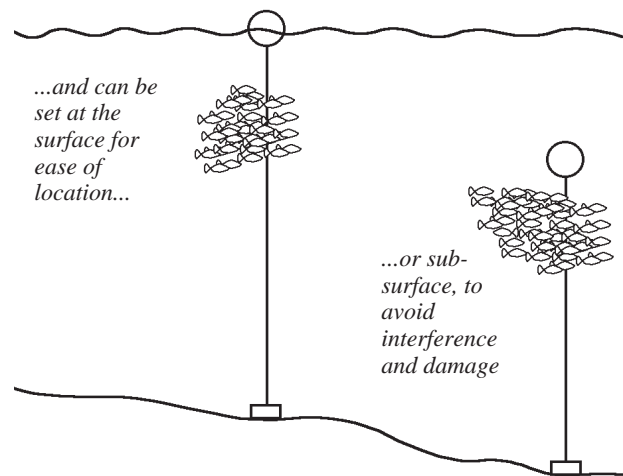

Sabiki bait jigging rig

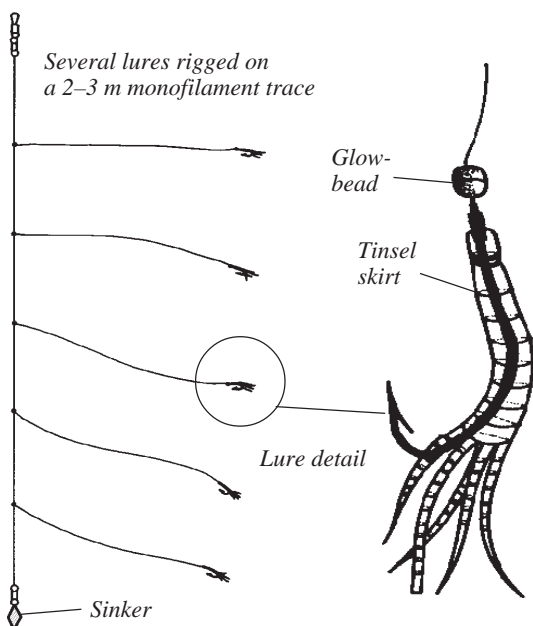

JIGGING

Although not every FAD will aggregate bait all the time, jigging around FADs is often productive, and does not require much gear. A sinker is tied to one end of a light monofilament line, and several jigs with short leaders are tied to the line just above the sinker. Jigs are made by tying various skirting material, such as small feathers, cotton thread, plastic strips or tinsel on to No. 5–8 hooks. However, inexpensive Japanese-made jig sets are widely available throughout the Pacific. One of the best is the sabiki rig, which is fitted with fluorescent glow-beads. In the Pacific region sabiki jigs generally cost between US\$ 2.00–4.00 each.

The hooks are lowered into the water and their depth adjusted to match that of the bait species. Jigs can either be handlined or fished with light spin casting gear. Handling the light line is easier with spinning gear, and the short rod adds flexibility and leverage for playing hooked fish.

During the height of the bigeye scad or mackerel scad season, jigging can produce up to 70 fish per hour. Over the longer term an average of 20 fish per hour could be expected during the season. Early morning and late afternoon are usually the best times for these species, as this is when they feed in surface waters. The fishing day can sometimes be extended by fishing deeper as the morning progresses.

Another good way to jig for bait is to fish at night using a light, especially on moonless nights. Plankton, which are a principal food of many baitfish species, are attracted to light. Bigeye scad and mackerel scad rise toward the surface at night to feed, and are drawn to the prey that has concentrated around the light. After the bait starts to appear, gradually dimming the light with a shade or a rheostat draws the bait into an aggregated group beneath the boat, where they can be held and fished for several hours.

Attracting bait using underwater lights

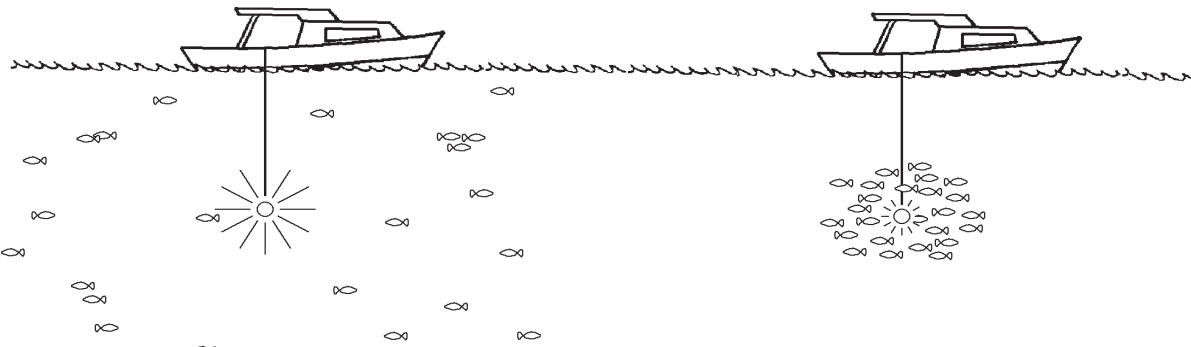

Bright lights at night will attract bait around the boat, where they can be fished using hook and line

Dimming the lights as the night proceeds will concentrate the bait, making them easier to catch

SUSPENDING FISH TRAPS FROM FADS

In Papua New Guinea, deploying shallow-water FADs made of traditional materials, with a trap underneath them, is a standard way to capture small pelagic fish in some areas. On several country assignments, SPC Master-fishermen have adapted this principle by suspending traps made from more modern materials under oceanic FADs in order to catch bait.

Light rectangular wooden frames measuring about 2 m x 1 m x 1 m were built and covered with chicken wire mesh. A door and latch for emptying the trap were made in the upper surface, and chicken wire cone entrances were fixed at both ends of the trap. Weights were wired to the wooden frame, inside and along the bottom, to keep the trap under water. A rope bridle was rigged to the four corners of the trap's upper surface, and the trap then suspended about 4 m below the FAD. Traps were never baited, and the entrances were not built in a way that would prevent fish from escaping.

A simple wooden-framed wire-mesh bait trap

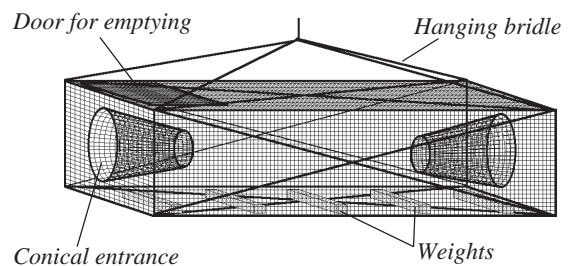

The traps generally worked well when suspended from FADs known to regularly aggregate baitfishes. A typical daily catch in one location was 30–60 pieces of bigeye scad or mackerel scad, with the best catch being 140 pieces.

Traps can also have other, sometimes unpredicted, benefits. In at least one location a trap suspended below a FAD to catch bait caught triggerfish instead. These fish are of no use as bait, but they had become a serious nuisance around the FAD due to their habit of picking bait from the fishermen's hooks. Their presence made it impossible to carry out vertical longlining near the FAD. This suggests a role for traps in removal of undesirable or nuisance fish from vertical longlining areas.

Unfortunately traps may be limited in their usefulness due to problems of ownership. If one individual suspends a trap from a FAD it is almost certain to arouse jealousy in other users of the FAD. The result is likely to be that the catch will be stolen or the trap vandalised. Unless some arrangement can be made with other fishermen to share in the cost and operation of the trap and its catches, the prospects for trapping bait under a FAD may be limited.

SECTION 3G: OTHER POSSIBLE FAD BAIT-FISHING METHODS

Hawaiian-style hoop-net fishing

Hoop-net fishing is a Hawaiian technique of catching mackerel scad by using chum to attract them and manoeuvre them over and into a hoop-shaped net. The fishing method has been used in Hawaii for centuries, but the use of modern materials now results in gear which is a lot easier both to construct and to operate. The fishing method has been tried experimentally in a few Pacific locations, with promising results, but so far has not been adopted, perhaps partly because the initial investment in gear is quite costly.

The fishing method uses a long cone-shaped net whose mouth is held open using fibreglass poles. The net is hauled vertically in the water once fish are over or in it. Despite its bulk when assembled, the net is compact when in storage. During fishing the net is not assembled until after it has been put in the water, so it can be operated from small boats or even canoes.

Fishing relies on the use of a bait bag which is repeatedly filled with chum and thrown out, releasing the bait in a trail which lures the fish into the mouth of the net. Another essential item is a glass-bottom vision box, which is used to check for the presence of fish and monitor their movements. Once the fish are seen to be entering the net, it is quickly hauled to the surface.

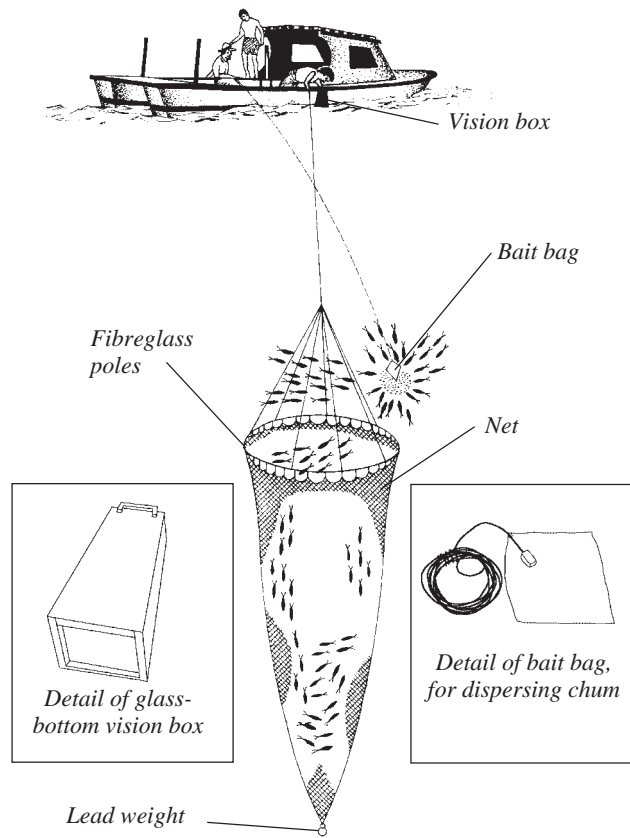

A full description of this fishing method can be found in the FAO report “*Hawaiian-Style Decapterus Fishing Trials in Niue*” by Bob Gillett.

Squid fishing

Squid can often be captured at night from a boat tied up to a FAD and is one of the best baits for tuna fishing. They are usually most abundant during the cold season, and can be caught in the daytime or at night by attracting them to the boat with lights. The best fishing method is to use a rod or handline to work Japanese squid lures, which are of two principal types:

- brightly-coloured balsa-wood or plastic models shaped and decorated with eyes and whiskers to look like a swimming prawn.
- a metal stem which can be baited using a small whole fish or strip-bait.

In both cases the normal fishing method is to cast and retrieve the lures so that they are in constant motion.

Another way to catch squid is by gaffing, a method best practised from a boat fishing at night with lights. Squid are lured to the boat by tossing out a whole scad hooked through the head with a fish hook and retrieving it in the same manner as the squid lure. Once the bait draws them within reach, the squid are gaffed. The gaff is similar to the squid jig, but with slightly longer prongs (5–6 cm) and a 1 m long bamboo handle.

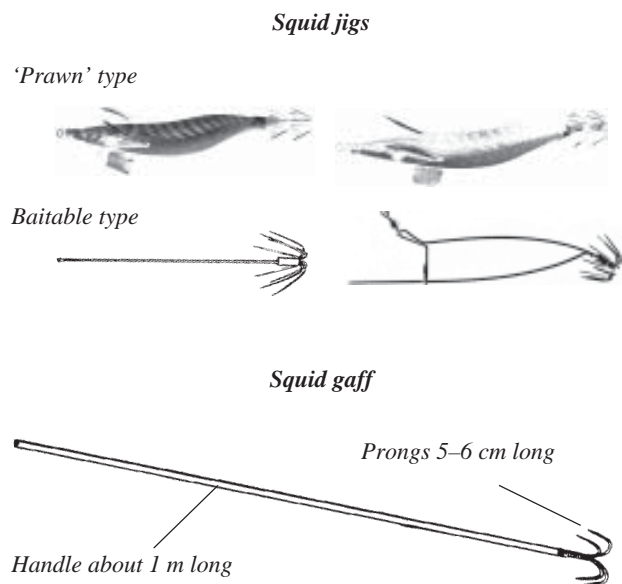

SECTION 3G: NON-FAD BAIT-FISHING METHODS

As well as the FAD-associated bait-fishing techniques, there are a number of other bait-fishing methods which have no particular connection with FADs but which are useful for vertical longline fishermen to know about.

Hook and line

Bigeye scad and mackerel scad make daily migrations, moving from offshore to nearshore waters and shoal over sandy bottoms. Fishermen standing in the shallow waters can catch them by casting with bamboo poles fitted with a length of light monofilament just shorter than the pole and a small single or double hook rigged with a white feather or twist of cotton. The fish are attracted by chumming, using coconut flesh which the fishermen chew up and spit out. This technique can also be carried out from a canoe or small boat.

Gillnetting

Bigeye scad and mackerel scad tend to feed near the sea floor and can often be caught at night using bottom-set gillnets.

Fishing normally takes place at night on sandy bottoms in reef passages or channels, with nets being set or hauled from a dinghy by 2 or 3 people.

Nets are set at night and are soaked for 3–4 hours before hauling.

Gillnet for bigeye and mackerel scads

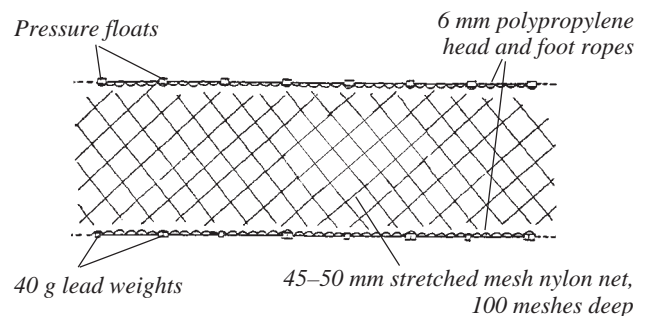

Ring netting

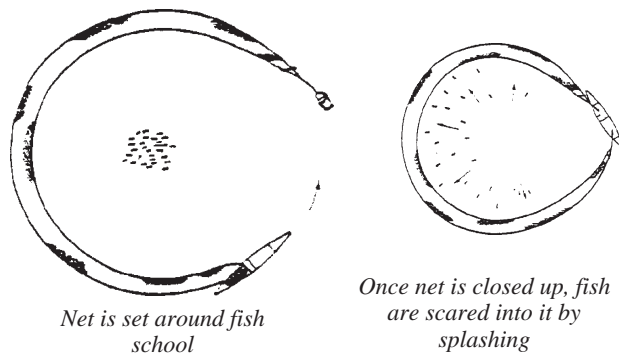

Ring-netting

A ring net is a floating small-meshed gillnet used to capture surface-schooling baitfish such as garfish and mullet. The net is set around a school of fish from a small paddle-powered boat which is quiet enough not to scare the fish away.

Fish may need to be chummed up using pieces of buttered bread (the butter also smooths out ripples on the water surface, making the fish easier to see). As hauling takes place it may be necessary to scare the fish into the net by splashing.

Scoop Netting

This method is mainly used to catch flying fish, but it also works for garfish or halfbeaks. Scoop netting requires a small, very manoeuvrable powerboat, a light source to attract and blind the fish, and a long-handled net to scoop fish from the water. Lights are usually either a pressure lantern mounted over the bow, or a helmet mounted battery-powered headlight. Two crew are usually needed, one to run the boat and one to handle the net, but in French Polynesia and Cook Islands there are specialised flying-fish boats in which a solo fisherman can scoop fish over the bow of the boat while simultaneously operating the steering control.

Cast net

Cast nets are one of the most popular fishing gears in the Pacific Islands.

They are small (3–4 m in diameter) circular throwing nets which are used to catch a variety of inshore species including herrings, sardines, anchovies and hardyheads, all of which are good bait species.



CONCLUDING REMARKS

Vertical longline fishing around FADs can be a productive and potentially lucrative activity. It allows fishermen to target abundant resources of coastal tunas using small boats and simple, relatively inexpensive gear. Where cash markets for fish are well-developed, good-quality fresh tuna can command premium prices. Provided they look after their catch properly, fishermen carrying out vertical longlining around FADs can target this market and make much greater profits than they could from many other styles of fishing.

SPC is actively promoting FAD-based vertical longlining as a means of helping Pacific Island countries draw greater benefits from their tuna resources, improve the quality of food available to the population, and divert fishing effort away from reef and lagoon stocks that are often overfished. As well as this handbook, SPC has produced other manuals on various aspects of fishing and FADs. The 3-volume SPC FAD Manual provides information on planning FAD programmes, designing FADs, and FAD deployment and maintenance, while handbooks on trolling and (shortly) horizontal longlining and deep-bottom fishing describe these fishing techniques in detail. In addition SPC runs short courses in vertical longlining, tuna handling and marketing, FAD deployment and maintenance, management of small fishing businesses, and other relevant subjects. Government Fisheries Departments or their equivalents in each Pacific Island country should be fully informed about the range of SPC activities in this field, and can help interested fishermen find out more, or get in touch with SPC.

We hope this manual has been useful to any readers who feel inclined to try vertical longlining. For further information, advice, or technical assistance, contact your local Fisheries Department, or write directly to SPC at the address below.

*Secretariat of the Pacific Community
Coastal Fisheries Programme - Capture Section
B. P. D5, 98848 Noumea Cedex
New Caledonia*

Phone: +687 262000

Fax: +687 263818

E-mail: Capture@spc.org.nc

Web site: <http://www.spc.org.nc>